



Long Shutdown 2 2018-2021 Week by Week Schedule

Many thanks for your input

Working days 2018-19

December 2018
1 days included

Mon	Tue	Wed	Thu	Fri	Sat	Sun
					1	2
3	4	5	6	7	8	9
10	11	12	13	14	15	16
17	18	19	20	21	22	23
24	25	26	27	28	29	30
31						

January 2019
22 days included

Mon	Tue	Wed	Thu	Fri	Sat	Sun
	1	2	3	4	5	6
7	8	9	10	11	12	13
14	15	16	17	18	19	20
21	22	23	24	25	26	27
28	29	30	31			

February 2019
20 days included

Mon	Tue	Wed	Thu	Fri	Sat	Sun
				1	2	3
4	5	6	7	8	9	10
11	12	13	14	15	16	17
18	19	20	21	22	23	24
25	26	27	28			

March 2019
21 days included

Mon	Tue	Wed	Thu	Fri	Sat	Sun
				1	2	3
4	5	6	7	8	9	10
11	12	13	14	15	16	17
18	19	20	21	22	23	24
25	26	27	28	29	30	31

April 2019
20 days included

Mon	Tue	Wed	Thu	Fri	Sat	Sun
1	2	3	4	5	6	7
8	9	10	11	12	13	14
15	16	17	18	19	20	21
22	23	24	25	26	27	28
29	30					

May 2019
22 days included

Mon	Tue	Wed	Thu	Fri	Sat	Sun
		1	2	3	4	5
6	7	8	9	10	11	12
13	14	15	16	17	18	19
20	21	22	23	24	25	26
27	28	29	30	31		

June 2019
19 days included

Mon	Tue	Wed	Thu	Fri	Sat	Sun
					1	2
3	4	5	6	7	8	9
10	11	12	13	14	15	16
17	18	19	20	21	22	23
24	25	26	27	28	29	30

July 2019
23 days included

Mon	Tue	Wed	Thu	Fri	Sat	Sun
1	2	3	4	5	6	7
8	9	10	11	12	13	14
15	16	17	18	19	20	21
22	23	24	25	26	27	28
29	30	31				

August 2019
21 days included

Mon	Tue	Wed	Thu	Fri	Sat	Sun
			1	2	3	4
5	6	7	8	9	10	11
12	13	14	15	16	17	18
19	20	21	22	23	24	25
26	27	28	29	30	31	

September 2019
20 days included

Mon	Tue	Wed	Thu	Fri	Sat	Sun
						1
2	3	4	5	6	7	8
9	10	11	12	13	14	15
16	17	18	19	20	21	22
23	24	25	26	27	28	29
30						

October 2019
23 days included

Mon	Tue	Wed	Thu	Fri	Sat	Sun
	1	2	3	4	5	6
7	8	9	10	11	12	13
14	15	16	17	18	19	20
21	22	23	24	25	26	27
28	29	30	31			

November 2019
21 days included

Mon	Tue	Wed	Thu	Fri	Sat	Sun
				1	2	3
4	5	6	7	8	9	10
11	12	13	14	15	16	17
18	19	20	21	22	23	24
25	26	27	28	29	30	

December 2019
1 days included

Mon	Tue	Wed	Thu	Fri	Sat	Sun
						1
2	3	4	5	6	7	8
9	10	11	12	13	14	15
16	17	18	19	20	21	22
23	24	25	26	27	28	29
30	31					

11/06/18

cms-tc-planning@cern.ch

Working Days 2020

January 2020
2 days included

Mon	Tue	Wed	Thu	Fri	Sat	Sun
		1	2	3	4	5
6	7	8	9	10	11	12
13	14	15	16	17	18	19
20	21	22	23	24	25	26
27	28	29	30	31		

February 2020
20 days included

Mon	Tue	Wed	Thu	Fri	Sat	Sun
					1	2
3	4	5	6	7	8	9
10	11	12	13	14	15	16
17	18	19	20	21	22	23
24	25	26	27	28	29	

March 2020
22 days included

Mon	Tue	Wed	Thu	Fri	Sat	Sun
						1
2	3	4	5	6	7	8
9	10	11	12	13	14	15
16	17	18	19	20	21	22
23	24	25	26	27	28	29
30	31					

April 2020
20 days included

Mon	Tue	Wed	Thu	Fri	Sat	Sun
		1	2	3	4	5
6	7	8	9	10	11	12
13	14	15	16	17	18	19
20	21	22	23	24	25	26
27	28	29	30			

May 2020
20 days included

Mon	Tue	Wed	Thu	Fri	Sat	Sun
				1	2	3
4	5	6	7	8	9	10
11	12	13	14	15	16	17
18	19	20	21	22	23	24
25	26	27	28	29	30	31

June 2020
21 days included

Mon	Tue	Wed	Thu	Fri	Sat	Sun
1	2	3	4	5	6	7
8	9	10	11	12	13	14
15	16	17	18	19	20	21
22	23	24	25	26	27	28
29	30					

July 2020
23 days included

Mon	Tue	Wed	Thu	Fri	Sat	Sun
		1	2	3	4	5
6	7	8	9	10	11	12
13	14	15	16	17	18	19
20	21	22	23	24	25	26
27	28	29	30	31		

August 2020
21 days included

Mon	Tue	Wed	Thu	Fri	Sat	Sun
					1	2
3	4	5	6	7	8	9
10	11	12	13	14	15	16
17	18	19	20	21	22	23
24	25	26	27	28	29	30
31						

September 2020
21 days included

Mon	Tue	Wed	Thu	Fri	Sat	Sun
	1	2	3	4	5	6
7	8	9	10	11	12	13
14	15	16	17	18	19	20
21	22	23	24	25	26	27
28	29	30				

October 2020
22 days included

Mon	Tue	Wed	Thu	Fri	Sat	Sun
			1	2	3	4
5	6	7	8	9	10	11
12	13	14	15	16	17	18
19	20	21	22	23	24	25
26	27	28	29	30	31	

November 2020
21 days included

Mon	Tue	Wed	Thu	Fri	Sat	Sun
						1
2	3	4	5	6	7	8
9	10	11	12	13	14	15
16	17	18	19	20	21	22
23	24	25	26	27	28	29
30						

December 2020
1 days included

Mon	Tue	Wed	Thu	Fri	Sat	Sun
	1	2	3	4	5	6
7	8	9	10	11	12	13
14	15	16	17	18	19	20
21	22	23	24	25	26	27
28	29	30	31			

Working Days 2021

January 2021						
20 days included						
Mon	Tue	Wed	Thu	Fri	Sat	Sun
				1	2	3
4	5	6	7	8	9	10
11	12	13	14	15	16	17
18	19	20	21	22	23	24
25	26	27	28	29	30	31

February 2021						
20 days included						
Mon	Tue	Wed	Thu	Fri	Sat	Sun
1	2	3	4	5	6	7
8	9	10	11	12	13	14
15	16	17	18	19	20	21
22	23	24	25	26	27	28

Design Method

→ Assumptions

- 5 working days/week = 561 days
- Bank holidays / Lab closure included
- Shift work possible when required
- Current levels of expertise maintained
- Using proven existing tooling

Objectives not included in this draft

- CMS Safety activities
- ECAL activities
- Rotating shielding...
- UXC55 X1 floor survey
- HF grease pad maintenance
- HVAC software upgrade

Key objectives

Infrastructure:

- Modify SCX5 Ctrl room by beginning of LS2 – CMS/SMB
- Build SXA5 – CMS/SMB
- Add UPS for the DAQ computer farm – EN-EL
- Move SCX5 UPS out of ctrl room to dedicated UPS building – EN-EL ???
- Add 1.5 MW cooling capacity to the chilled water system –EN-CV
 - Check with Paola
- Refurbish SUX5 control infrastructure for chilled/mixed water production – EN-CV
- Refurbish USC55 control infrastructure for all water distribution system – EN-CV
- Consolidate instrument air infrastructure in SH5 – EN-CV
- Refurbish underground ventilation control system– EN-CV

Key objectives

Work on End Caps:

- Install new beam pipe
- Install GE1/1 (including pipes + cables – remove “slice test” detector installed in 2016)
- Refurbish ME2/1, ME3/1, ME4/1 – trigger latency boards
- Service installation for GE2/1, RE4/1, RE3/1
- YE+/-1 new cable chain installation

Key objectives

Work on Barrels:

- Fix RPC leaks in barrel region
- MB4 Shielding
- HB - Carry out phase1 upgrade of Front-End electronics, i.e. replacement of HPD-→SiPMs
- Standard DT and RPC maintenance
 - Inner wheels not accessed since LS1
- DT Phase 2 minicrate slice test

Key objectives

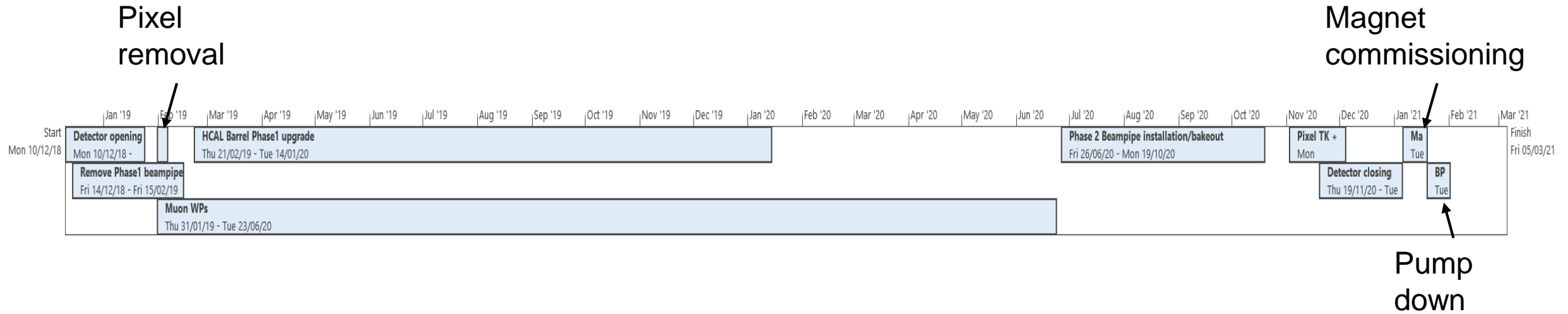



Crane

Cryo.	■	EL power	■	Water cool.	■	Database	■
IT	■	Magnet	■	C6F14	■	Gas	■
SL. 0	GEM	ECAL	ZEC	DT+ RB	Survey	TE-VSC	GS Dept
CP. 0	TOTEM	CMX	CSC RE	TK PIX	HCAL	EN Dept	RP

PX56 Plug CLOSED
TX54 Plug CLOSED

2018
December - Week 50

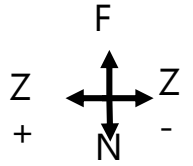

- A. Open PX56 Plug
- B. Open TX54 Plug

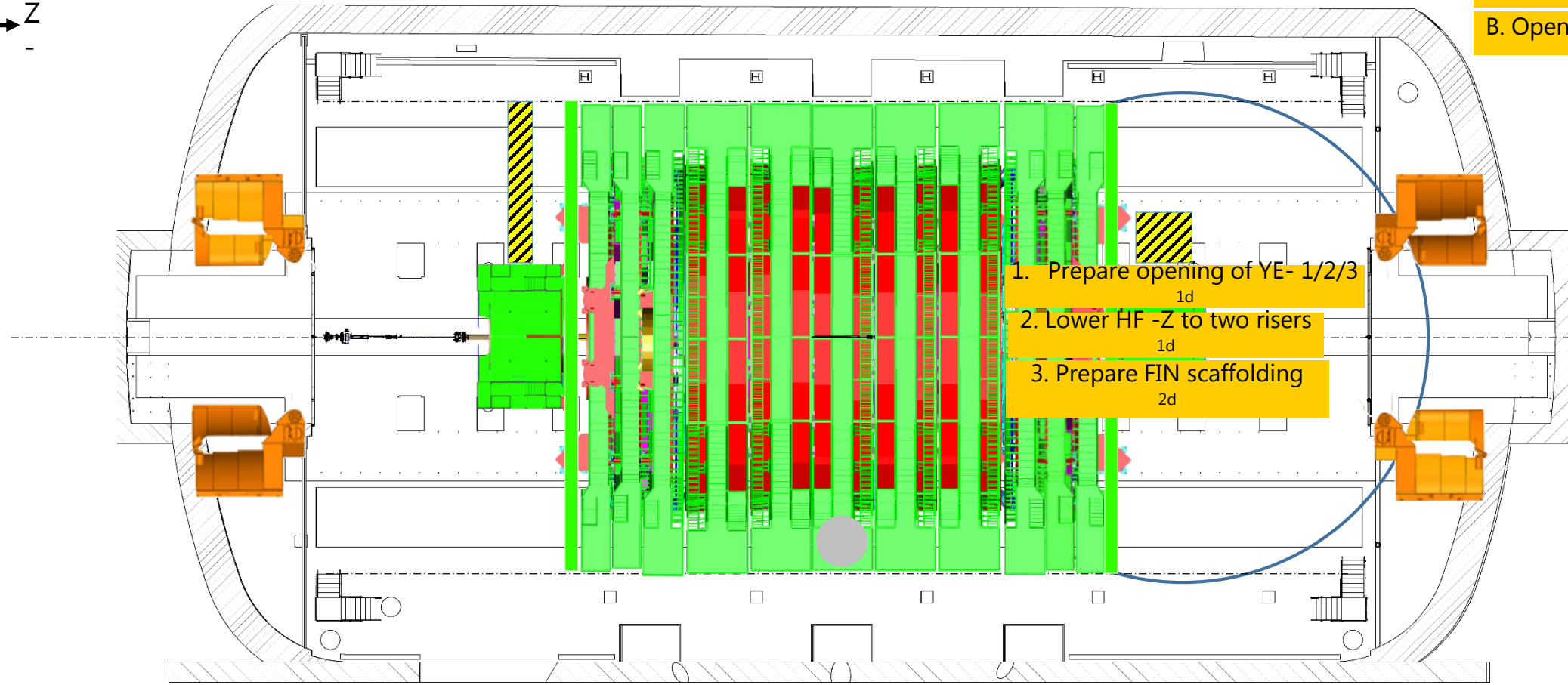

1. Prepare opening of YE- 1/2/3
1d
2. Lower HF -Z to two risers
1d
3. Prepare FIN scaffolding
2d

5m



Cryo.	█	EL power	█	Water cool.	█	Database	█
IT	█	Magnet	█	C6F14	█	Gas	█
SL. 0	GEM	ECAL	ZEC	DT+ RB	Survey	TE-VSC	GS Dept
CP. 0	TOTEM	CMX	CSC RE	TK PIX	HCAL	EN Dept	RP

PX56 Plug CLOSED	2018
TX54 Plug CLOSED	December - Week 51

Crane

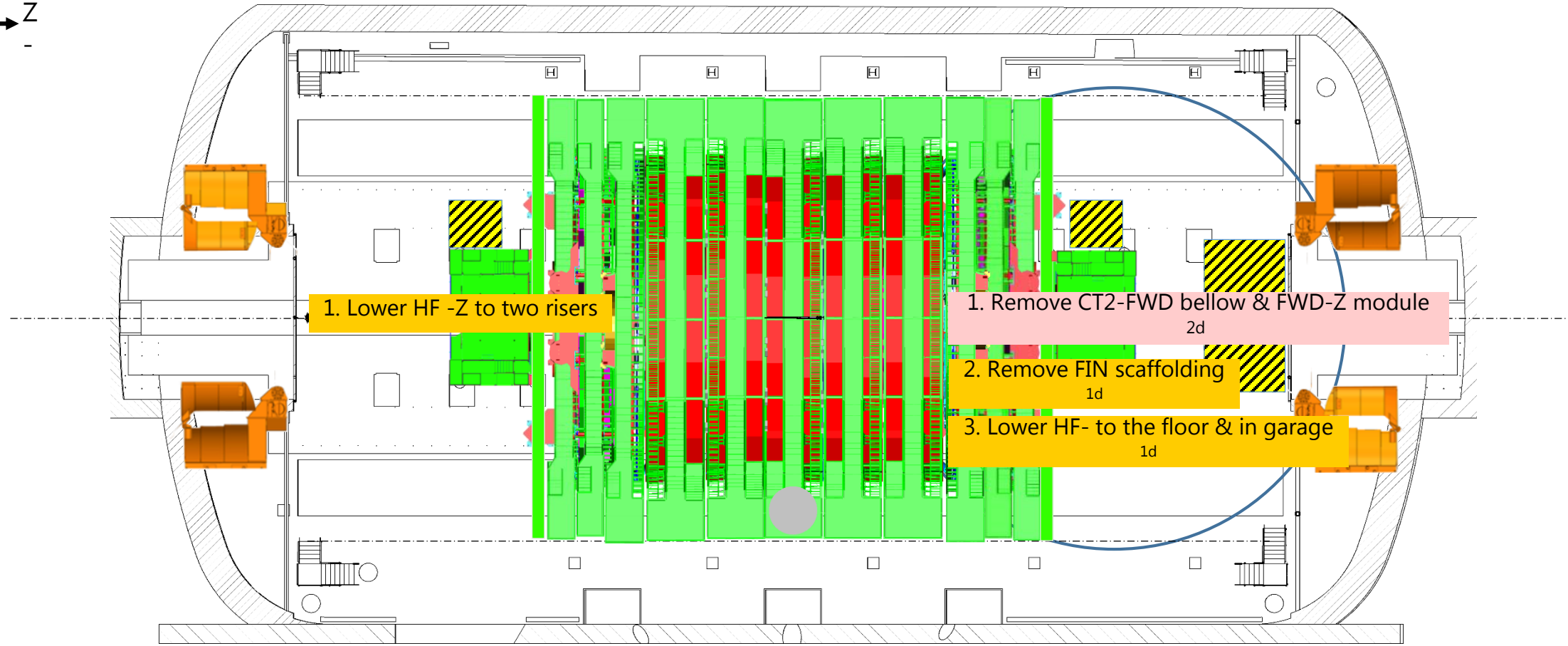
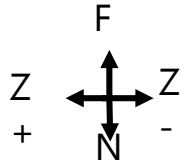

1. Lower HF -Z to two risers

1. Remove CT2-FWD bellow & FWD-Z module

2d

2. Remove FIN scaffolding

1d

3. Lower HF- to the floor & in garage

1d

5m



Crane

Cryo.		EL power		Water cool.		Database	
IT		Magnet		C6F14		Gas	
SL. 0							
CP. 0							

PX56 Plug CLOSED
TX54 Plug CLOSED

2018
December - Week 52

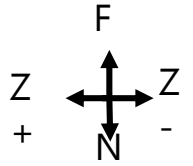

End of Year Lab Closure

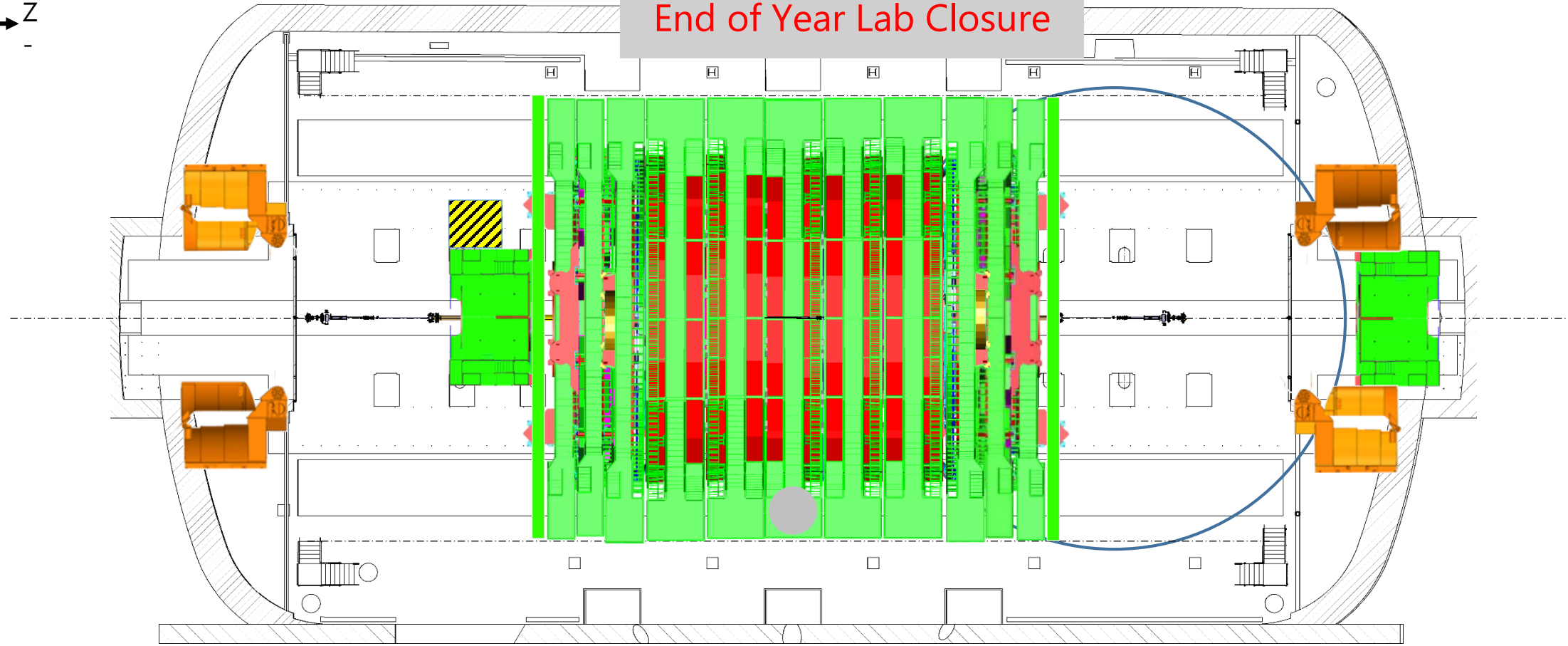

5m



Crane

Cryo.		EL power		Water cool.		Database	
IT		Magnet		C6F14		Gas	
SL. 0							
CP. 0							

PX56 Plug
CLOSED

TX54 Plug
CLOSED

2019

January - Week 1

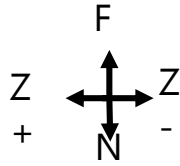

End of Year Lab Closure

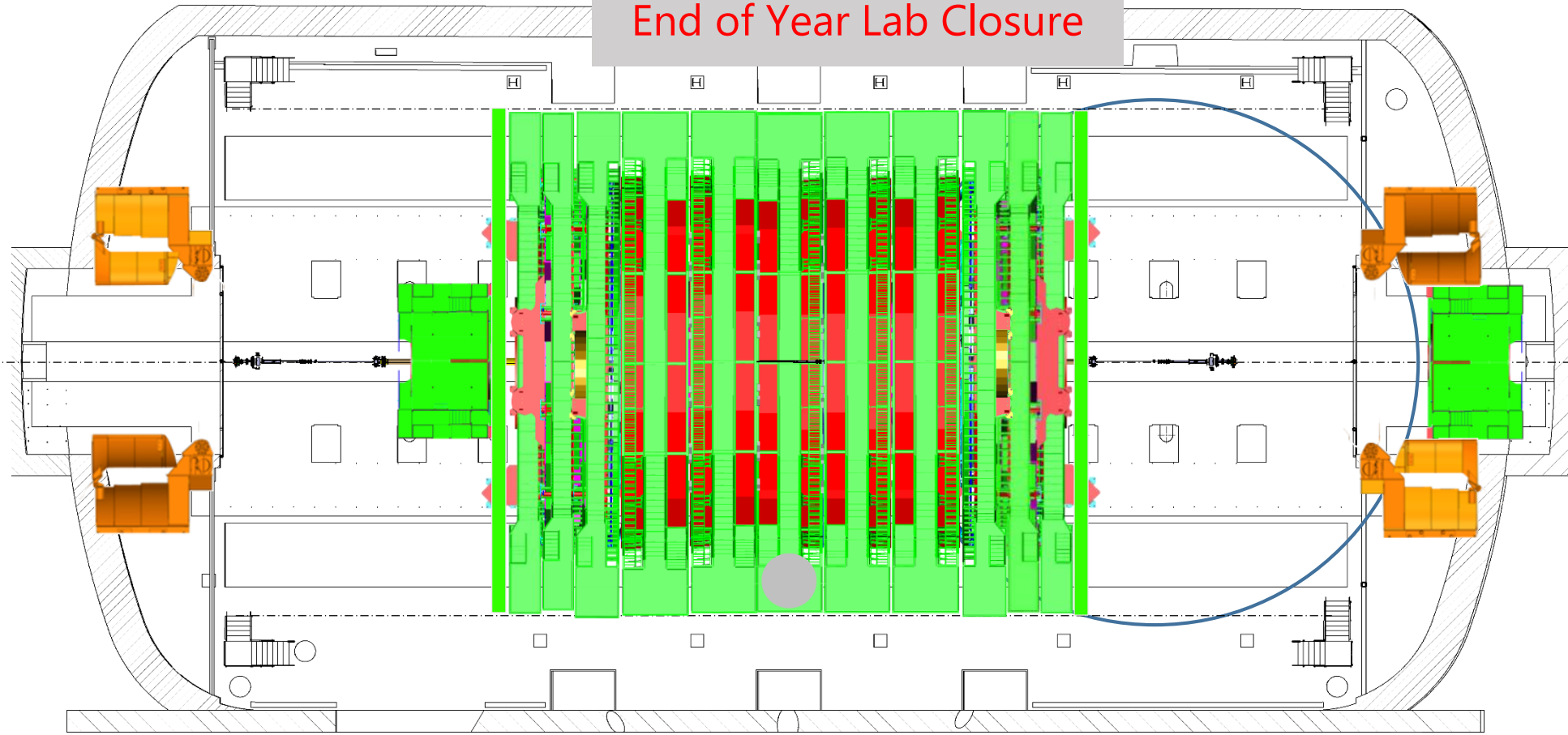

5m



Crane

Cryo.	█	EL power	█	Water cool.	█	Database	█								
IT	█	Magnet	█	C6F14	█	Gas	█								
SL.	0	GEM	█	ECAL	█	ZEC	█	DT+ RB	█	Survey	█	TE-VSC	█	GS Dept	█
CP.	0	TOTEM	█	CMX	█	CSC RE	█	TK PIX	█	HCAL	█	EN Dept	█	RP	█

PX56 Plug	CLOSED
TX54 Plug	CLOSED

2019

January - Week 2

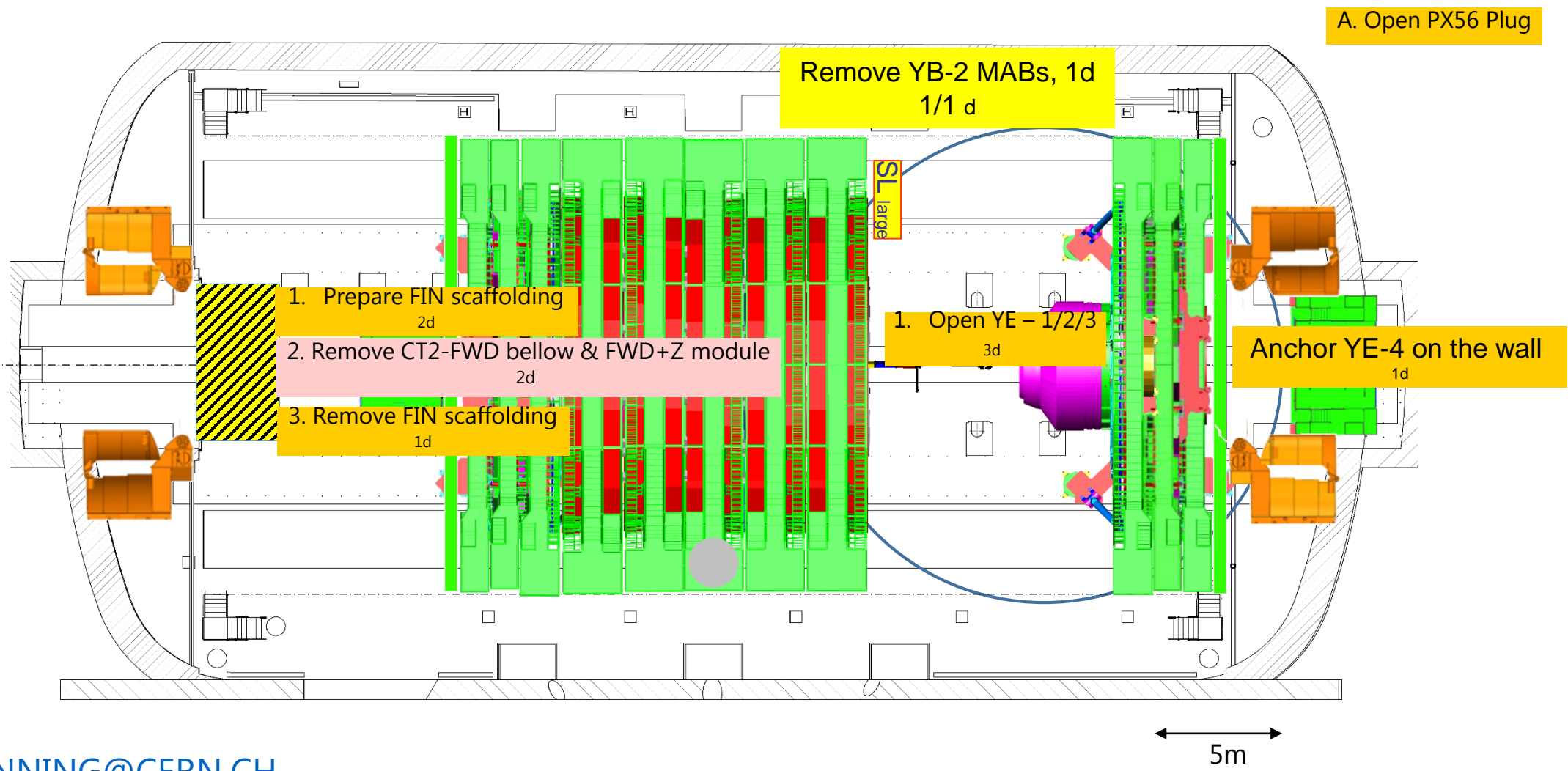
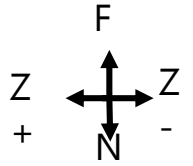



Crane

Cryo.	<input type="checkbox"/>	EL power	<input type="checkbox"/>	Water cool.	<input type="checkbox"/>	Database	<input type="checkbox"/>	
IT	<input type="checkbox"/>	Magnet	<input type="checkbox"/>	C6F14	<input type="checkbox"/>	Gas	<input type="checkbox"/>	
SL.	0	GEM	ECAL	ZEC	DT+ RB	Survey	TE-VSC	GS Dept
CP.	0	TOTEM	CMX	CSC RE	TK PIX	HCAL	EN Dept	RP

PX56 Plug
CLOSED

TX54 Plug
CLOSED

2019

January - Week 3

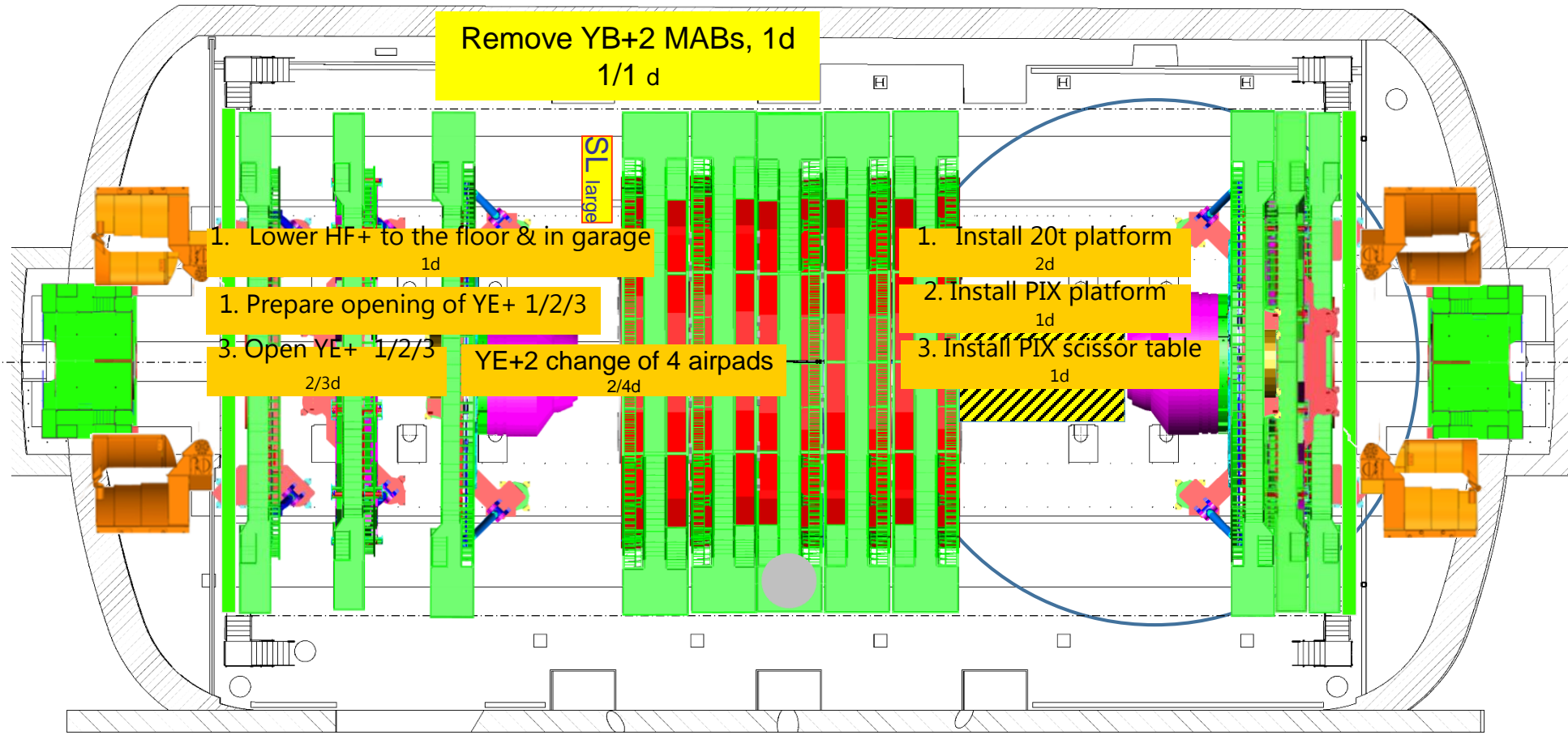
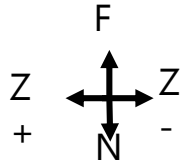

5m



Crane

Cryo.	<input type="checkbox"/>	EL power	<input type="checkbox"/>	Water cool.	<input type="checkbox"/>	Database	<input type="checkbox"/>	
IT	<input type="checkbox"/>	Magnet	<input type="checkbox"/>	C6F14	<input type="checkbox"/>	Gas	<input type="checkbox"/>	
SL.	0	GEM	ECAL	ZEC	DT+ RB	Survey	TE-VSC	GS Dept
CP.	0	TOTEM	CMX	CSC RE	TK PIX	HCAL	EN Dept	RP

PX56 Plug CLOSED
TX54 Plug CLOSED

2019
January - Week 4

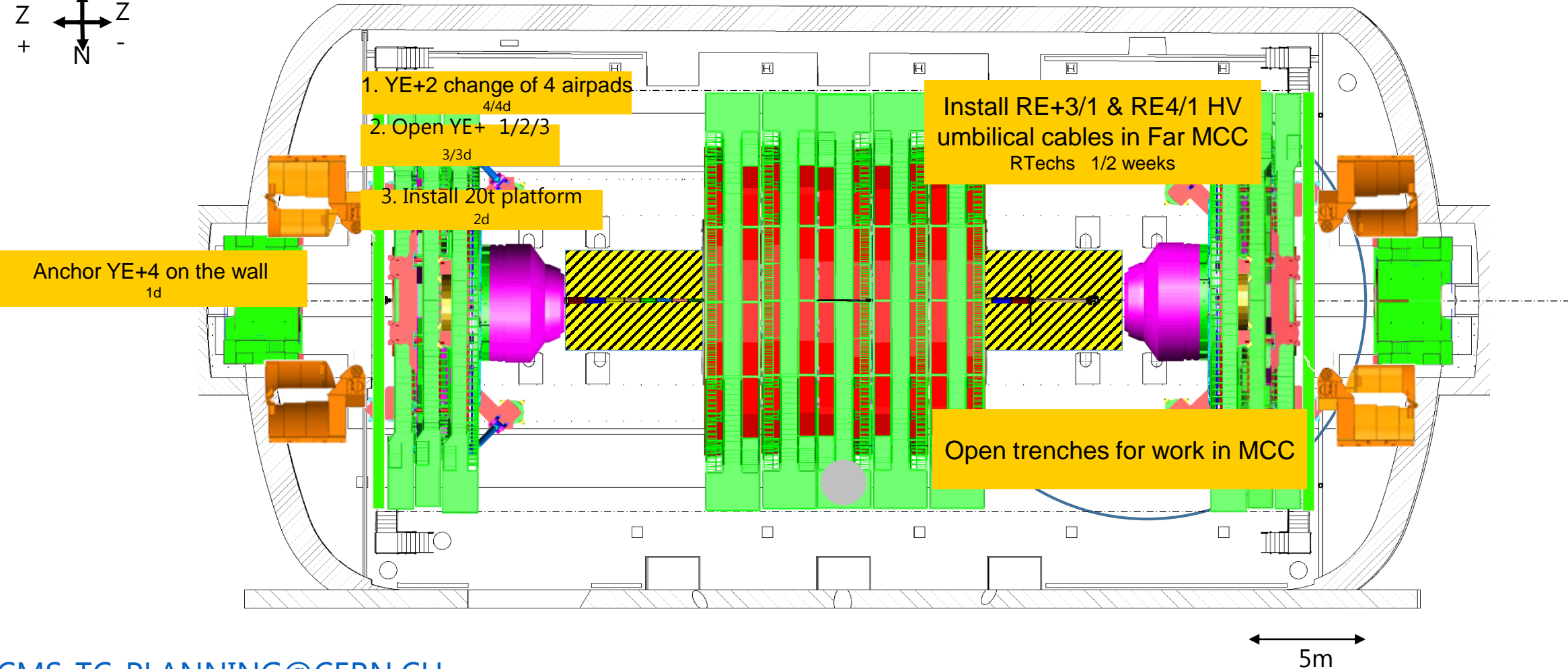



Crane

Cryo.	<input type="checkbox"/>	EL power	<input type="checkbox"/>	Water cool.	<input type="checkbox"/>	Database	<input type="checkbox"/>	
IT	<input type="checkbox"/>	Magnet	<input type="checkbox"/>	C6F14	<input type="checkbox"/>	Gas	<input type="checkbox"/>	
SL.	0	GEM	ECAL	ZEC	DT+ RB	Survey	TE-VSC	GS Dept
CP.	0	TOTEM	CMX	CSC RE	TK PIX	HCAL	EN Dept	RP

PX56 Plug CLOSED
TX54 Plug CLOSED

2019
January - Week 5

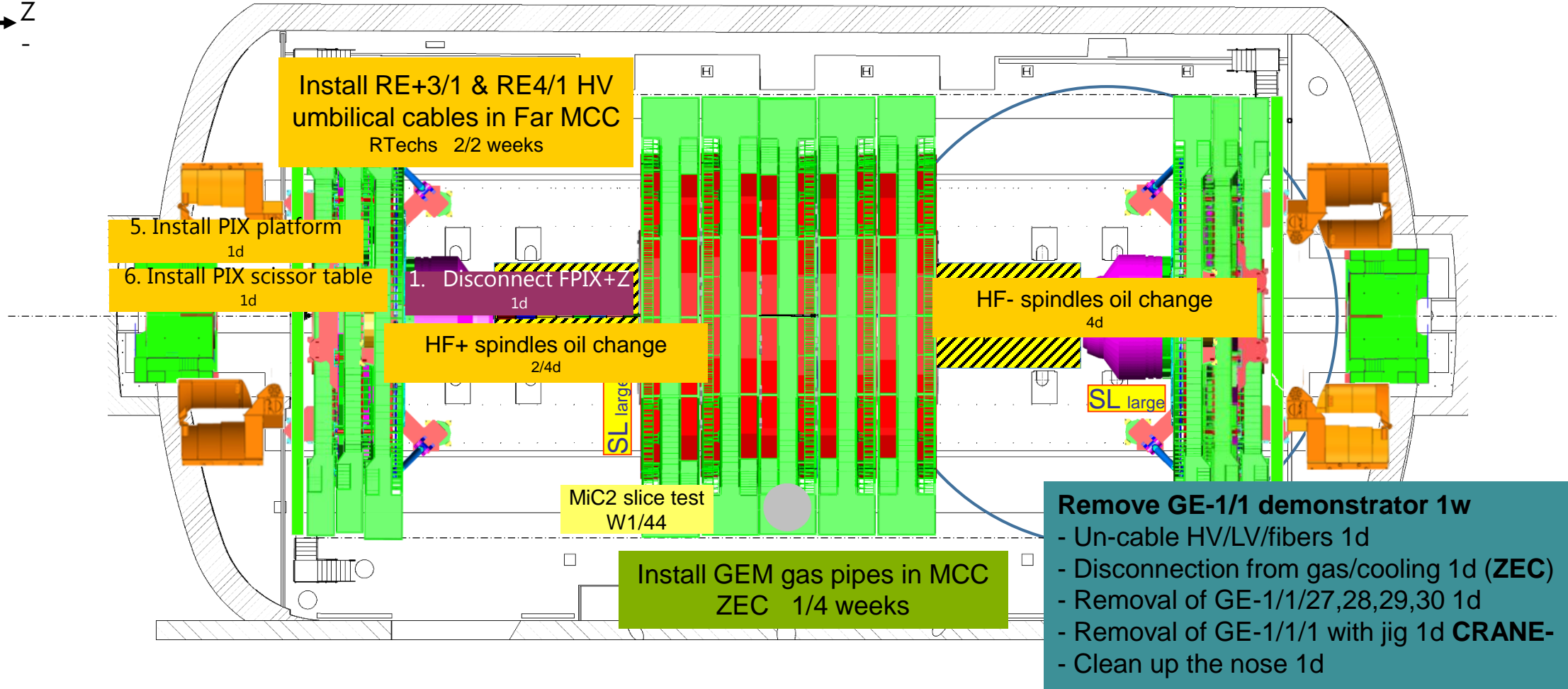
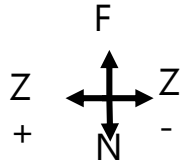

- Remove GE-1/1 demonstrator 1w**
- Un-cable HV/LV/fibers 1d
- Disconnection from gas/cooling 1d (**ZEC**)
- Removal of GE-1/1/27,28,29,30 1d
- Removal of GE-1/1/1 with jig 1d **CRANE-**
- Clean up the nose 1d



Cryo.	█	EL power	█	Water cool.	█	Database	█
IT	█	Magnet	█	C6F14	█	Gas	█
SL. 0	GEM	ECAL	ZEC	DT+ RB	Survey	TE-VSC	GS Dept
CP. 0	TOTEM	CMX	CSC RE	TK PIX	HCAL	EN Dept	RP

PX56 Plug
CLOSED

TX54 Plug
CLOSED

2019

February - Week 6

Crane

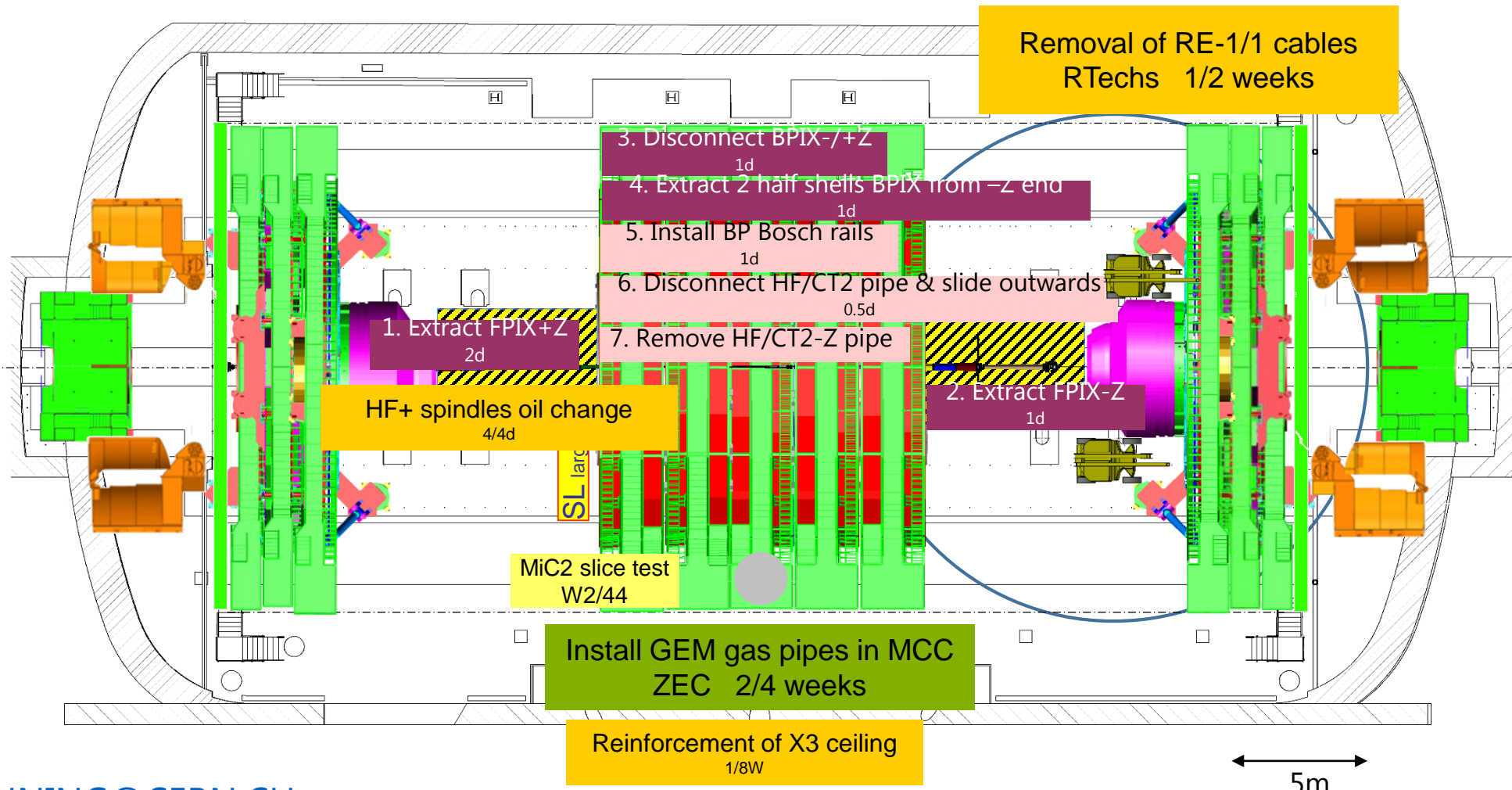
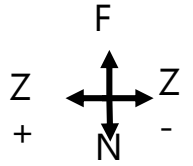

5m



Crane

Cryo.	█	EL power	█	Water cool.	█	Database	█
IT	█	Magnet	█	C6F14	█	Gas	█
SL. 0	GEM	ECAL	ZEC	DT+ RB	Survey	TE-VSC	GS Dept
CP. 0	TOTEM	CMX	CSC RE	TK PIX	HCAL	EN Dept	RP

PX56 Plug CLOSED
TX54 Plug CLOSED

2019
February - Week 7

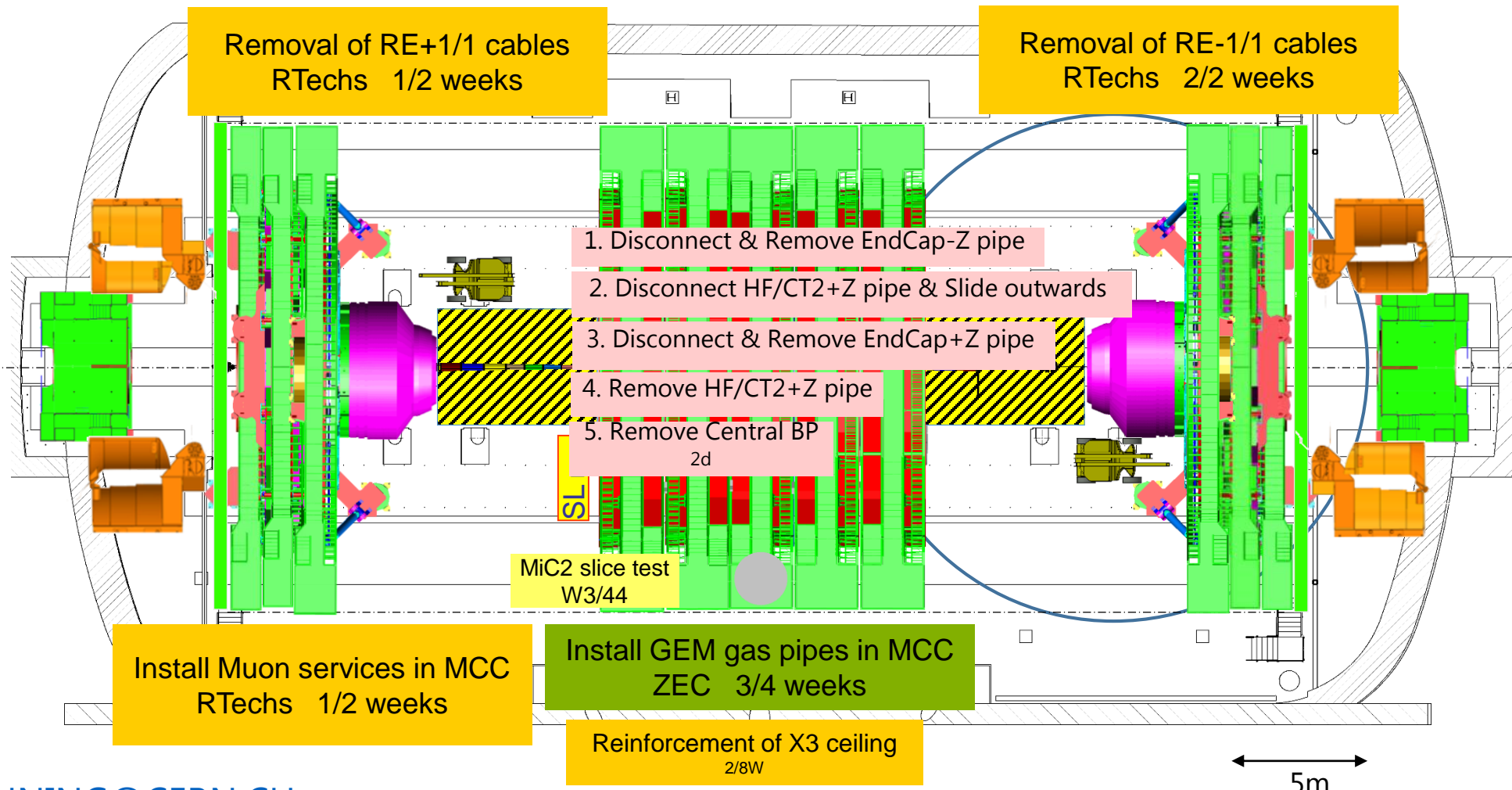
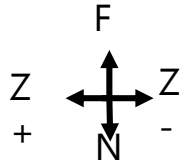



Crane

Cryo.	█	EL power	█	Water cool.	█	Database	█								
IT	█	Magnet	█	C6F14	█	Gas	█								
SL.	0	GEM	█	ECAL	█	ZEC	█	DT+ RB	█	Survey	█	TE-VSC	█	GS Dept	█
CP.	0	TOTEM	█	CMX	█	CSC RE	█	TK PIX	█	HCAL	█	EN Dept	█	RP	█

PX56 Plug
CLOSED

TX54 Plug
CLOSED

2019

February - Week 8

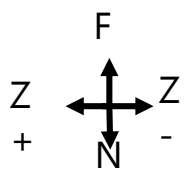

School Holiday GE+FR

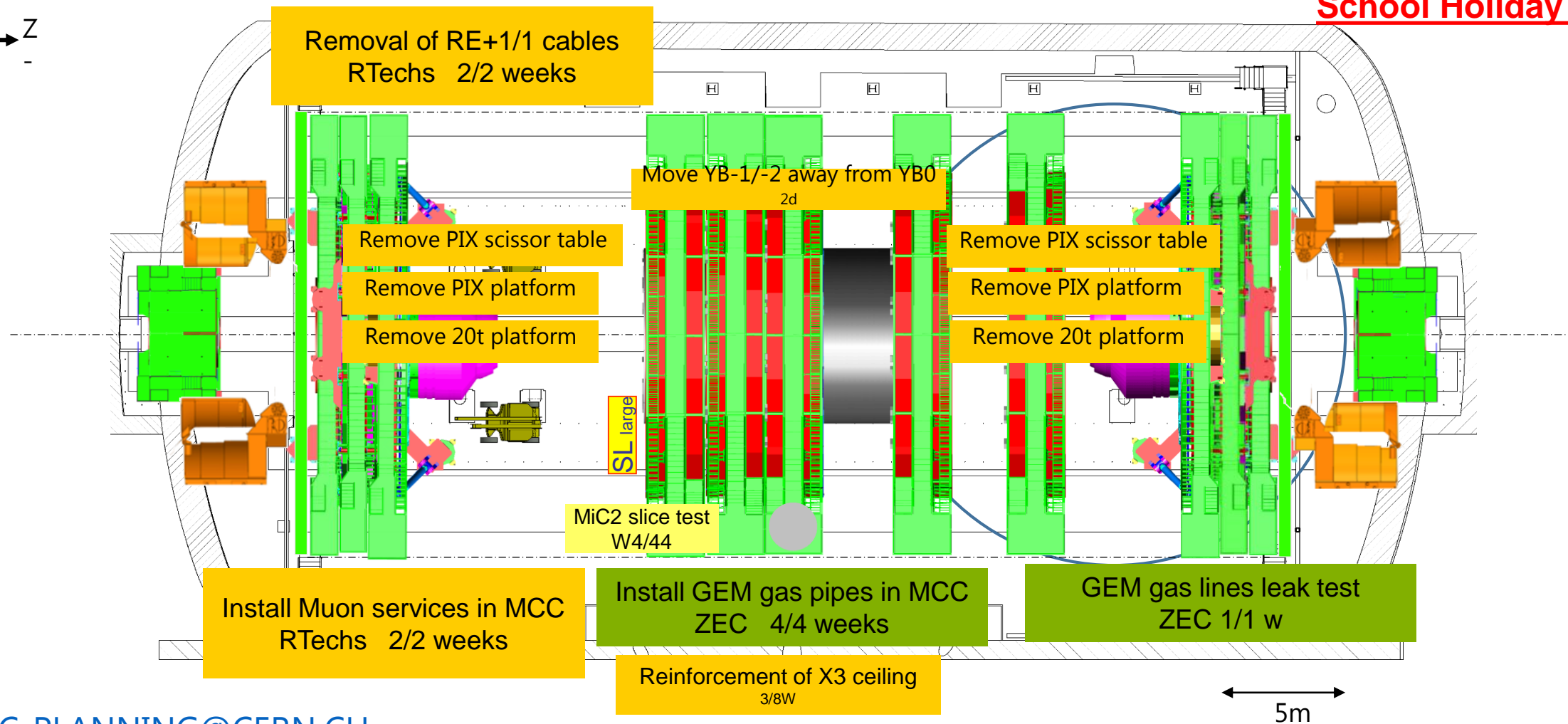



Crane

Cryo.	█	EL power	█	Water cool.	█	Database	█
IT	█	Magnet	█	C6F14	█	Gas	█
SL. 0	GEM	ECAL	ZEC	DT+ RB	Survey	TE-VSC	GS Dept
CP. 0	TOTEM	CMX	CSC RE	TK PIX	HCAL	EN Dept	RP

PX56 Plug CLOSED
TX54 Plug CLOSED

2019
February - Week 9

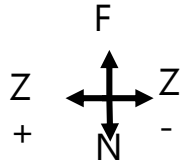

School Holiday FR

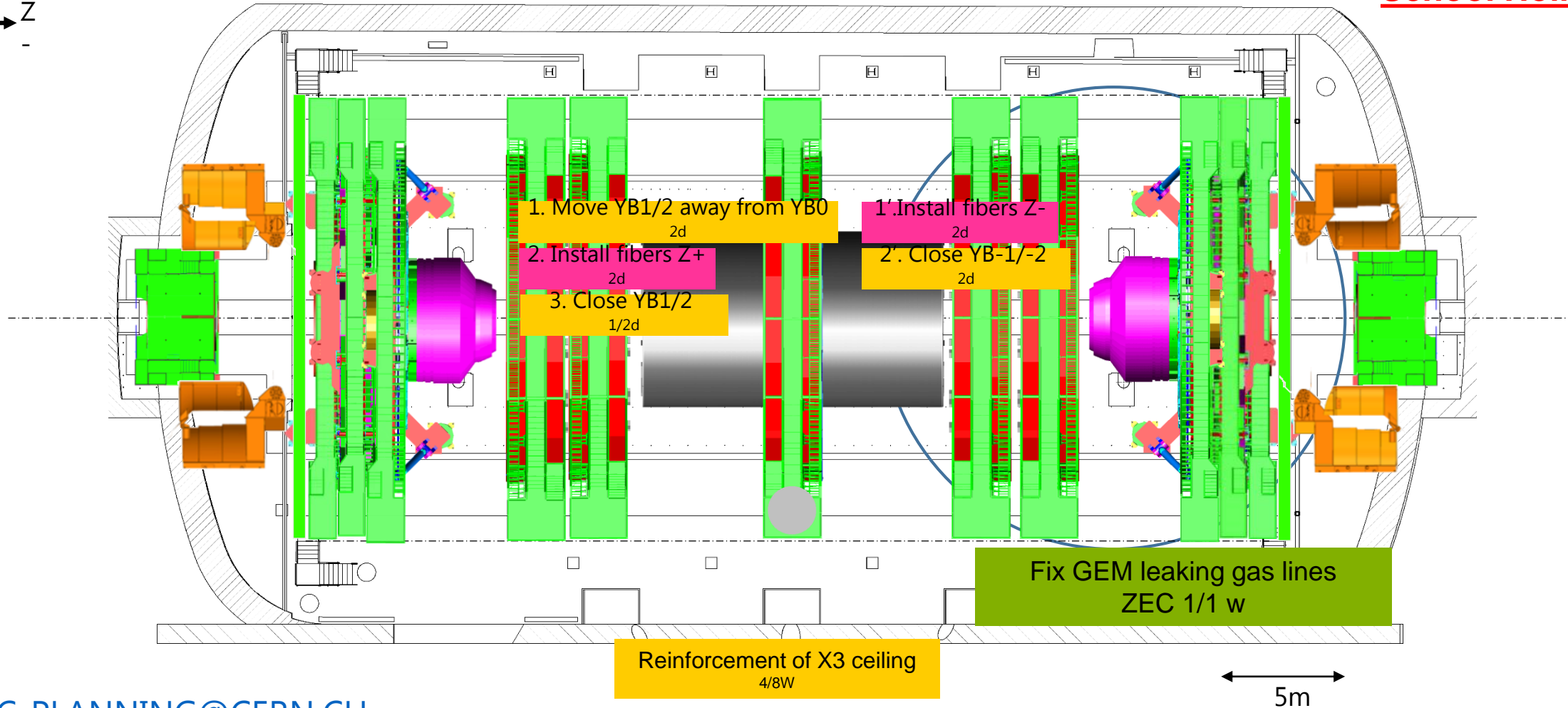



Crane

Cryo.	█	EL power	█	Water cool.	█	Database	█
IT	█	Magnet	█	C6F14	█	Gas	█
SL. 0	GEM	ECAL	ZEC	DT+ RB	Survey	TE-VSC	GS Dept
CP. 0	TOTEM	CMX	CSC RE	TK PIX	HCAL	EN Dept	RP

PX56 Plug CLOSED
TX54 Plug CLOSED

2019
March – Week 10

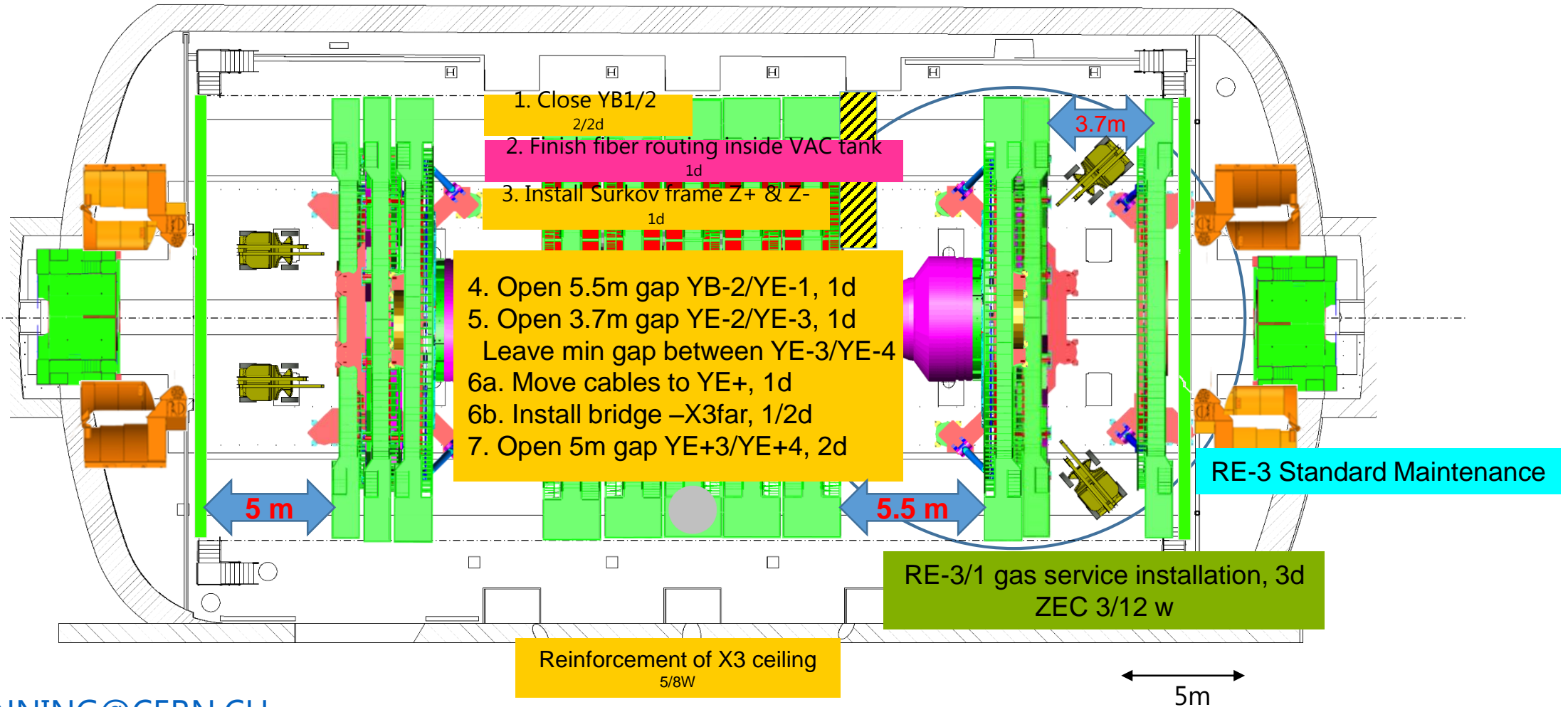
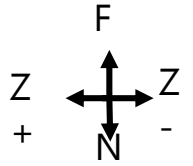



Crane

Cryo.	█	EL power	█	Water cool.	█	Database	█								
IT	█	Magnet	█	C6F14	█	Gas	█								
SL.	0	GEM	█	ECAL	█	ZEC	█	DT+ RB	█	Survey	█	TE-VSC	█	GS Dept	█
CP.	0	TOTEM	█	CMX	█	CSC RE	█	TK PIX	█	HCAL	█	EN Dept	█	RP	█

PX56 Plug CLOSED
TX54 Plug CLOSED

2019
March – Week 11

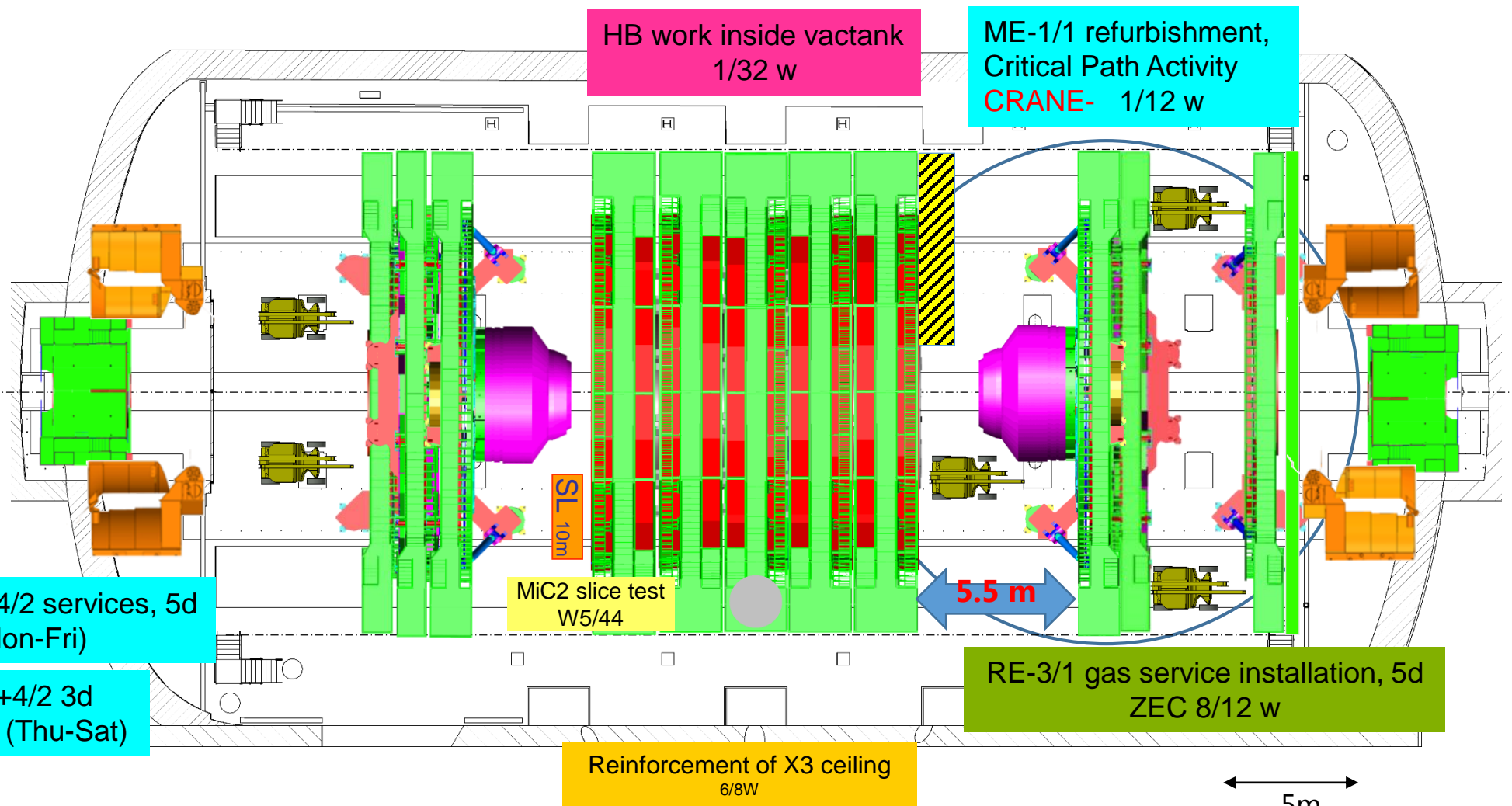
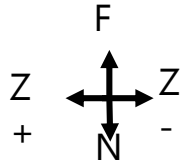

Disconnect RE+4/2 services, 5d
5/6 d (Mon-Fri)

Dismount RE+4/2 3d
CRANE+ 3/6 d (Thu-Sat)

Reinforcement of X3 ceiling
6/8W

RE-3/1 gas service installation, 5d
ZEC 8/12 w



Crane

Cryo.	█	EL power	█	Water cool.	█	Database	█								
IT	█	Magnet	█	C6F14	█	Gas	█								
SL.	0	GEM	█	ECAL	█	ZEC	█	DT+ RB	█	Survey	█	TE-VSC	█	GS Dept	█
CP.	0	TOTEM	█	CMX	█	CSC RE	█	TK PIX	█	HCAL	█	EN Dept	█	RP	█

PX56 Plug	CLOSED
TX54 Plug	CLOSED

2019
March – Week 12

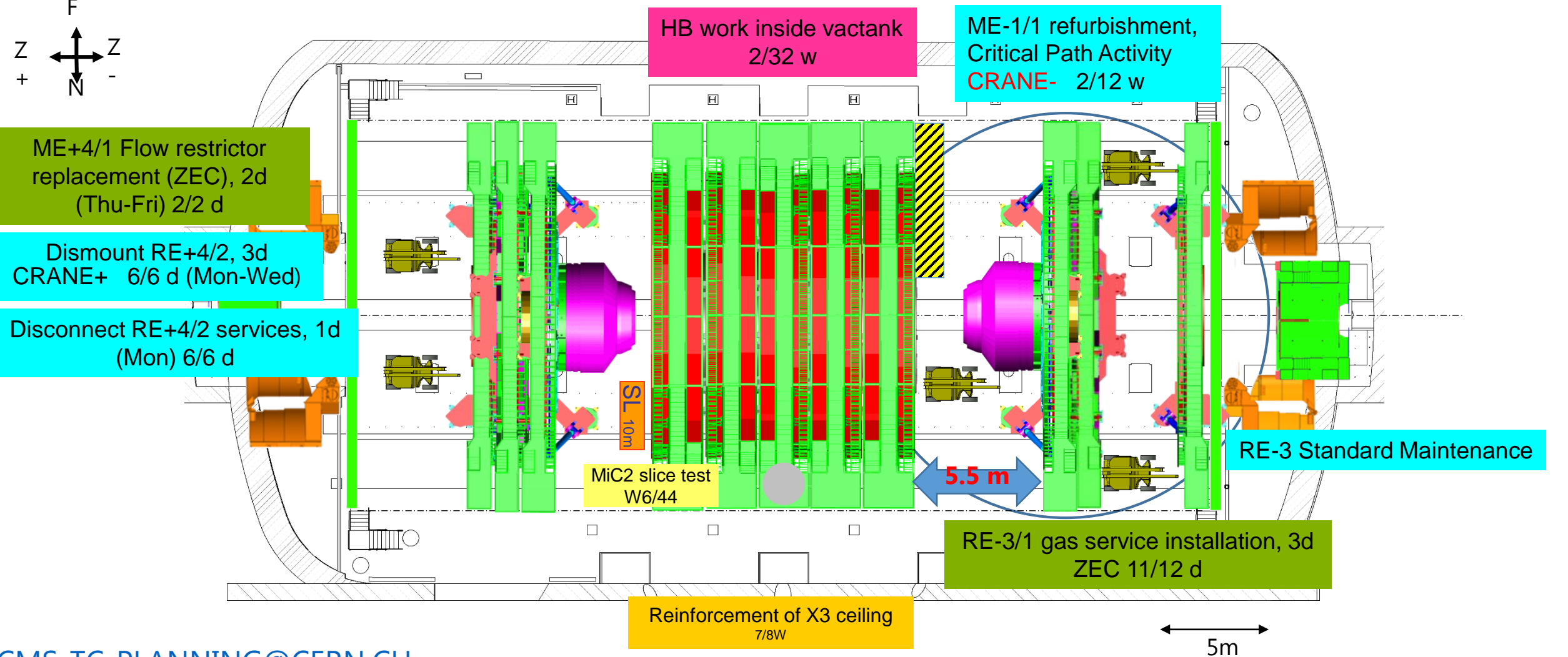
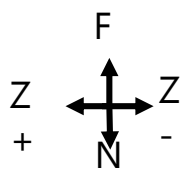



Crane

Cryo.	█	EL power	█	Water cool.	█	Database	█
IT	█	Magnet	█	C6F14	█	Gas	█
SL. 0	GEM	ECAL	ZEC	DT+ RB	Survey	TE-VSC	GS Dept
CP. 0	TOTEM	CMX	CSC RE	TK PIX	HCAL	EN Dept	RP

PX56 Plug CLOSED

2019

TX54 Plug CLOSED

March – Week 13

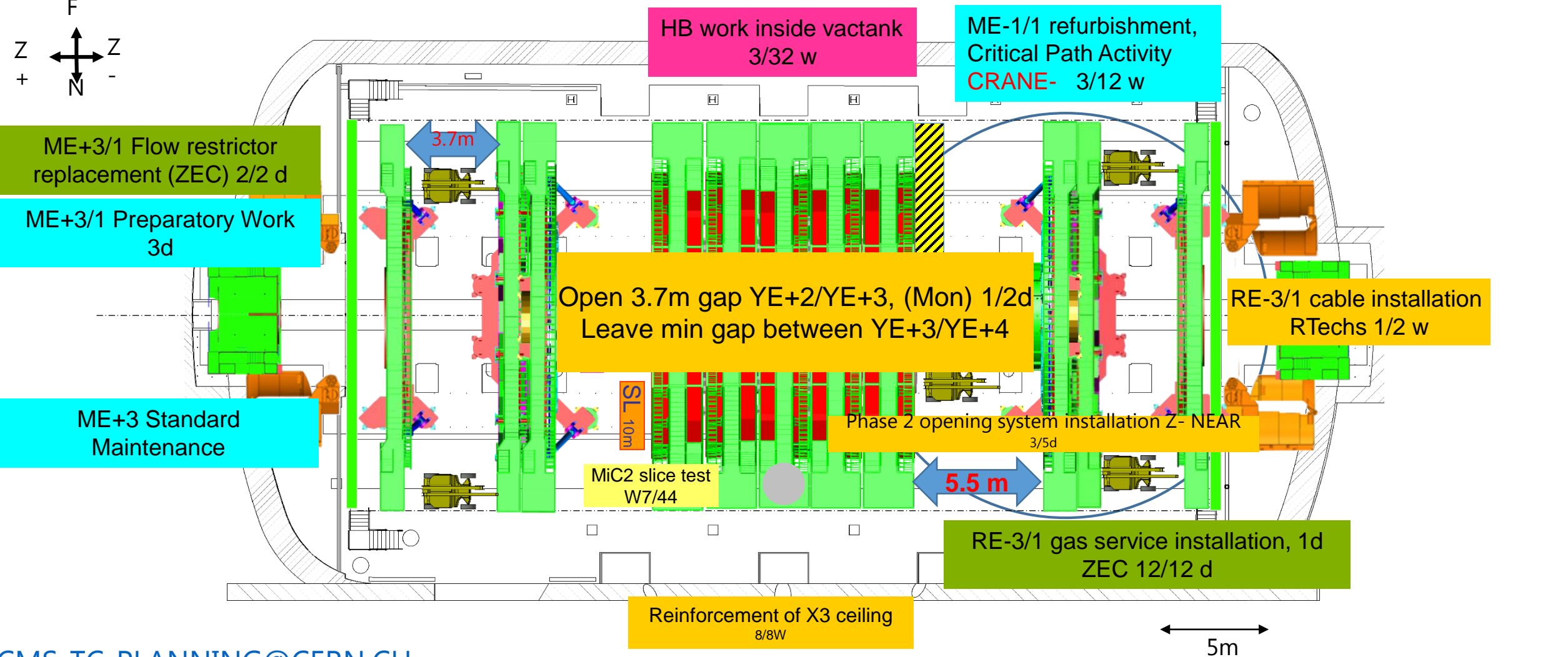
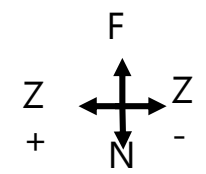



Crane

Cryo.	█	EL power	█	Water cool.	█	Database	█								
IT	█	Magnet	█	C6F14	█	Gas	█								
SL.	0	GEM	█	ECAL	█	ZEC	█	DT+ RB	█	Survey	█	TE-VSC	█	GS Dept	█
CP.	0	TOTEM	█	CMX	█	CSC RE	█	TK PIX	█	HCAL	█	EN Dept	█	RP	█

PX56 Plug
CLOSED

2019

TX54 Plug
CLOSED

April – Week 14

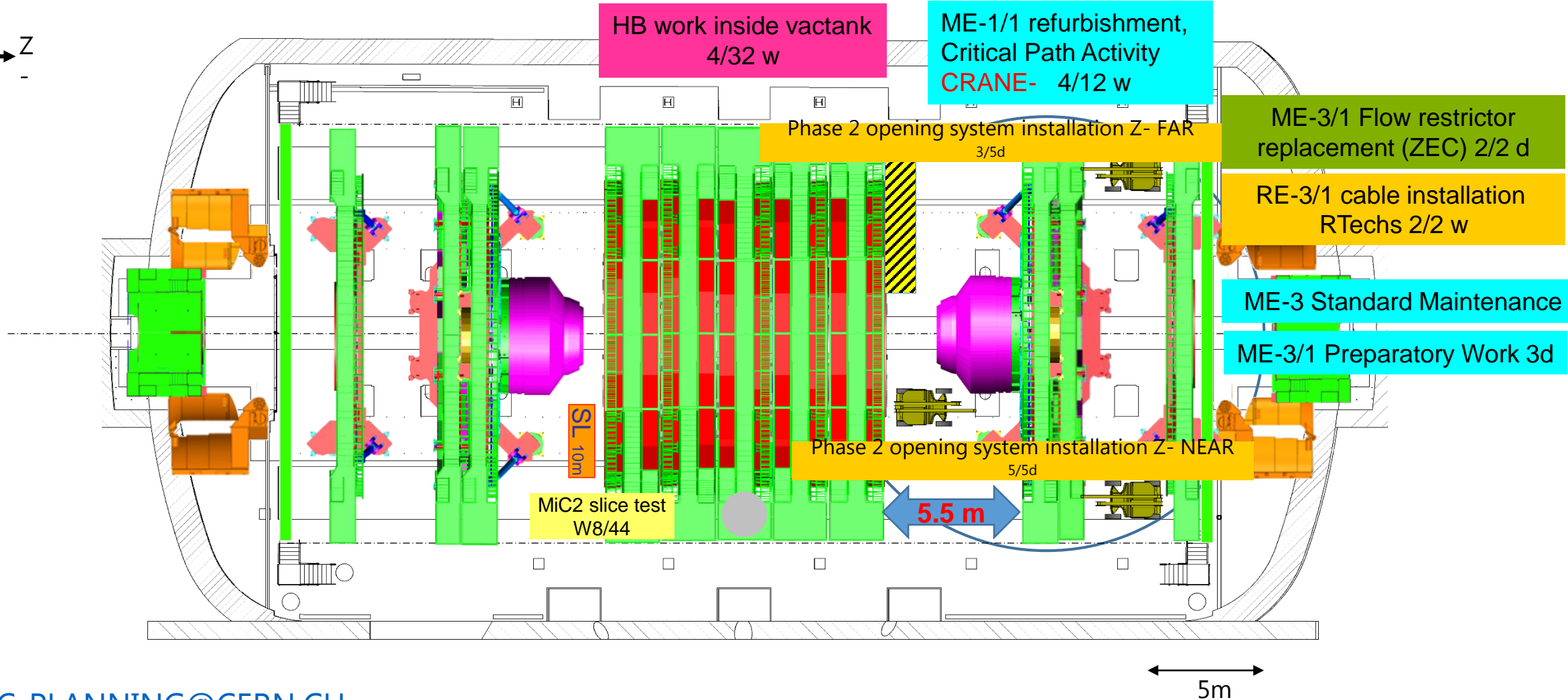
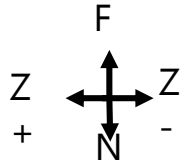



Crane

Cryo.	<input type="checkbox"/>	EL power	<input type="checkbox"/>	Water cool.	<input type="checkbox"/>	Database	<input type="checkbox"/>	
IT	<input type="checkbox"/>	Magnet	<input type="checkbox"/>	C6F14	<input type="checkbox"/>	Gas	<input type="checkbox"/>	
SL.	0	GEM	ECAL	ZEC	DT+ RB	Survey	TE-VSC	GS Dept
CP.	0	TOTEM	CMX	CSC RE	TK PIX	HCAL	EN Dept	RP

PX56 Plug CLOSED	2019
TX54 Plug CLOSED	April – Week 15

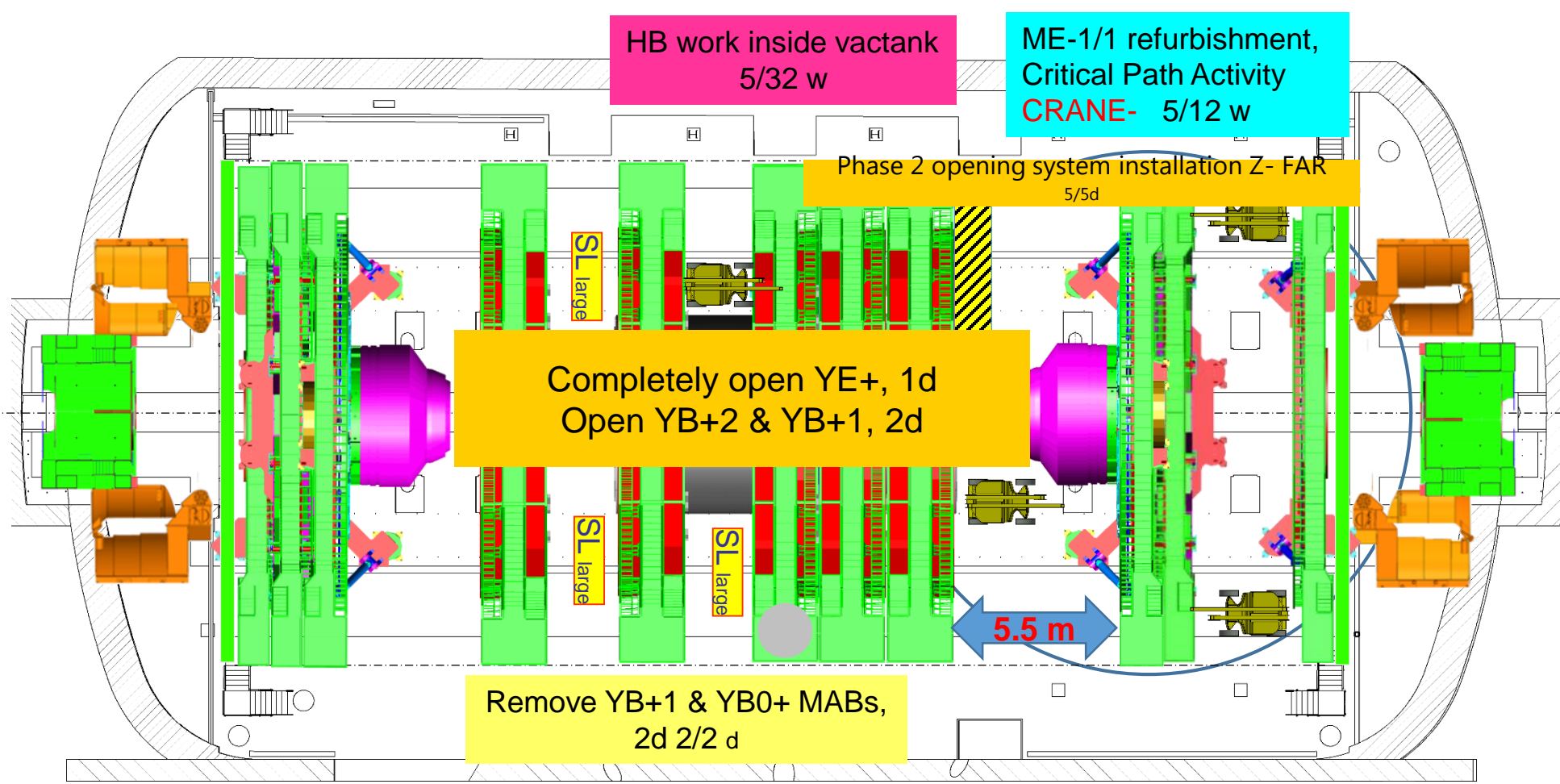
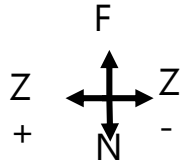

5m



Crane

Cryo.	█	EL power	█	Water cool.	█	Database	█
IT	█	Magnet	█	C6F14	█	Gas	█
SL. 0	GEM	ECAL	ZEC	DT+ RB	Survey	TE-VSC	GS Dept
CP. 0	TOTEM	CMX	CSC RE	TK PIX	HCAL	EN Dept	RP

PX56 Plug CLOSED
TX54 Plug CLOSED

2019
April – Week 16

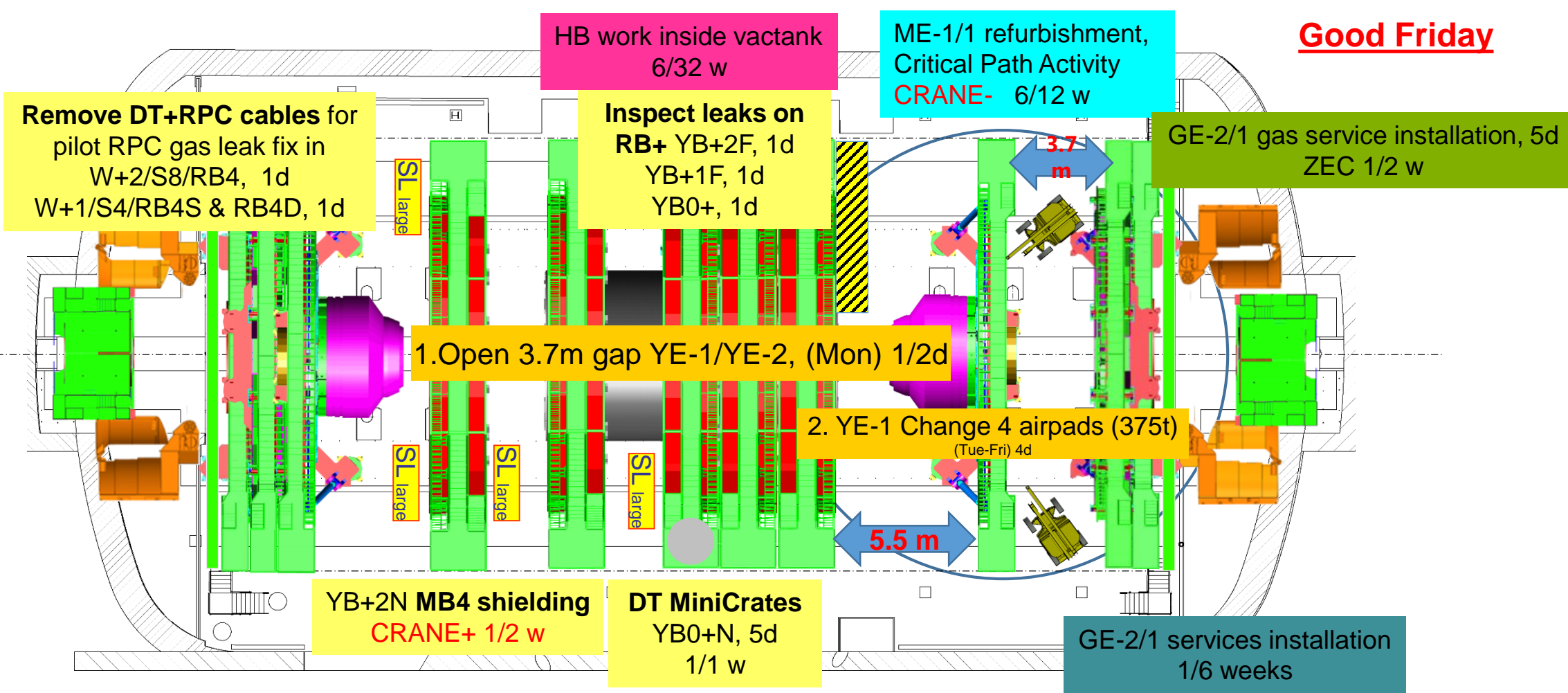
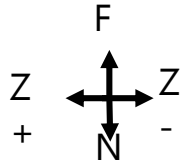

Good Friday



Crane

Cryo.	█	EL power	█	Water cool.	█	Database	█
IT	█	Magnet	█	C6F14	█	Gas	█
SL. 0	GEM	ECAL	ZEC	DT+ RB	Survey	TE-VSC	GS Dept
CP. 0	TOTEM	CMX	CSC RE	TK PIX	HCAL	EN Dept	RP

PX56 Plug
CLOSED

TX54 Plug
CLOSED

2019

April – Week 17

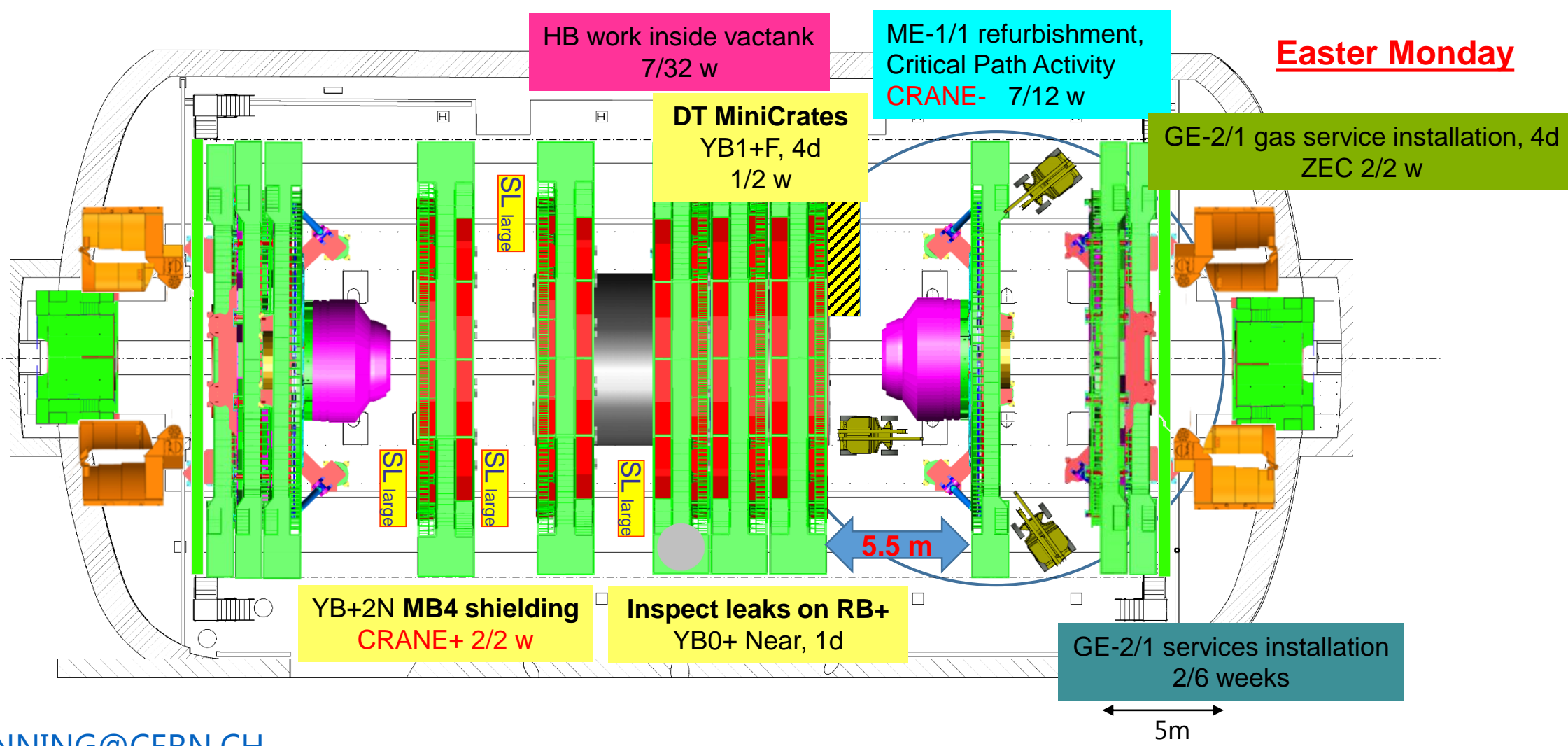
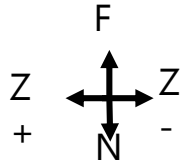

Easter Monday



Crane

Cryo.	█	EL power	█	Water cool.	█	Database	█								
IT	█	Magnet	█	C6F14	█	Gas	█								
SL.	0	GEM	█	ECAL	█	ZEC	█	DT+ RB	█	Survey	█	TE-VSC	█	GS Dept	█
CP.	0	TOTEM	█	CMX	█	CSC RE	█	TK PIX	█	HCAL	█	EN Dept	█	RP	█

PX56 Plug	CLOSED
TX54 Plug	CLOSED

2019
April – Week 18

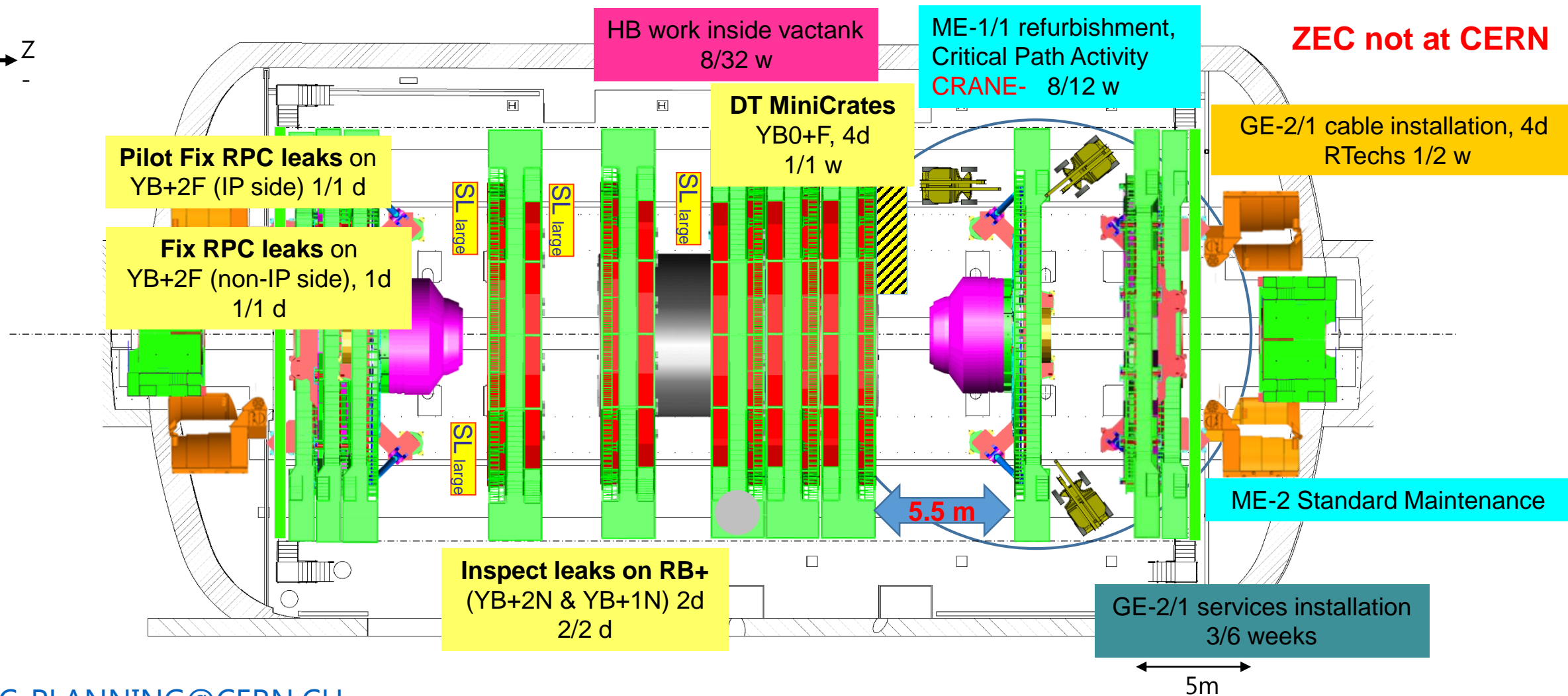
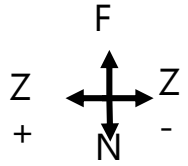



Crane

Cryo.	■	EL power	■	Water cool.	■	Database	■
IT	■	Magnet	■	C6F14	■	Gas	■
SL. 0	GEM	ECAL	ZEC	DT+ RB	Survey	TE-VSC	GS Dept
CP. 0	TOTEM	CMX	CSC RE	TK PIX	HCAL	EN Dept	RP

PX56 Plug CLOSED	2019
TX54 Plug CLOSED	May – Week 19

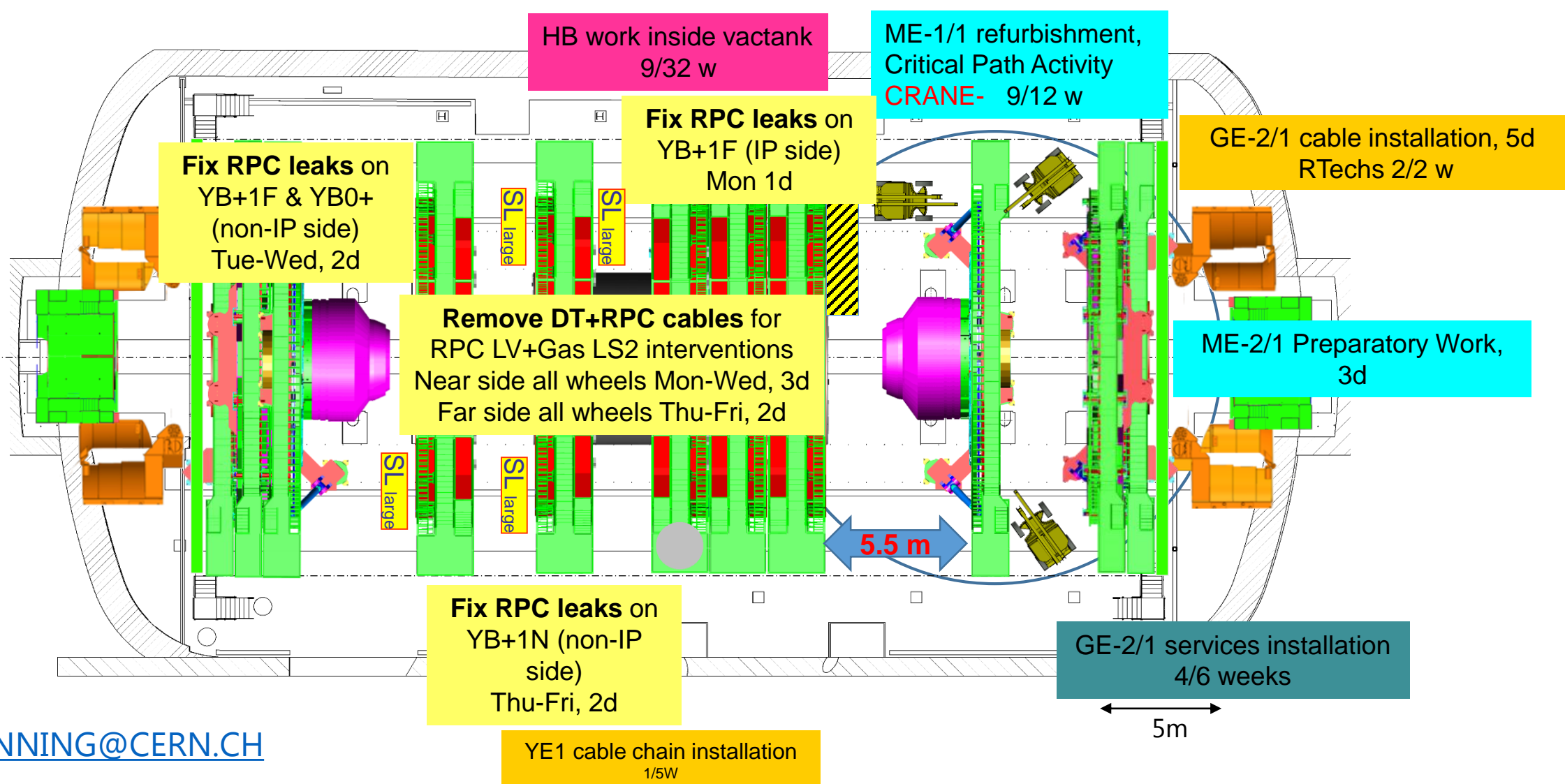
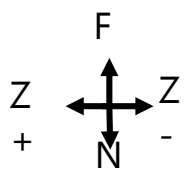



Cryo.	■	EL power	■	Water cool.	■	Database	■
IT	■	Magnet	■	C6F14	■	Gas	■
SL. 0	■ GEM	■ ECAL	■ ZEC	■ DT+ RB	■ Survey	■ TE-VSC	■ GS Dept
CP. 0	■ TOTEM	■ CMX	■ CSC RE	■ TK PIX	■ HCAL	■ EN Dept	RP

PX56 Plug
CLOSED

2019

TX54 Plug
CLOSED

May – Week 20

Crane

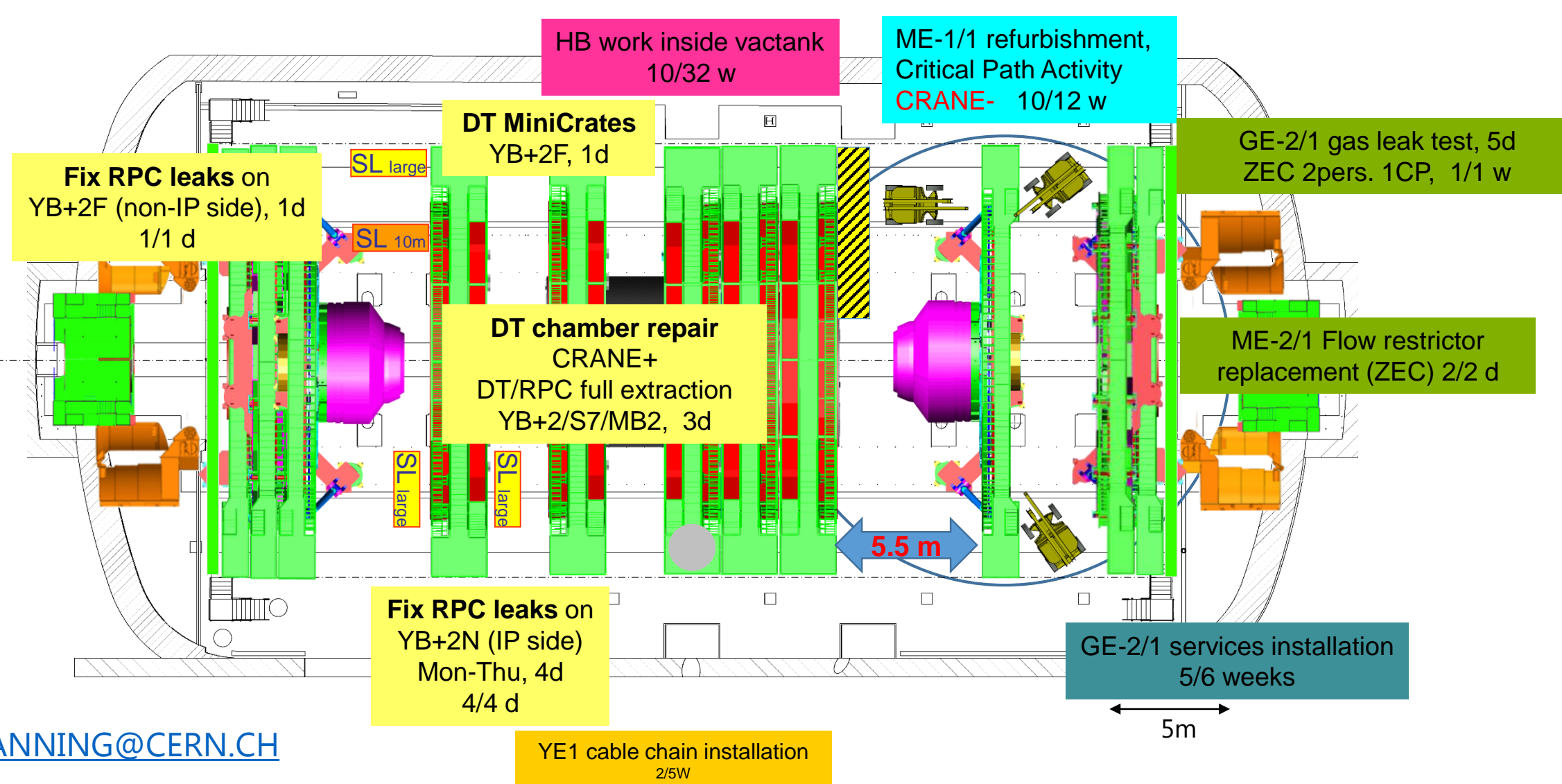
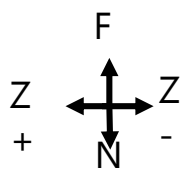



Crane

Cryo.	█	EL power	█	Water cool.	█	Database	█
IT	█	Magnet	█	C6F14	█	Gas	█
SL. 0	GEM	ECAL	ZEC	DT+ RB	Survey	TE-VSC	GS Dept
CP. 0	TOTEM	CMX	CSC RE	TK PIX	HCAL	EN Dept	RP

PX56 Plug
CLOSED

2019

TX54 Plug
CLOSED

May – Week 21

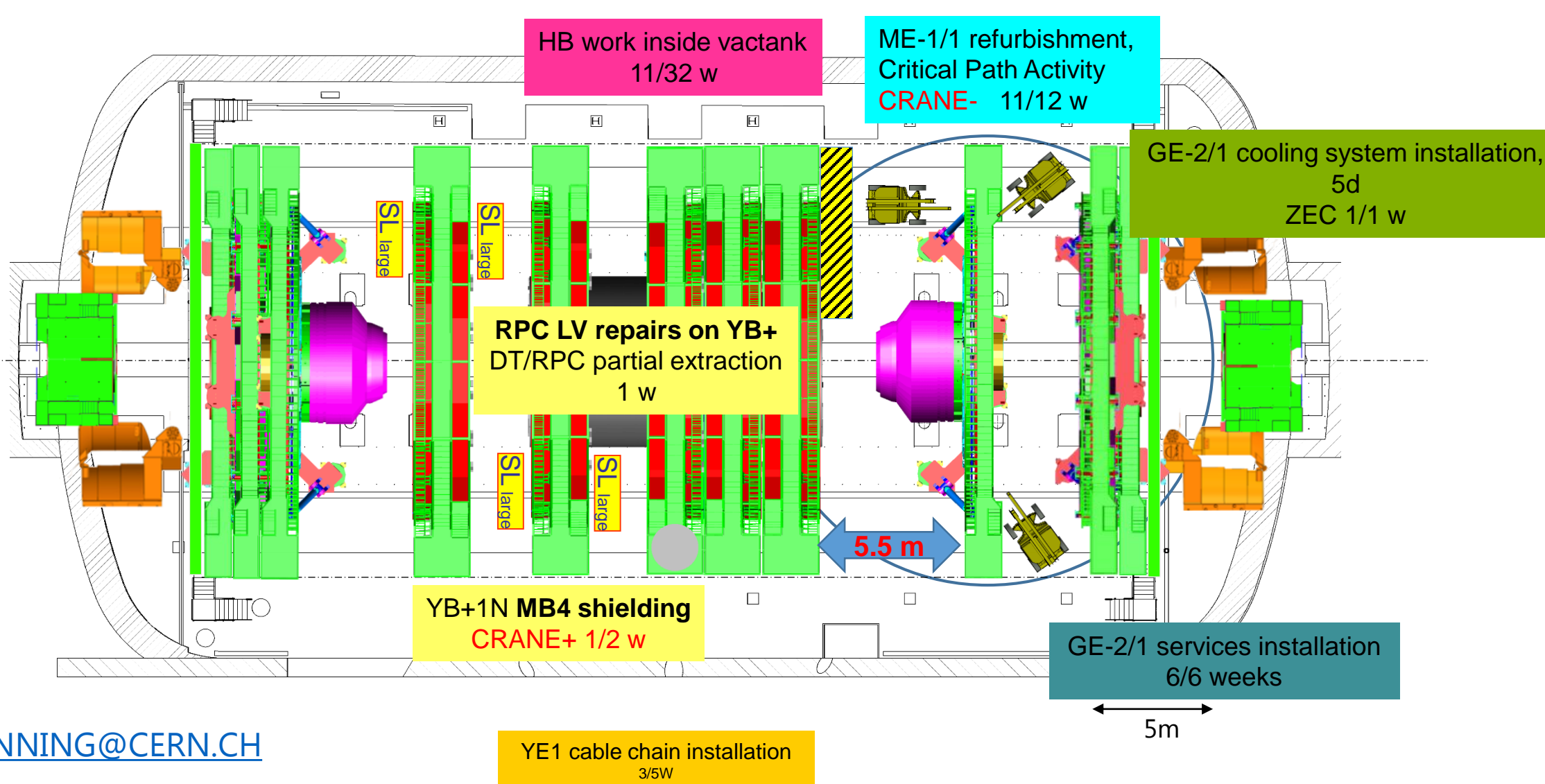
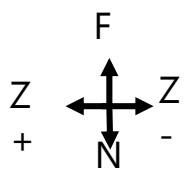



Cryo.	█	EL power	█	Water cool.	█	Database	█
IT	█	Magnet	█	C6F14	█	Gas	█
SL. 0	GEM	ECAL	ZEC	DT+ RB	Survey	TE-VSC	GS Dept
CP. 0	TOTEM	CMX	CSC RE	TK PIX	HCAL	EN Dept	RP

PX56 Plug CLOSED

2019

TX54 Plug CLOSED

May – Week 22

Crane

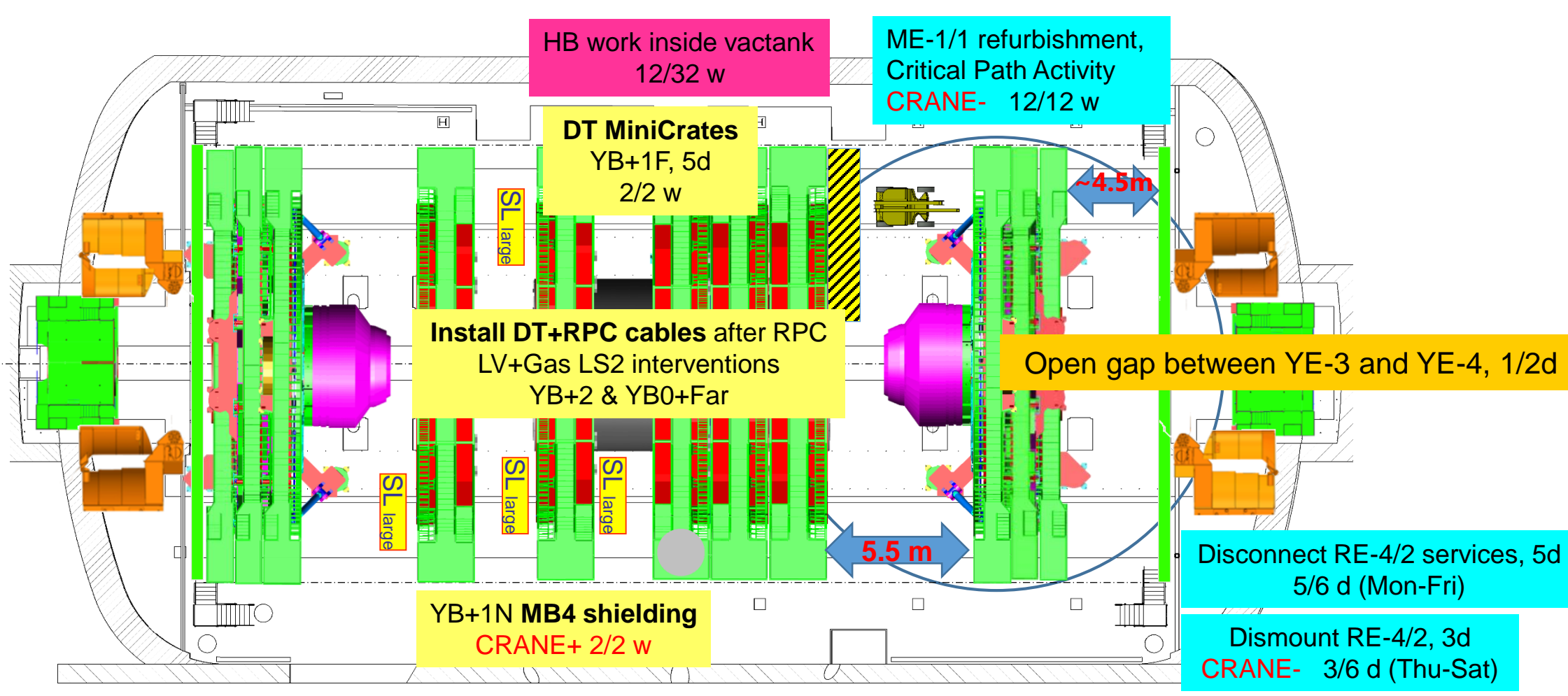
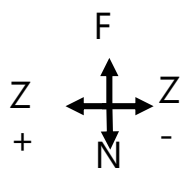



Cryo.	█	EL power	█	Water cool.	█	Database	█								
IT	█	Magnet	█	C6F14	█	Gas	█								
SL.	0	GEM	█	ECAL	█	ZEC	█	DT+ RB	█	Survey	█	TE-VSC	█	GS Dept	█
CP.	0	TOTEM	█	CMX	█	CSC RE	█	TK PIX	█	HCAL	█	EN Dept	█	RP	█

PX56 Plug CLOSED	2019
TX54 Plug CLOSED	June – Week 23

Crane

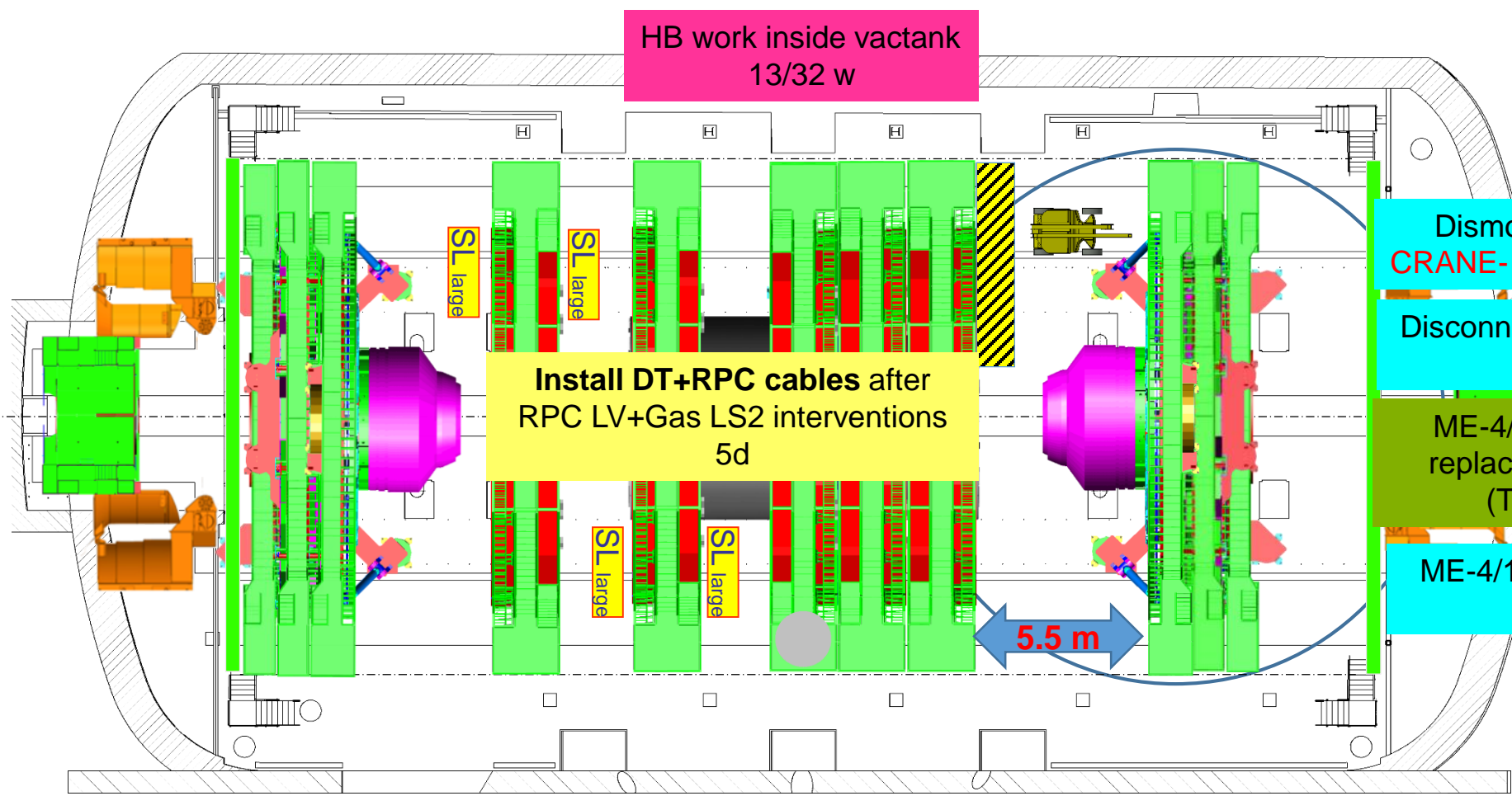
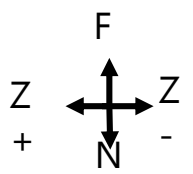

- Dismount RE-4/2, 3d
CRANE- 6/6 d (Mon-Wed)
- Disconnect RE-4/2 services, 1d
(Mon) 6/6 d
- ME-4/1 Flow restrictor replacement (ZEC), 2d
(Thu-Fri) 2/2 d
- ME-4/1 Preparatory Work, 2d

5m



Cryo.	█	EL power	█	Water cool.	█	Database	█								
IT	█	Magnet	█	C6F14	█	Gas	█								
SL.	0	GEM	█	ECAL	█	ZEC	█	DT+ RB	█	Survey	█	TE-VSC	█	GS Dept	█
CP.	0	TOTEM	█	CMX	█	CSC RE	█	TK PIX	█	HCAL	█	EN Dept	█	RP	█

PX56 Plug
CLOSED

TX54 Plug
CLOSED

2019

June – Week 24

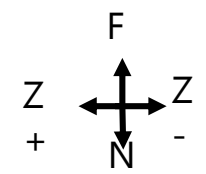

Disconnect Front ME+2/1 services, 1d (Thu) 1/1 d

Dismount 9 Front ME+2/1, 1d CRANE+ 1/2 d

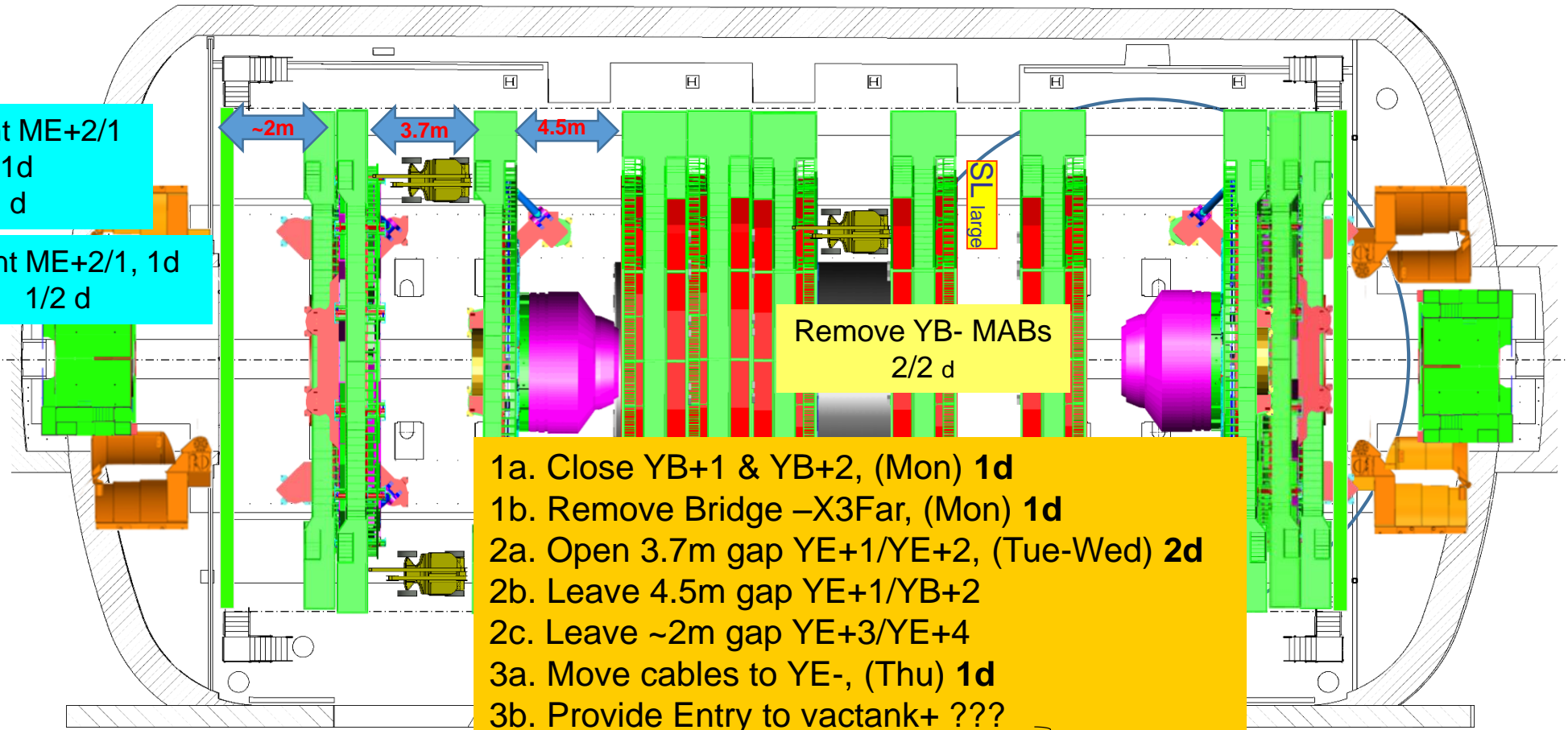

Test new YE+ cable chains?

- 1a. Close YB+1 & YB+2, (Mon) 1d
- 1b. Remove Bridge -X3Far, (Mon) 1d
- 2a. Open 3.7m gap YE+1/YE+2, (Tue-Wed) 2d
- 2b. Leave 4.5m gap YE+1/YB+2
- 2c. Leave ~2m gap YE+3/YE+4
- 3a. Move cables to YE-, (Thu) 1d
- 3b. Provide Entry to vactank+ ???
- 4. Close YE-, 2d
- 5. Open YB-2 & YB-1, 1d

2d in W25

5m



Crane

Cryo.	█	EL power	█	Water cool.	█	Database	█								
IT	█	Magnet	█	C6F14	█	Gas	█								
SL.	0	GEM	█	ECAL	█	ZEC	█	DT+ RB	█	Survey	█	TE-VSC	█	GS Dept	█
CP.	0	TOTEM	█	CMX	█	CSC RE	█	TK PIX	█	HCAL	█	EN Dept	█	RP	█

PX56 Plug	CLOSED
TX54 Plug	CLOSED

2019
June – Week 25

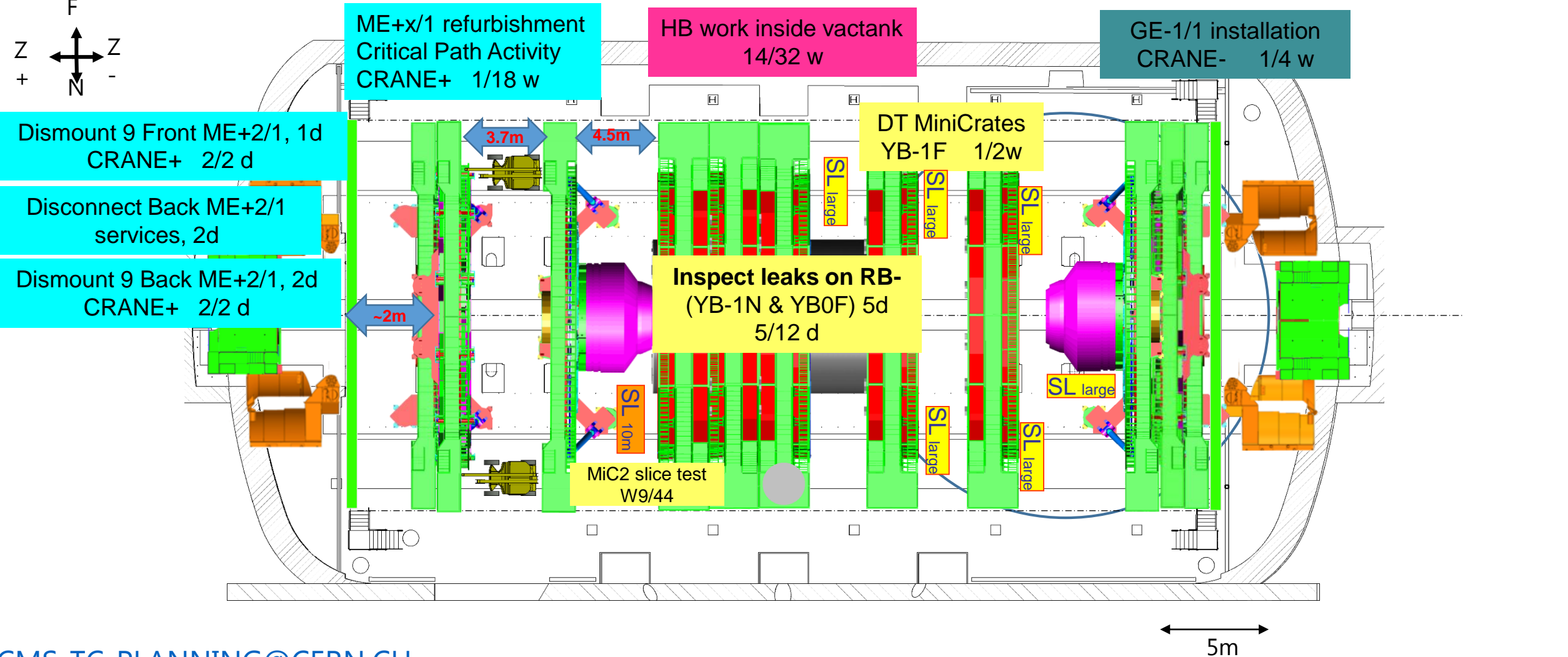
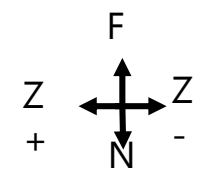

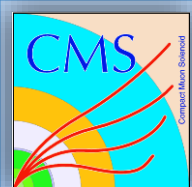

Crane

Cryo.	█	EL power	█	Water cool.	█	Database	█								
IT	█	Magnet	█	C6F14	█	Gas	█								
SL.	0	GEM	█	ECAL	█	ZEC	█	DT+ RB	█	Survey	█	TE-VSC	█	GS Dept	█
CP.	0	TOTEM	█	CMX	█	CSC RE	█	TK PIX	█	HCAL	█	EN Dept	█	RP	█

PX56 Plug CLOSED
TX54 Plug CLOSED

2019
June – Week 26

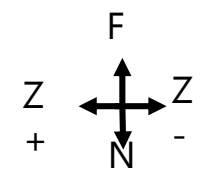

Move YE+2 disk towards YE1
Leave 3.7m gap YE+2/YE+3
1/2 d (Mon)

Disconnect 9 Front ME+3/1
services, 1d
(Tue) 1/1 d

Dismount 9 Front ME+3/1, 2d
CRANE+ (Wed-Thu) 2/2 d

Disconnect 9 Back ME+3/1
services, 1d
(Fri) 2/2 d

ME+x/1 refurbishment
Critical Path Activity
CRANE+ 2/18 w

HB work inside vactank
15/32 w

GE-1/1 installation
CRANE- 2/4 w

DT MiniCrates
YB0-F 1/1 w

Inspect leaks on RB-
(YB-1F & YB0N) 4d
(YB-2N) 1d
10/12 d

MiC2 slice test
W10/44

Phase 2 opening system installation Z+ NEAR
4/5d

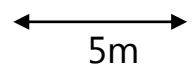
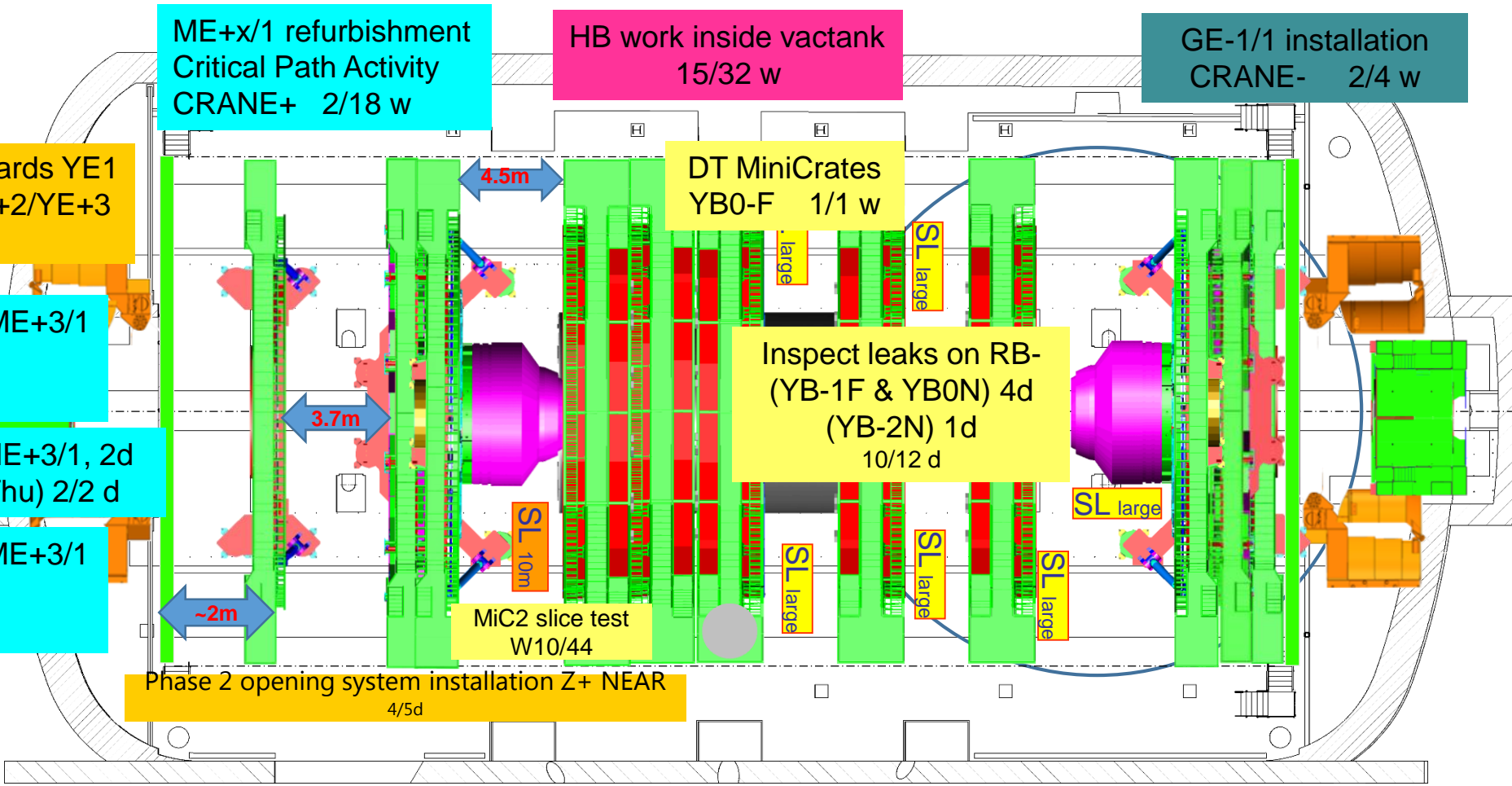



Crane

Cryo.	█	EL power	█	Water cool.	█	Database	█
IT	█	Magnet	█	C6F14	█	Gas	█
SL. 0	GEM	ECAL	ZEC	DT+ RB	Survey	TE-VSC	GS Dept
CP. 0	TOTEM	CMX	CSC RE	TK PIX	HCAL	EN Dept	RP

PX56 Plug CLOSED	2019
TX54 Plug CLOSED	July – Week 27

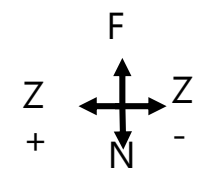

- Disconnect 9 Back ME+3/1 services, 1d (Mon) 2/2 d
- Dismount 9 Back ME+3/1, 2d CRANE+ (Tue-Wed) 2/2 d
- Disconnect Front ME+4/1 services, 2d (Tue-Wed) 2/2 d

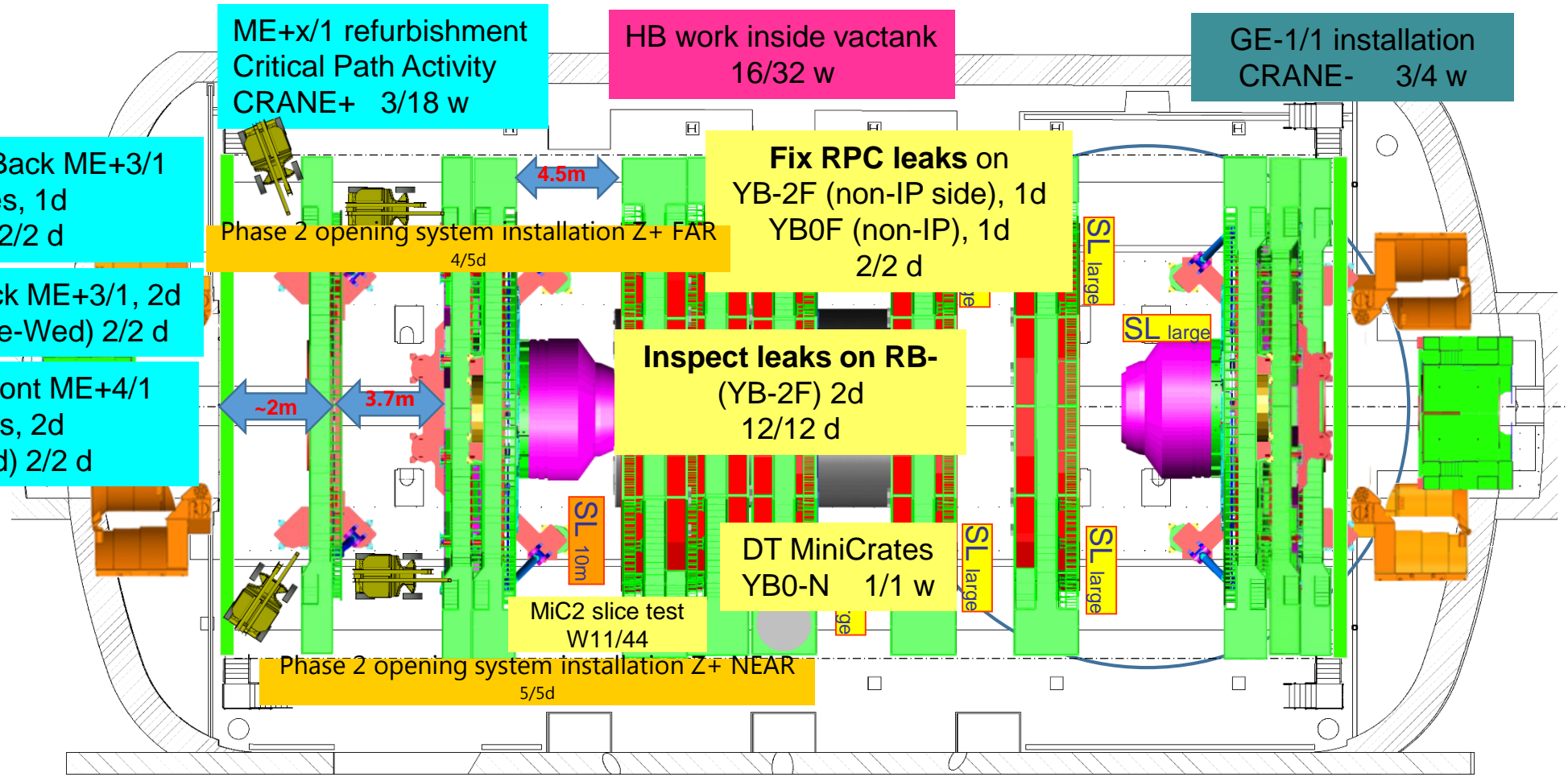

Remove DT+RPC cables for RPC LV+Gas LS2 interventions in YB-1
1/2 w

5m



Cryo.	■	EL power	■	Water cool.	■	Database	■
IT	■	Magnet	■	C6F14	■	Gas	■
SL. 0	GEM	ECAL	ZEC	DT+ RB	Survey	TE-VSC	GS Dept
CP. 0	TOTEM	CMX	CSC RE	TK PIX	HCAL	EN Dept	RP

PX56 Plug
CLOSED

2019

TX54 Plug
CLOSED

July – Week 28

Crane

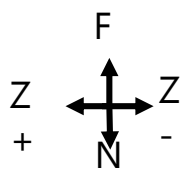

1. Move YE+3 disk towards YE2
Leave ~5m gap YE+3/YE+4
Leave ~1m gap YE+2/YE+3
(Thu) 1 d

Dismount 9 Front ME+4/1, 1d
CRANE+ (Tue-Wed) 2/2 d

Disconnect 9 Back ME+4/1
services, 2d
(Wed-Thu) 2/2 d

Dismount 9 Back ME+4/1, 1d
CRANE+ (Fri) 1/2 d

ME+x/1 refurbishment
Critical Path Activity
CRANE+ 4/18 w

GE-1/1 installation
CRANE- 4/4 w

Phase 2 opening system installation Z+ FAR
(Mon) 5/5d

DT MiniCrates
YB-1F 2/2 w

Fix RPC leaks on YB-1N
(IP side), 5d
5/5 d

MiC2 slice test
W12/44

Remove DT+RPC cables for RPC
LV+Gas LS2 interventions in YB-2
2/2 w

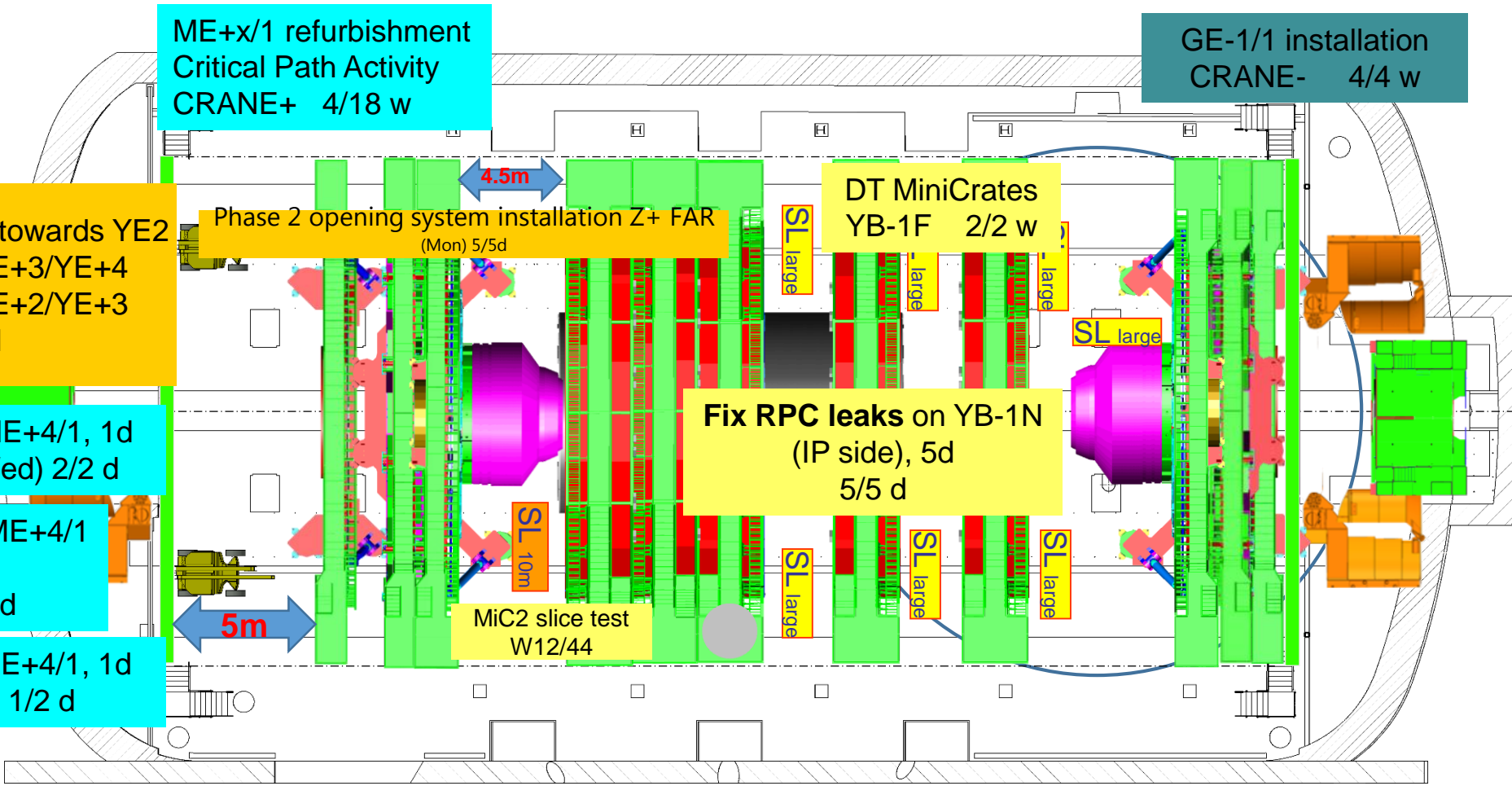

5m



Crane

Cryo.	█	EL power	█	Water cool.	█	Database	█								
IT	█	Magnet	█	C6F14	█	Gas	█								
SL.	0	GEM	█	ECAL	█	ZEC	█	DT+ RB	█	Survey	█	TE-VSC	█	GS Dept	█
CP.	0	TOTEM	█	CMX	█	CSC RE	█	TK PIX	█	HCAL	█	EN Dept	█	RP	█

PX56 Plug
CLOSED

2019

TX54 Plug
CLOSED

July – Week 29

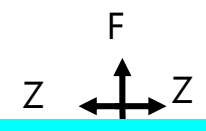

Dismount 9 Back ME+4/1, 1d
CRANE+ (Mon) 2/2 d

1. Move YE+3 disk towards YE4
 2. Move YE+2 disk towards YE3
- Leave 3.7m gap YE+1/YE+2
Leave ~2.3m gap YE+3/YE+4
(Tue) 1 d

Install 9 BACK ME+2/1, 2d
CRANE+ (Wed-Thu) 2/2 d

Cabling & Connectivity
9 BACK ME+2/1, 1d
(Fri) 1/4 d

Install RE+4/1 gas services, 5d
ZEC, 5/10 d

ME+x/1 refurbishment
Critical Path Activity
CRANE+ 5/18 w

GE-1/1 service installation
1/7 week

GE-1/1 gas service installation, 5d
ZEC 1/2 w

Fix RPC leaks on YB-1F
(IP side), 5d
5/10 d

YE+1 Change 4 airpads (375t)
(Thu-Fri) 2/4d

DT MiniCrates
YB-1N 1/2 w

MiC2 slice test
W13/44

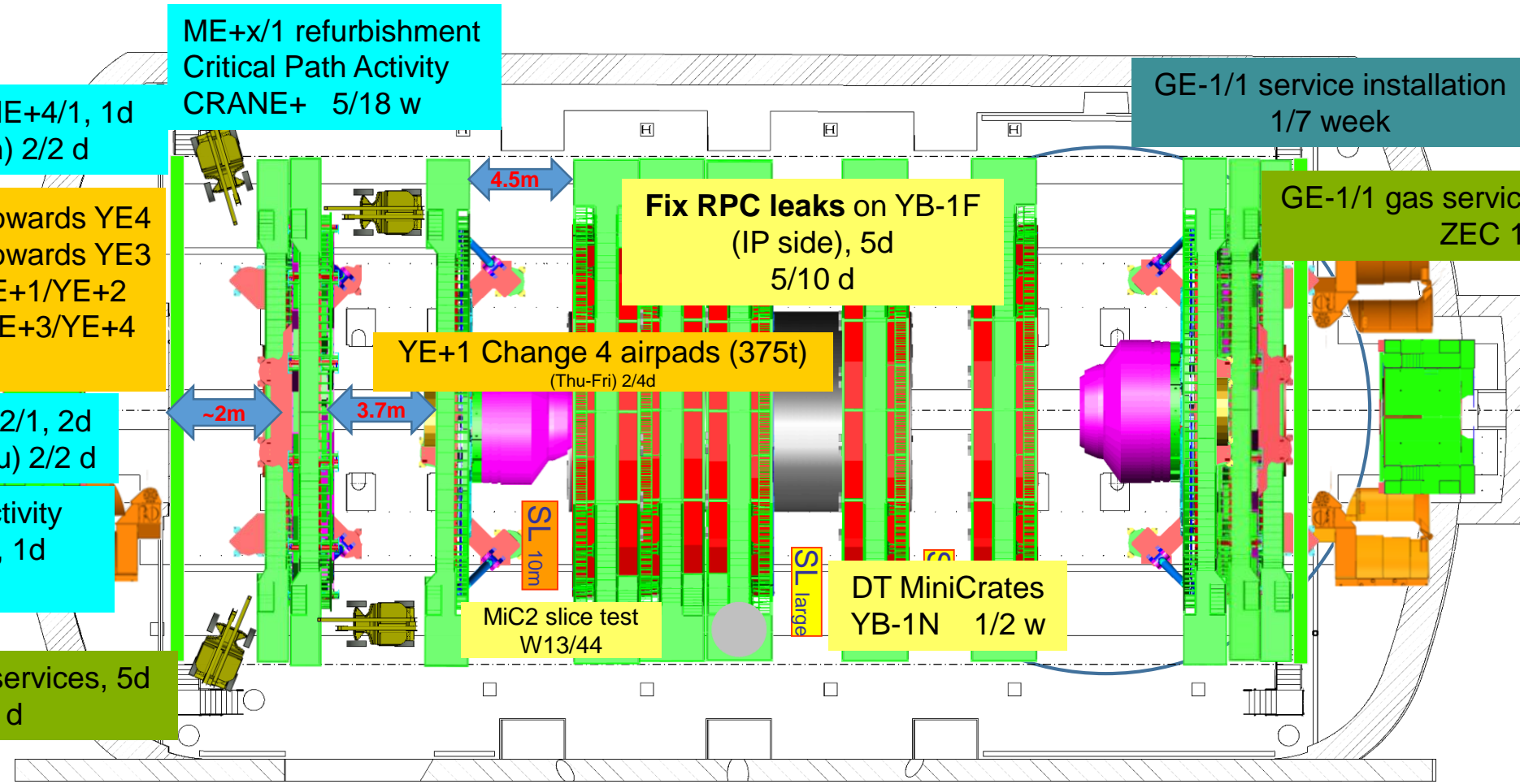



Crane

Cryo.		EL power		Water cool.		Database		
IT		Magnet		C6F14		Gas		
SL.	0	GEM	ECAL	ZEC	DT+ RB	Survey	TE-VSC	GS Dept
CP.	0	TOTEM	CMX	CSC RE	TK PIX	HCAL	EN Dept	RP

PX56 Plug CLOSED
TX54 Plug CLOSED

2019
July – Week 30

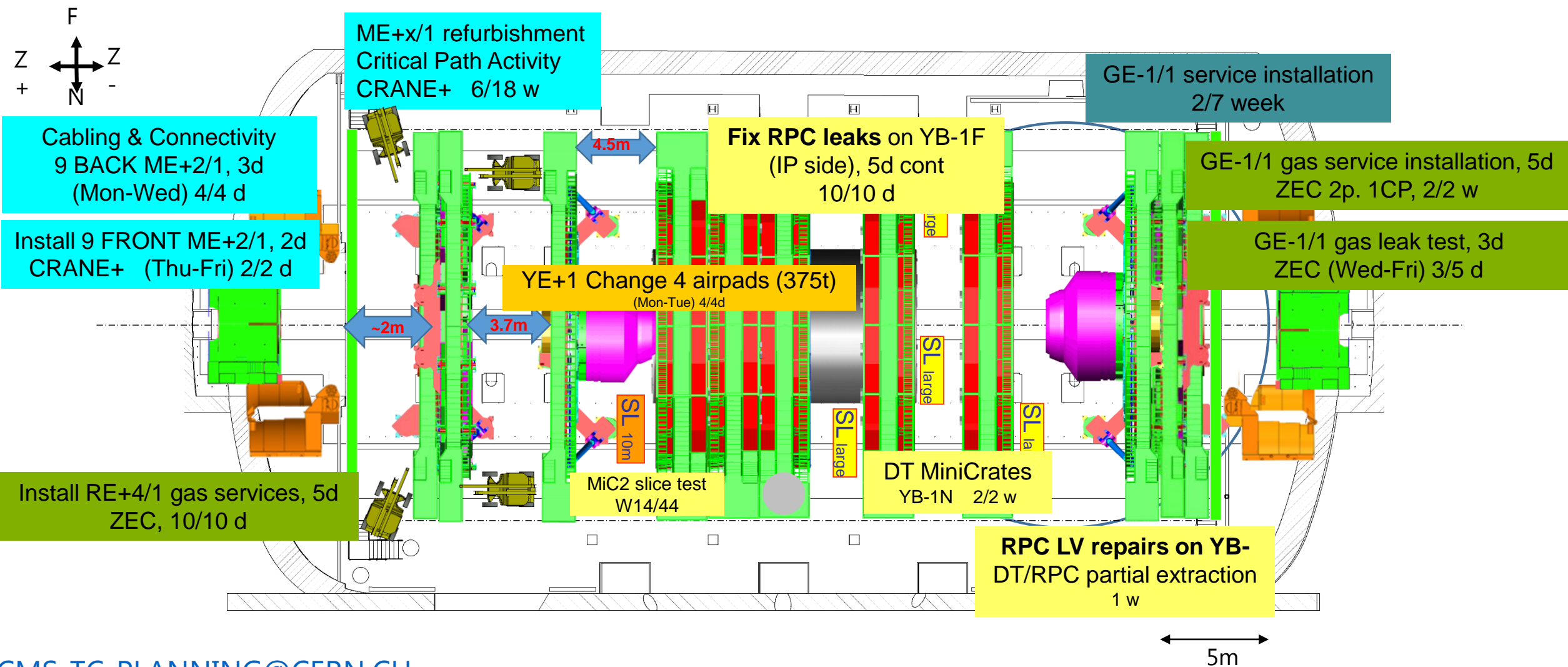



Crane

Cryo.	█	EL power	█	Water cool.	█	Database	█
IT	█	Magnet	█	C6F14	█	Gas	█
SL. 0	GEM	ECAL	ZEC	DT+ RB	Survey	TE-VSC	GS Dept
CP. 0	TOTEM	CMX	CSC RE	TK PIX	HCAL	EN Dept	RP

PX56 Plug CLOSED

2019

TX54 Plug CLOSED

July – Week 31

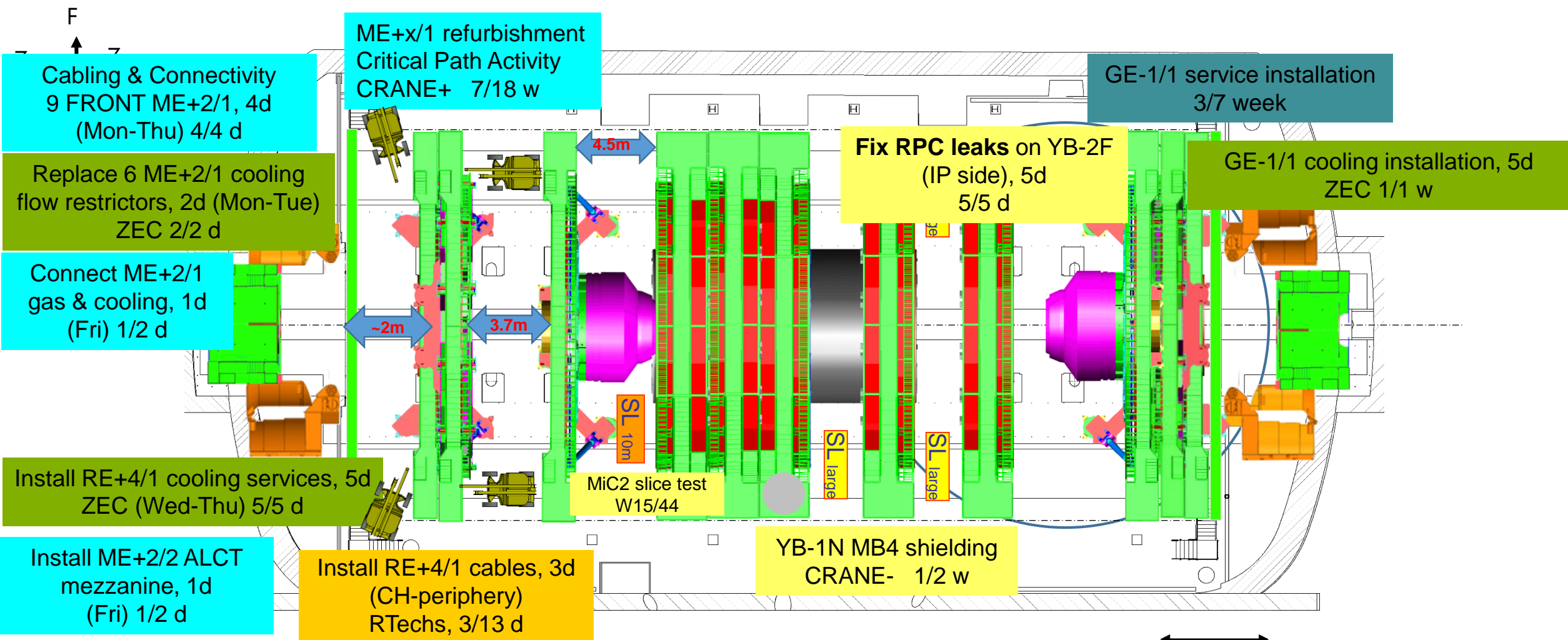



Cryo.	█	EL power	█	Water cool.	█	Database	█
IT	█	Magnet	█	C6F14	█	Gas	█
SL. 0	GEM	ECAL	ZEC	DT+ RB	Survey	TE-VSC	GS Dept
CP. 0	TOTEM	CMX	CSC RE	TK PIX	HCAL	EN Dept	RP

PX56 Plug
CLOSED

TX54 Plug
CLOSED

2019

August – Week 32

Crane

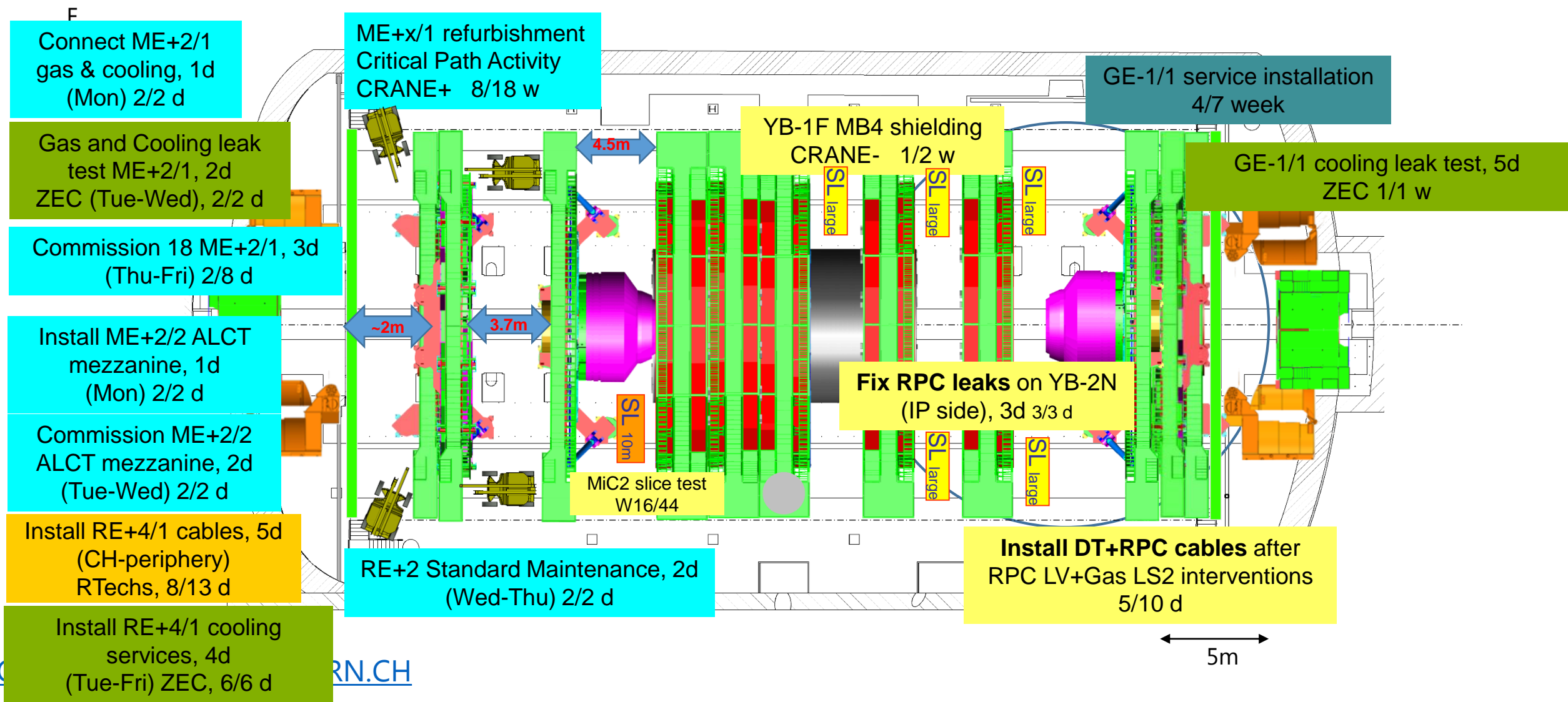



Crane

Cryo.	<input type="checkbox"/>	EL power	<input type="checkbox"/>	Water cool.	<input type="checkbox"/>	Database	<input type="checkbox"/>
IT	<input type="checkbox"/>	Magnet	<input type="checkbox"/>	C6F14	<input type="checkbox"/>	Gas	<input type="checkbox"/>
SL. 0	GEM	ECAL	ZEC	DT+ RB	Survey	TE-VSC	GS Dept
CP. 0	TOTEM	CMX	CSC RE	TK PIX	HCAL	EN Dept	RP

PX56 Plug
CLOSED

TX54 Plug
CLOSED

2019

August – Week 33

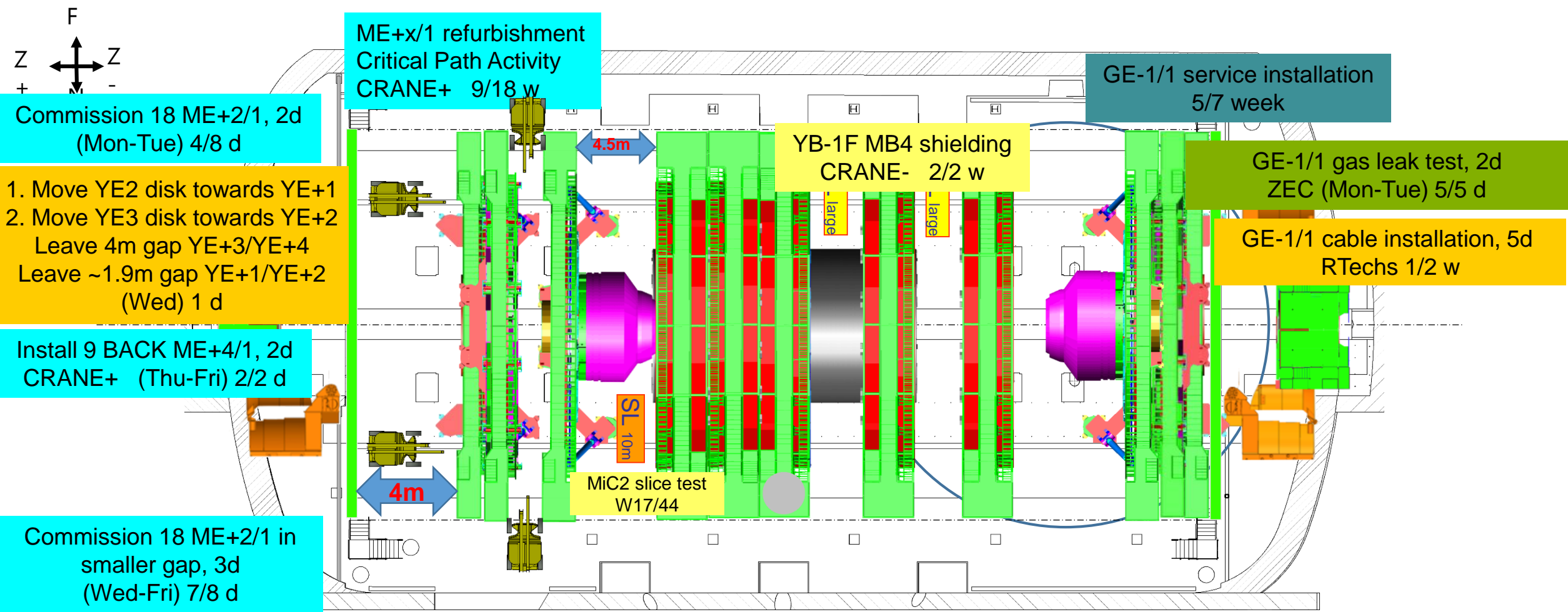



Crane

Cryo.	█	EL power	█	Water cool.	█	Database	█
IT	█	Magnet	█	C6F14	█	Gas	█
SL. 0	GEM	ECAL	ZEC	DT+ RB	Survey	TE-VSC	GS Dept
CP. 0	TOTEM	CMX	CSC RE	TK PIX	HCAL	EN Dept	RP

PX56 Plug
CLOSED

2019

TX54 Plug
CLOSED

August – Week 34

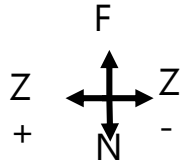

ME+x/1 refurbishment
Critical Path Activity
CRANE+ 10/18 w

GE-1/1 service installation
6/7 week

Commission 18 ME+2/1 in
smaller gap, 1d
(Mon) 8/8 d

Cabling & Connectivity
9 BACK ME+4/1, 4d
(Mon-Thu) 4/4 d

Install 9 FRONT ME+4/1, 1d
CRANE+ (Fri) 1/2 d

GE-1/1 cable installation, 5d
RTechs 2/2 w

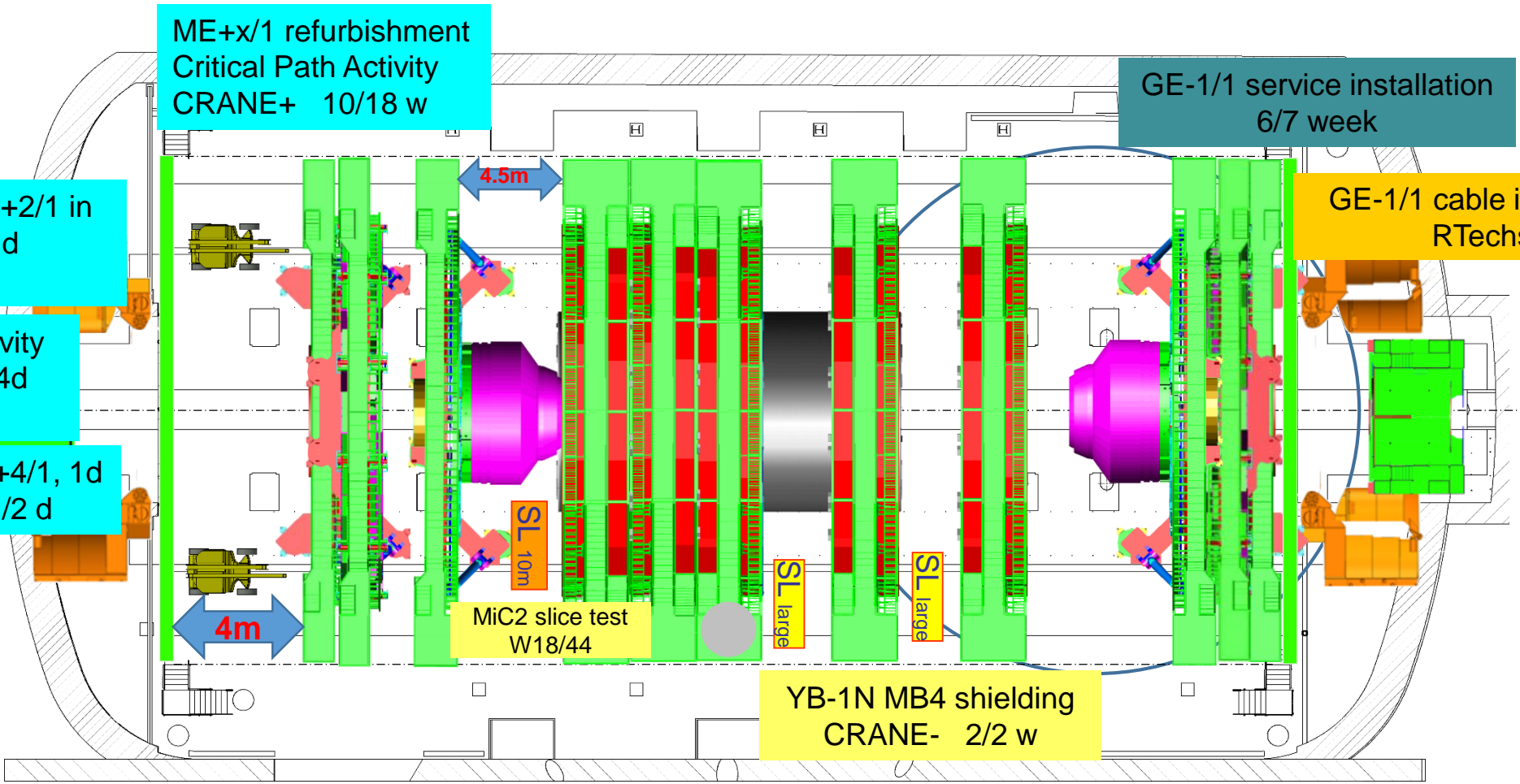

YB-1N MB4 shielding
CRANE- 2/2 w

5m



Crane

Cryo.	█	EL power	█	Water cool.	█	Database	█
IT	█	Magnet	█	C6F14	█	Gas	█
SL. 0	GEM	ECAL	ZEC	DT+ RB	Survey	TE-VSC	GS Dept
CP. 0	TOTEM	CMX	CSC RE	TK PIX	HCAL	EN Dept	RP

PX56 Plug
CLOSED

TX54 Plug
CLOSED

2019

August – Week 35

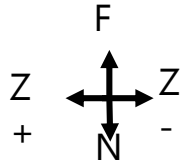

- Install 9 FRONT ME+4/1, 1d
CRANE+ (Mon) 2/2 d
- Cabling & Connectivity
9 FRONT ME+4/1, 3d
(Tue-Thu) 3/3 d
- Connect ME+4/1
gas & cooling, 1d
(Fri) 1/2 d
- Replace 6 ME+4/1 cooling
flow restrictors, 2d (Wed-Thu)
ZEC 2/2 d

ME+x/1 refurbishment
Critical Path Activity
CRANE+ 11/18 w

GE-1/1 service installation
7/7 week

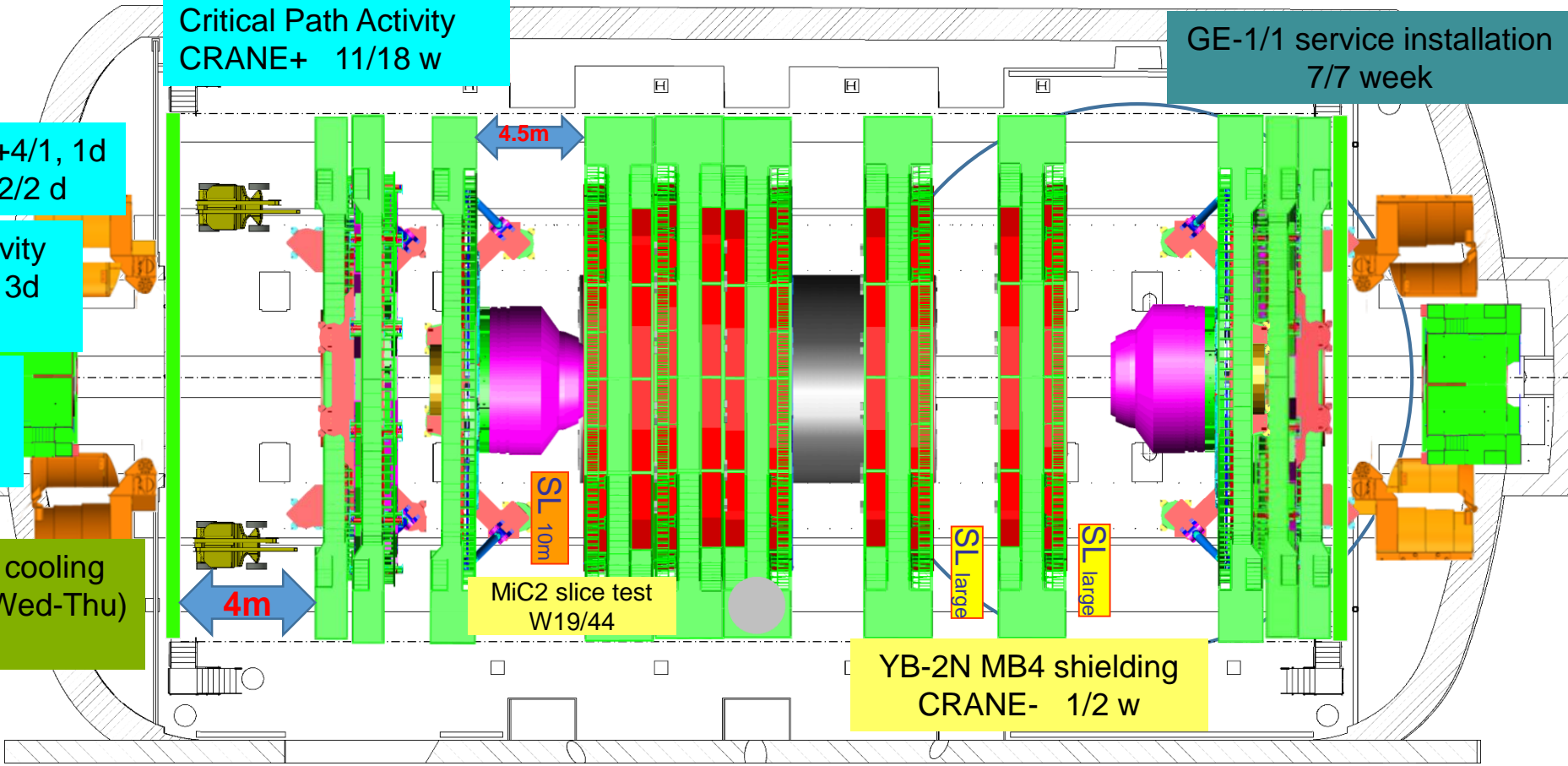

5m



Crane

Cryo.	█	EL power	█	Water cool.	█	Database	█								
IT	█	Magnet	█	C6F14	█	Gas	█								
SL.	0	GEM	█	ECAL	█	ZEC	█	DT+ RB	█	Survey	█	TE-VSC	█	GS Dept	█
CP.	0	TOTEM	█	CMX	█	CSC RE	█	TK PIX	█	HCAL	█	EN Dept	█	RP	█

PX56 Plug
CLOSED

TX54 Plug
CLOSED

2019

September – Week 36

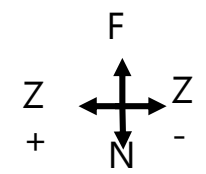

Connect ME+4/1
gas & cooling, 1d
(Mon) 2/2 d

Gas and Cooling leak
test ME+4/1, 2d
ZEC (Tue-Wed) 2/2 d

Commission 18 ME+4/1, 2d
(Thu-Fri) 2/8 d

ME+x/1 refurbishment
Critical Path Activity
CRANE+ 12/18 w

HB work inside vactank
17/32 w

GE-1/1 commissioning
1/6 week

Jeune Genevois

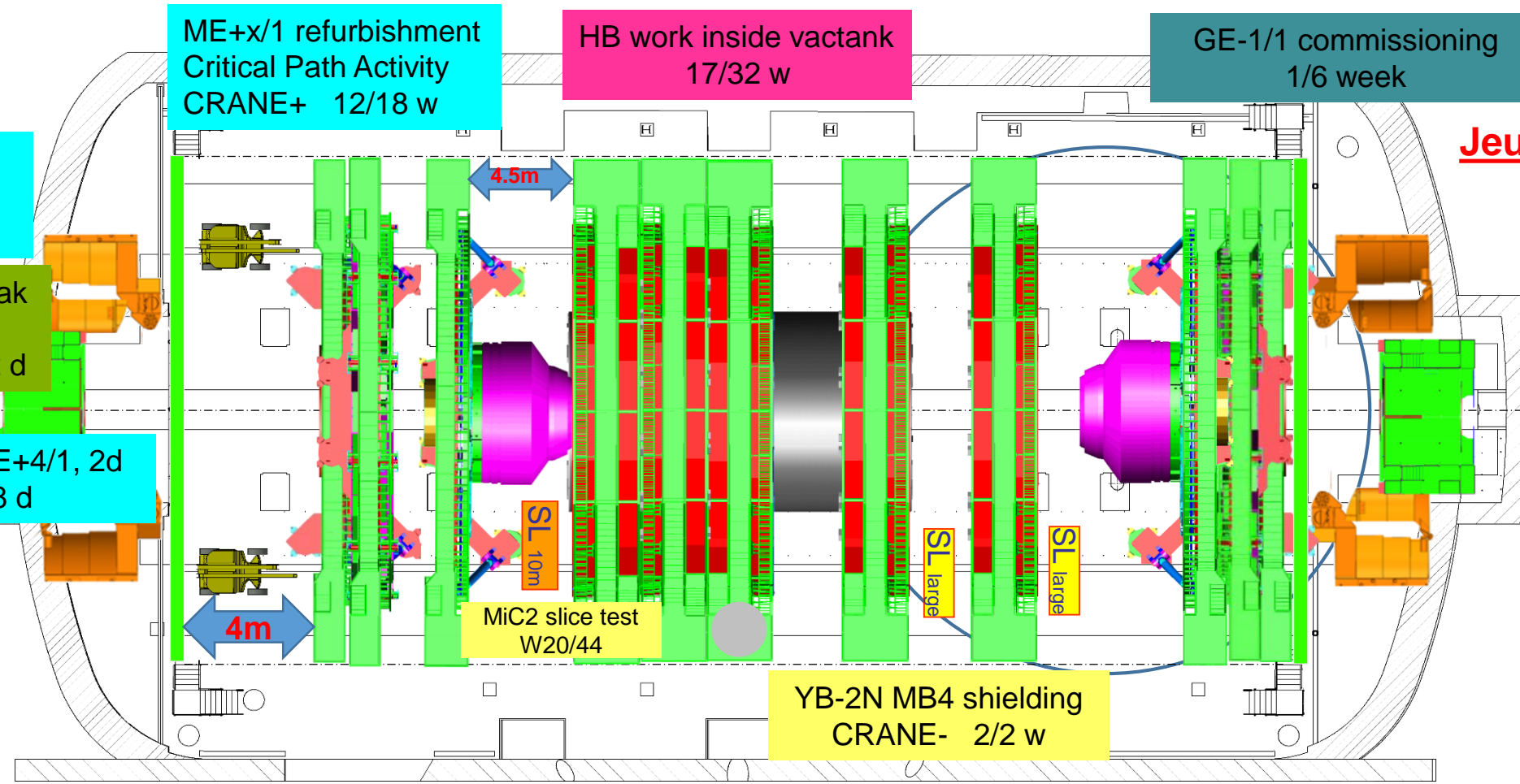

5m



2019

September – Week 37

Cryo.	█	EL power	█	Water cool.	█	Database	█
IT	█	Magnet	█	C6F14	█	Gas	█
SL. 0	GEM	ECAL	ZEC	DT+ RB	Survey	TE-VSC	GS Dept
CP. 0	TOTEM	CMX	CSC RE	TK PIX	HCAL	EN Dept	RP

PX56 Plug
CLOSED

TX54 Plug
CLOSED

Crane

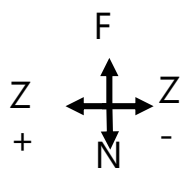

CERN OPEN DAYS
Weekend++

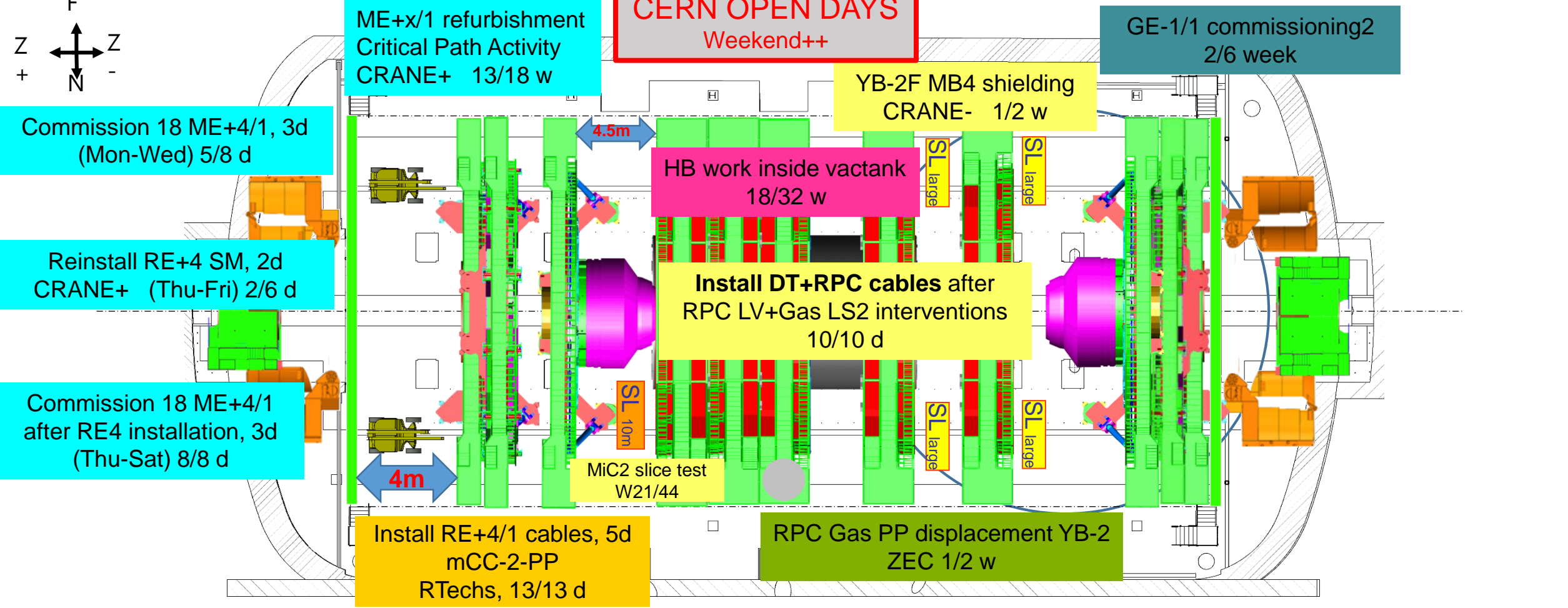

ME+x/1 refurbishment
Critical Path Activity
CRANE+ 13/18 w

GE-1/1 commissioning2
2/6 week

YB-2F MB4 shielding
CRANE- 1/2 w

Commission 18 ME+4/1, 3d
(Mon-Wed) 5/8 d

HB work inside vactank
18/32 w

Reinstall RE+4 SM, 2d
CRANE+ (Thu-Fri) 2/6 d

Install DT+RPC cables after
RPC LV+Gas LS2 interventions
10/10 d

Commission 18 ME+4/1
after RE4 installation, 3d
(Thu-Sat) 8/8 d

SL 10m

MiC2 slice test
W21/44

4m

Install RE+4/1 cables, 5d
mCC-2-PP
RTechs, 13/13 d

RPC Gas PP displacement YB-2
ZEC 1/2 w

5m



Crane

Cryo.	<input type="checkbox"/>	EL power	<input type="checkbox"/>	Water cool.	<input type="checkbox"/>	Database	<input type="checkbox"/>	
IT	<input type="checkbox"/>	Magnet	<input type="checkbox"/>	C6F14	<input type="checkbox"/>	Gas	<input type="checkbox"/>	
SL.	0	GEM	ECAL	ZEC	DT+ RB	Survey	TE-VSC	GS Dept
CP.	0	TOTEM	CMX	CSC RE	TK PIX	HCAL	EN Dept	RP

PX56 Plug
CLOSED

2019

TX54 Plug
CLOSED

September – Week 38

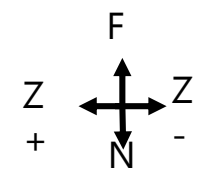

- Reinstall RE+4 SM, 4d
CRANE+ (Mon-Thu) 6/6 d
- Cable RE+4 SM, 3d
(Tue-Thu) 3/6 d
- 1. Move YE2 disk towards YE+1
2. Move YE3 disk towards YE+4
Leave 3.7m gap YE+2/YE+3
Leave ~2m gap YE+3/YE+4
(Fri) 1 d

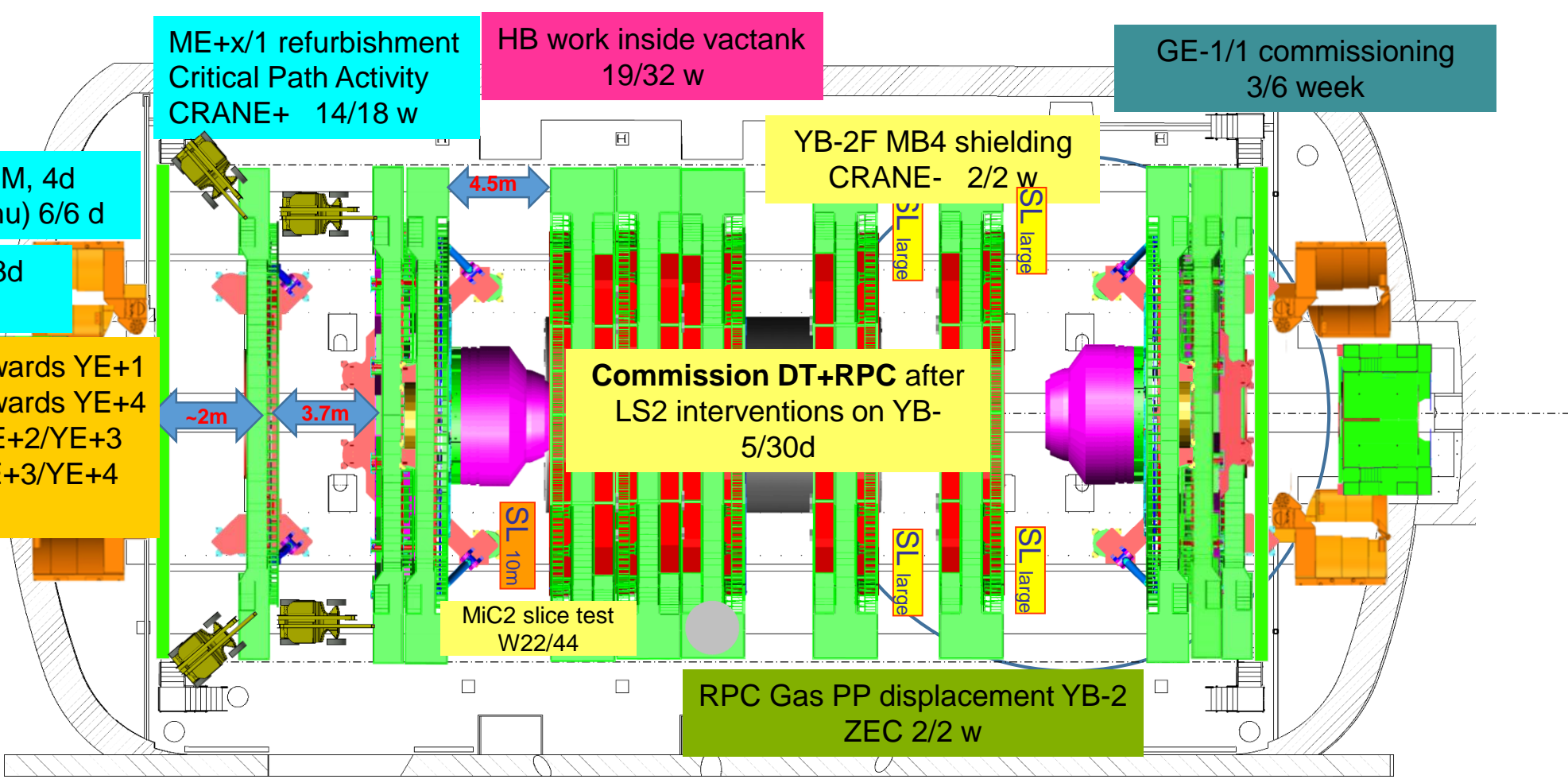

5m



Crane

Cryo.	█	EL power	█	Water cool.	█	Database	█								
IT	█	Magnet	█	C6F14	█	Gas	█								
SL.	0	GEM	█	ECAL	█	ZEC	█	DT+ RB	█	Survey	█	TE-VSC	█	GS Dept	█
CP.	0	TOTEM	█	CMX	█	CSC RE	█	TK PIX	█	HCAL	█	EN Dept	█	RP	█

PX56 Plug
CLOSED

TX54 Plug
CLOSED

2019

September – Week 39

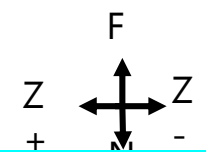

- Install 9 BACK ME+3/1, 2d
CRANE+ (Mon-Tue) 2/2 d
- Cabling & Connectivity
9 BACK ME+3/1, 3d
(Wed-Fri) 3/4 d
- Cable RE+4 SM, 3d
(Mon-Wed) 6/6 d
- Commission RE+4 SM, 2d
(Thu-Fri) 2/8 d
- Install ME+4/2 ALCT
mezzanine, 2d
(Wed-Thu) 2/2 d
- Commission ME+4/2
ALCT mezzanine, 1d
(Fri) 1/2 d

ME+x/1 refurbishment
Critical Path Activity
CRANE+ 15/18 w

HB work inside vactank
20/32 w

GE-1/1 commissioning
4/6 week

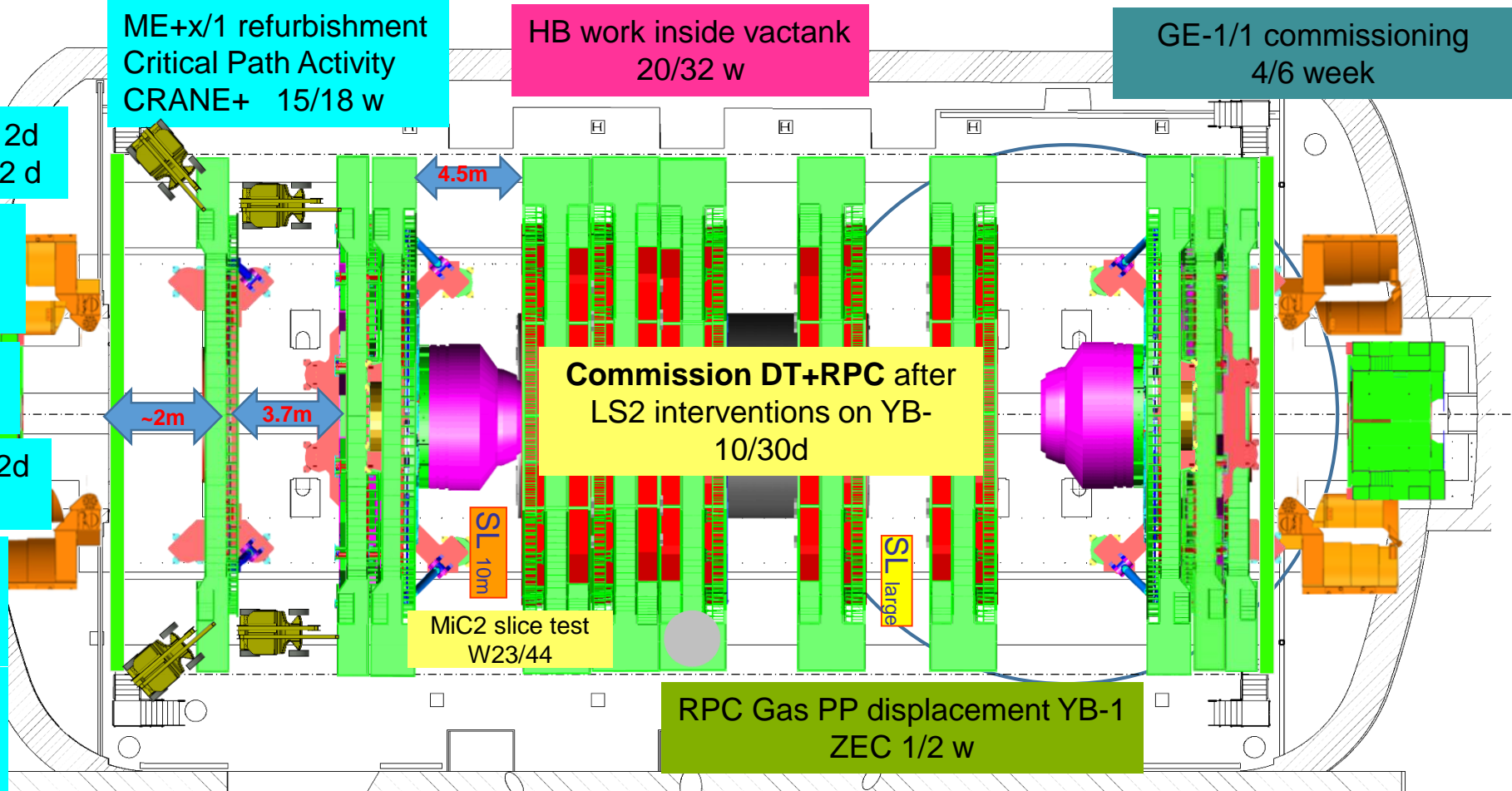

5m



Cryo.	█	EL power	█	Water cool.	█	Database	█								
IT	█	Magnet	█	C6F14	█	Gas	█								
SL.	0	GEM	█	ECAL	█	ZEC	█	DT+ RB	█	Survey	█	TE-VSC	█	GS Dept	█
CP.	0	TOTEM	█	CMX	█	CSC RE	█	TK PIX	█	HCAL	█	EN Dept	█	RP	█

PX56 Plug CLOSED	2019
TX54 Plug CLOSED	September – Week 40

Crane

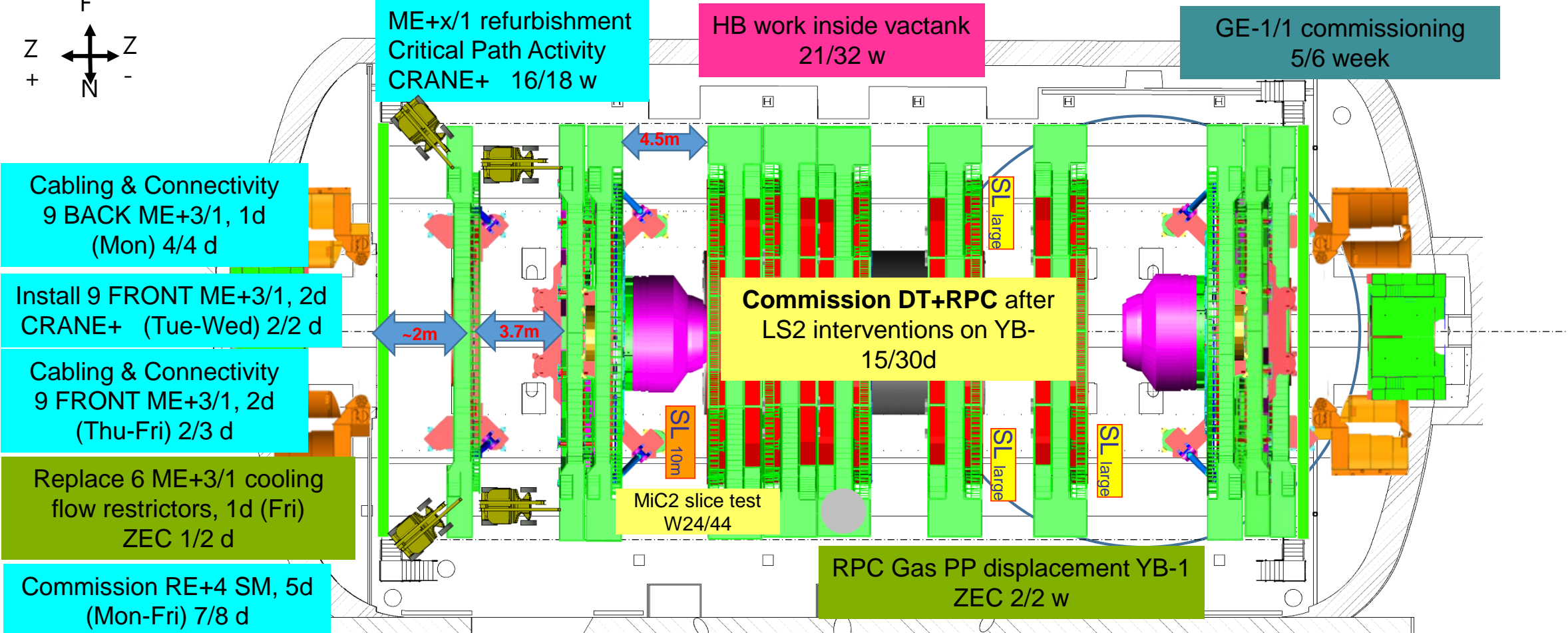
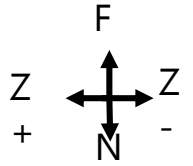

5m



Crane

Cryo.	█	EL power	█	Water cool.	█	Database	█
IT	█	Magnet	█	C6F14	█	Gas	█
SL. 0	GEM	ECAL	ZEC	DT+ RB	Survey	TE-VSC	GS Dept
CP. 0	TOTEM	CMX	CSC RE	TK PIX	HCAL	EN Dept	RP

PX56 Plug CLOSED	2019
TX54 Plug CLOSED	October – Week 41

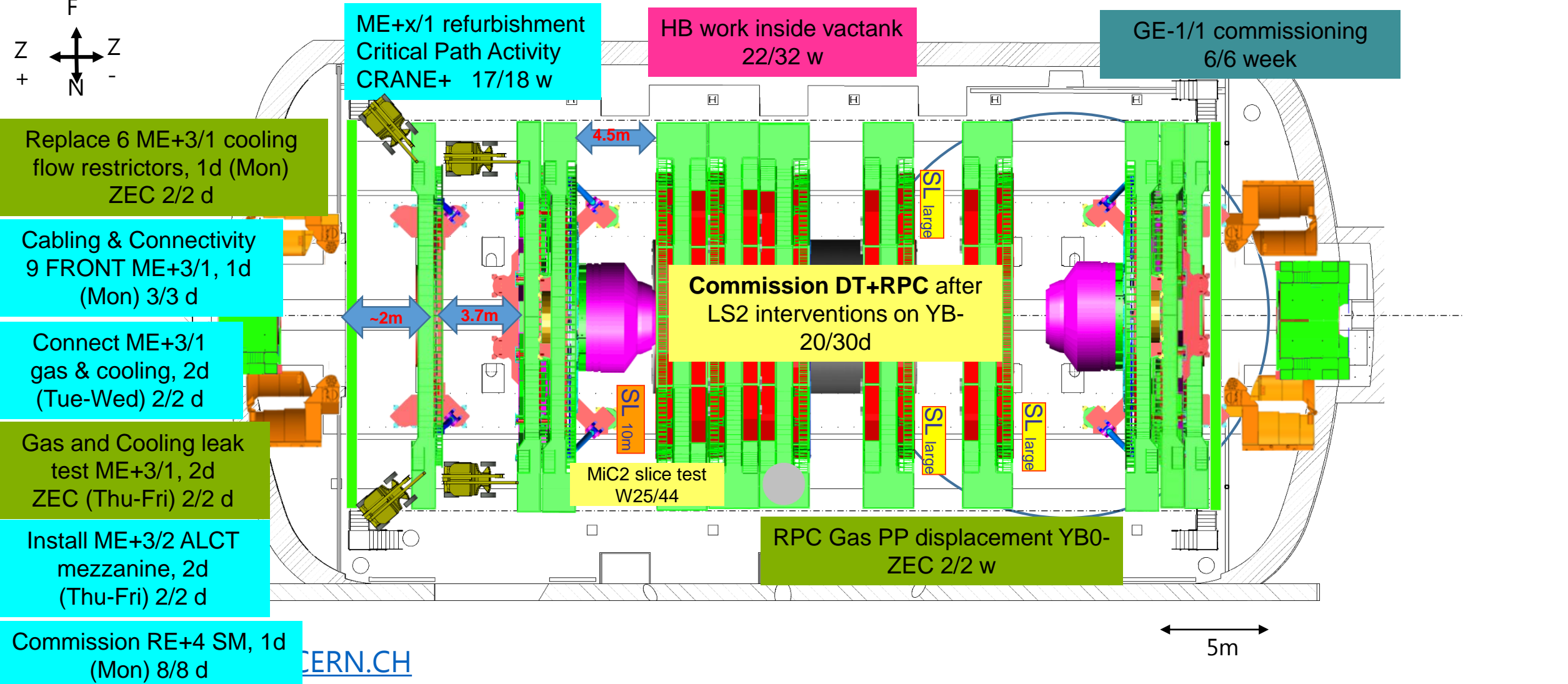
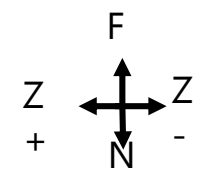

Replace 6 ME+3/1 cooling flow restrictors, 1d (Mon)
ZEC 2/2 d

Cabling & Connectivity 9 FRONT ME+3/1, 1d (Mon) 3/3 d

Connect ME+3/1 gas & cooling, 2d (Tue-Wed) 2/2 d

Gas and Cooling leak test ME+3/1, 2d ZEC (Thu-Fri) 2/2 d

Install ME+3/2 ALCT mezzanine, 2d (Thu-Fri) 2/2 d

Commission RE+4 SM, 1d (Mon) 8/8 d

ME+x/1 refurbishment
Critical Path Activity
CRANE+ 17/18 w

HB work inside vactank
22/32 w

GE-1/1 commissioning
6/6 week

Commission DT+RPC after
LS2 interventions on YB-
20/30d

MiC2 slice test
W25/44

RPC Gas PP displacement YB0-
ZEC 2/2 w

CERN.CH

5m

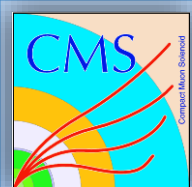

Crane

Cryo.	<input type="checkbox"/>	EL power	<input type="checkbox"/>	Water cool.	<input type="checkbox"/>	Database	<input type="checkbox"/>	
IT	<input type="checkbox"/>	Magnet	<input type="checkbox"/>	C6F14	<input type="checkbox"/>	Gas	<input type="checkbox"/>	
SL.	0	GEM	ECAL	ZEC	DT+ RB	Survey	TE-VSC	GS Dept
CP.	0	TOTEM	CMX	CSC RE	TK PIX	HCAL	EN Dept	RP

PX56 Plug
CLOSED

TX54 Plug
CLOSED

2019

October – Week 42

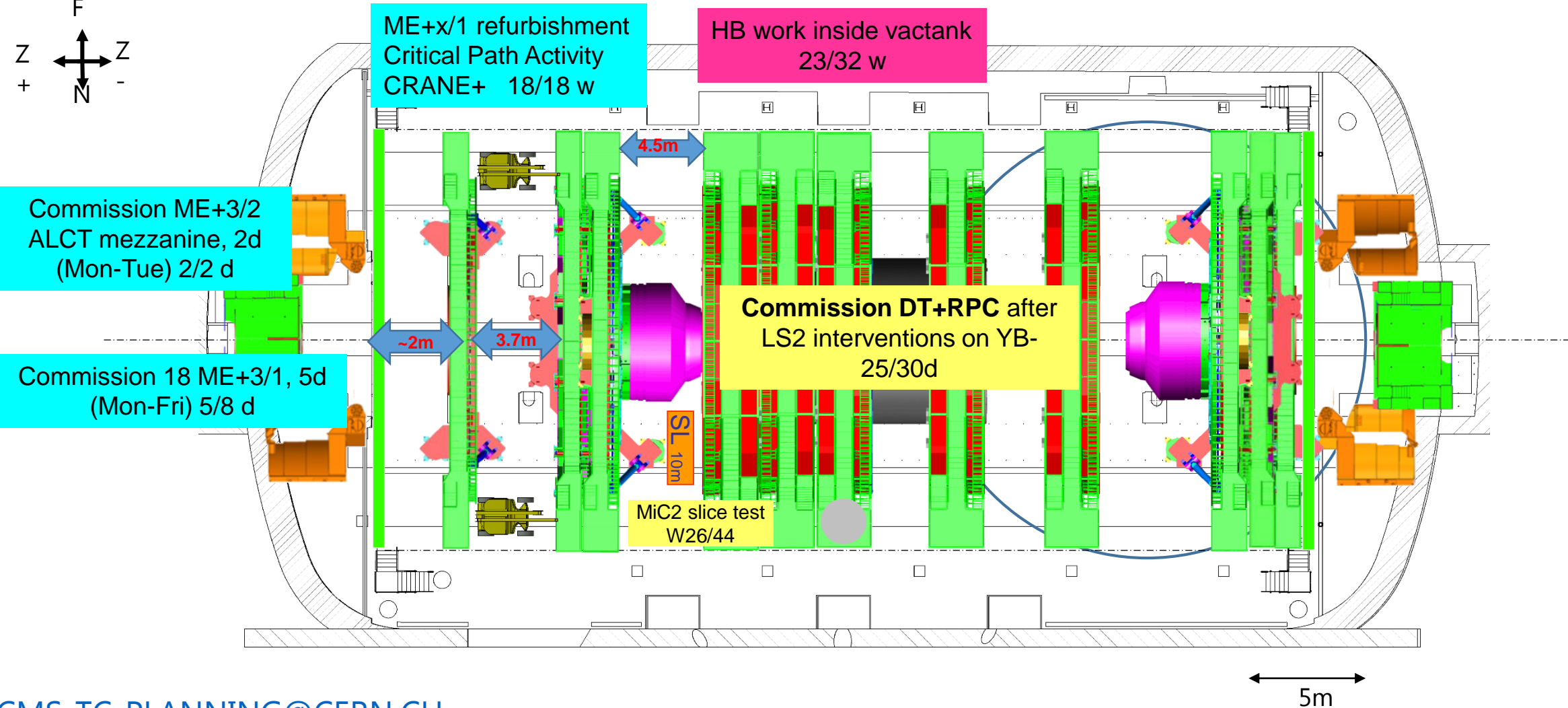
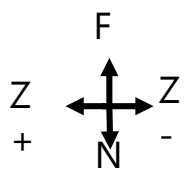



Crane

Cryo.	█	EL power	█	Water cool.	█	Database	█
IT	█	Magnet	█	C6F14	█	Gas	█
SL. 0	GEM	ECAL	ZEC	DT+ RB	Survey	TE-VSC	GS Dept
CP. 0	TOTEM	CMX	CSC RE	TK PIX	HCAL	EN Dept	RP

PX56 Plug
CLOSED

TX54 Plug
CLOSED

2019

October – Week 43

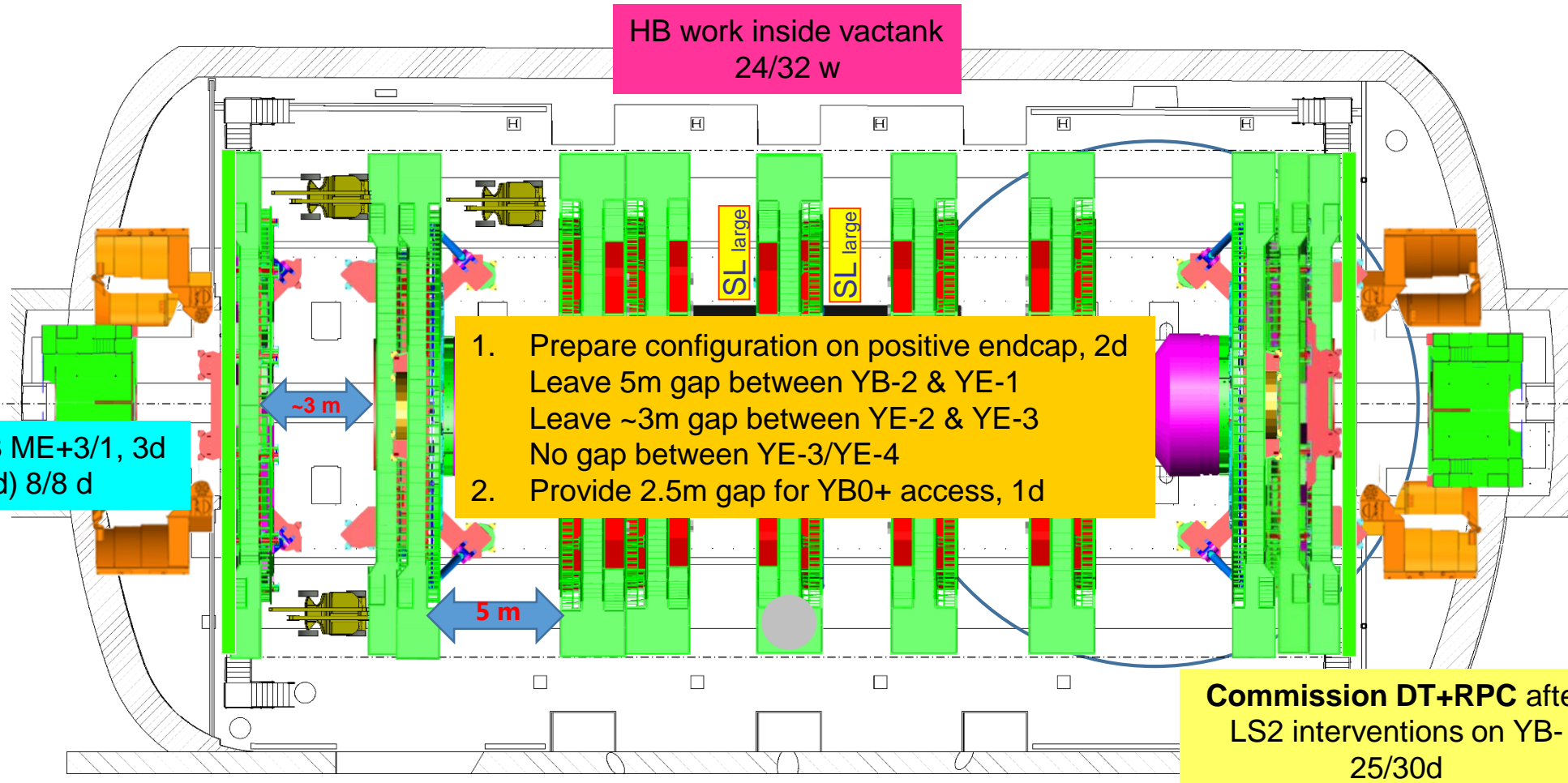
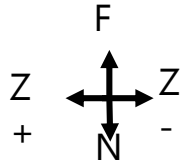

Commission 18 ME+3/1, 3d
(Mon-Wed) 8/8 d

Commission DT+RPC after
LS2 interventions on YB-
25/30d

5m



Crane

Cryo.	█	EL power	█	Water cool.	█	Database	█
IT	█	Magnet	█	C6F14	█	Gas	█
SL. 0	GEM	ECAL	ZEC	DT+ RB	Survey	TE-VSC	GS Dept
CP. 0	TOTEM	CMX	CSC RE	TK PIX	HCAL	EN Dept	RP

PX56 Plug CLOSED

2019

TX54 Plug CLOSED

October – Week 44

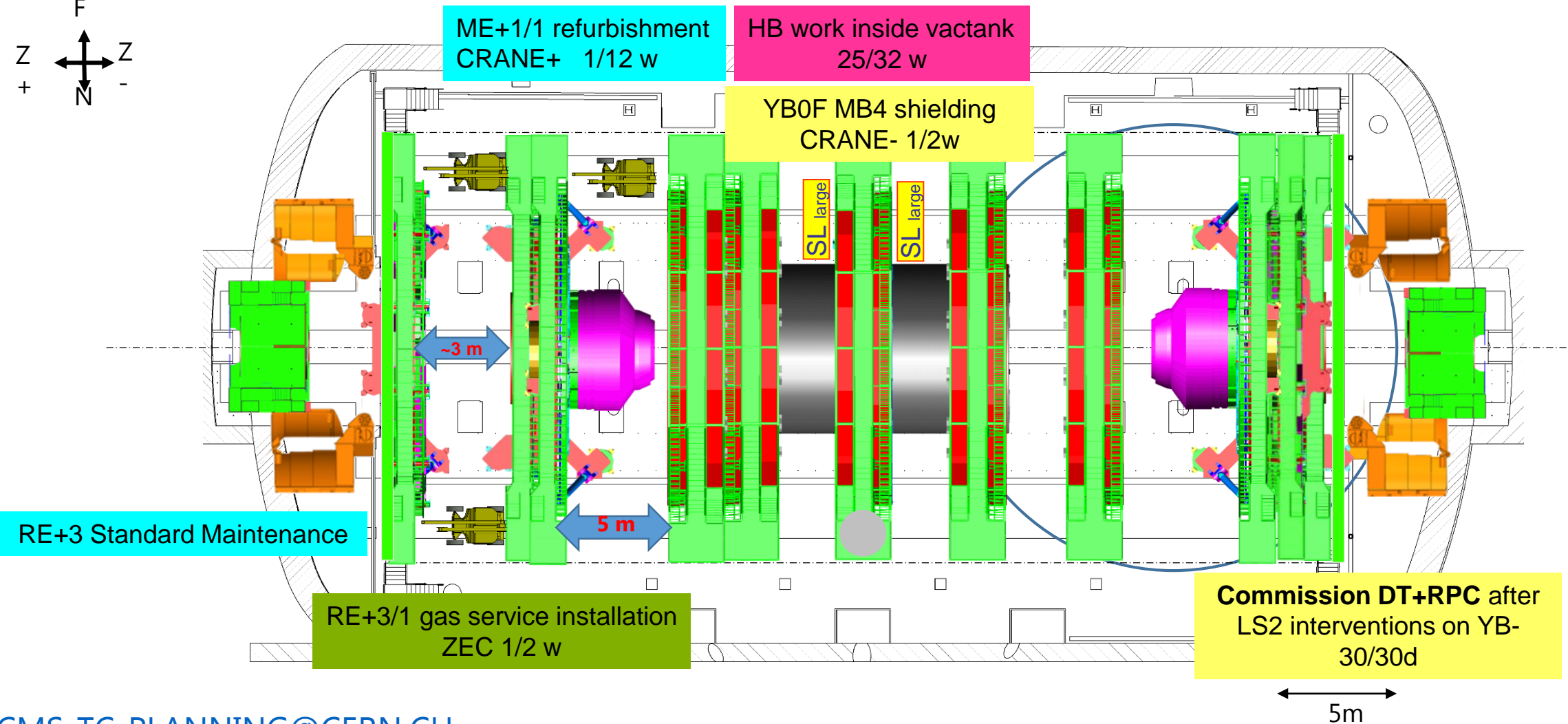
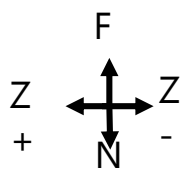



Crane

Cryo.	█	EL power	█	Water cool.	█	Database	█
IT	█	Magnet	█	C6F14	█	Gas	█
SL. 0	GEM	ECAL	ZEC	DT+ RB	Survey	TE-VSC	GS Dept
CP. 0	TOTEM	CMX	CSC RE	TK PIX	HCAL	EN Dept	RP

PX56 Plug CLOSED
TX54 Plug CLOSED

2019
November – Week 45

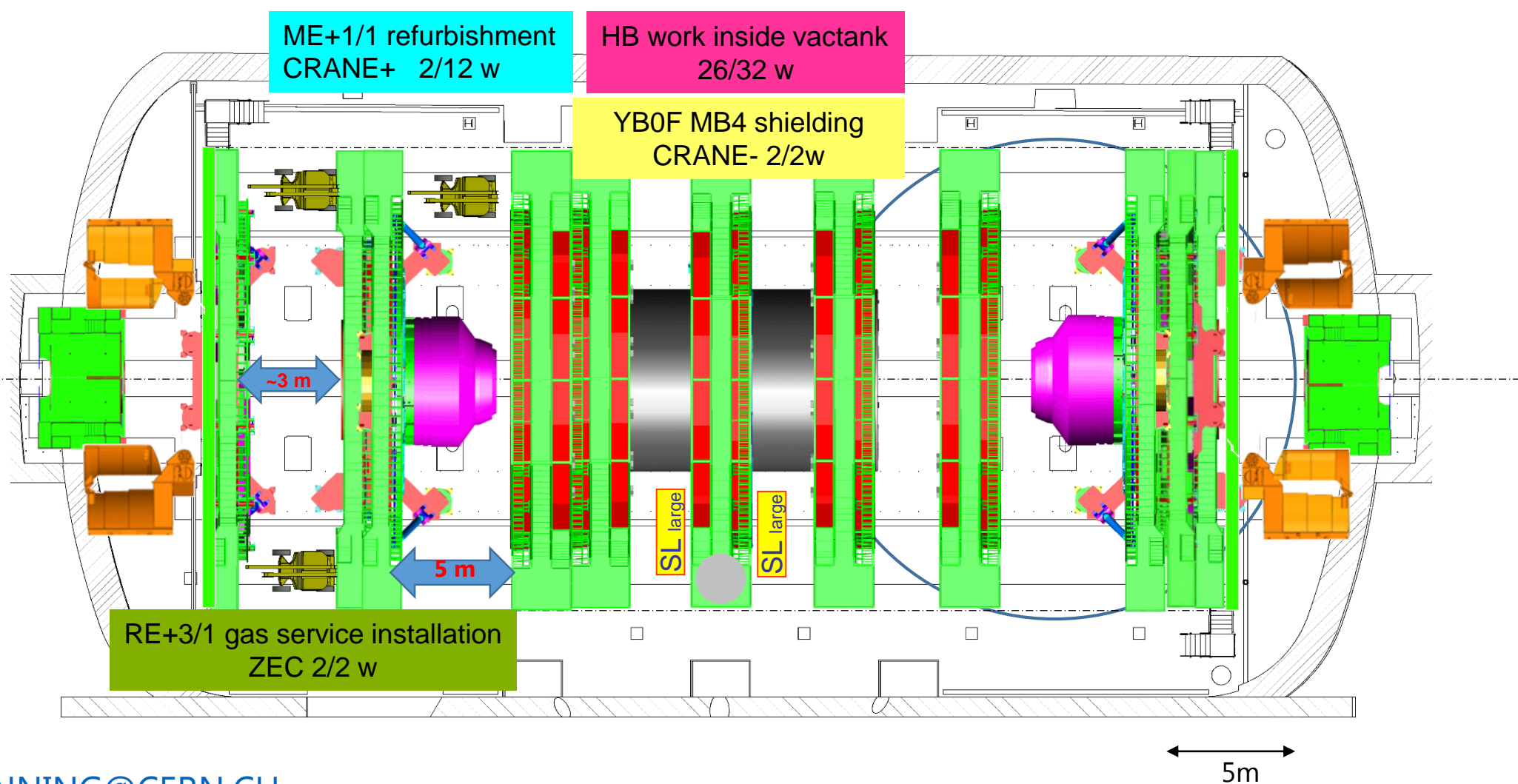
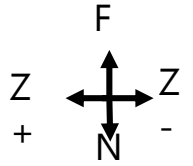



Crane

Cryo.	█	EL power	█	Water cool.	█	Database	█
IT	█	Magnet	█	C6F14	█	Gas	█
SL. 0	GEM	ECAL	ZEC	DT+ RB	Survey	TE-VSC	GS Dept
CP. 0	TOTEM	CMX	CSC RE	TK PIX	HCAL	EN Dept	RP

PX56 Plug
CLOSED

2019

TX54 Plug
CLOSED

November – Week 46

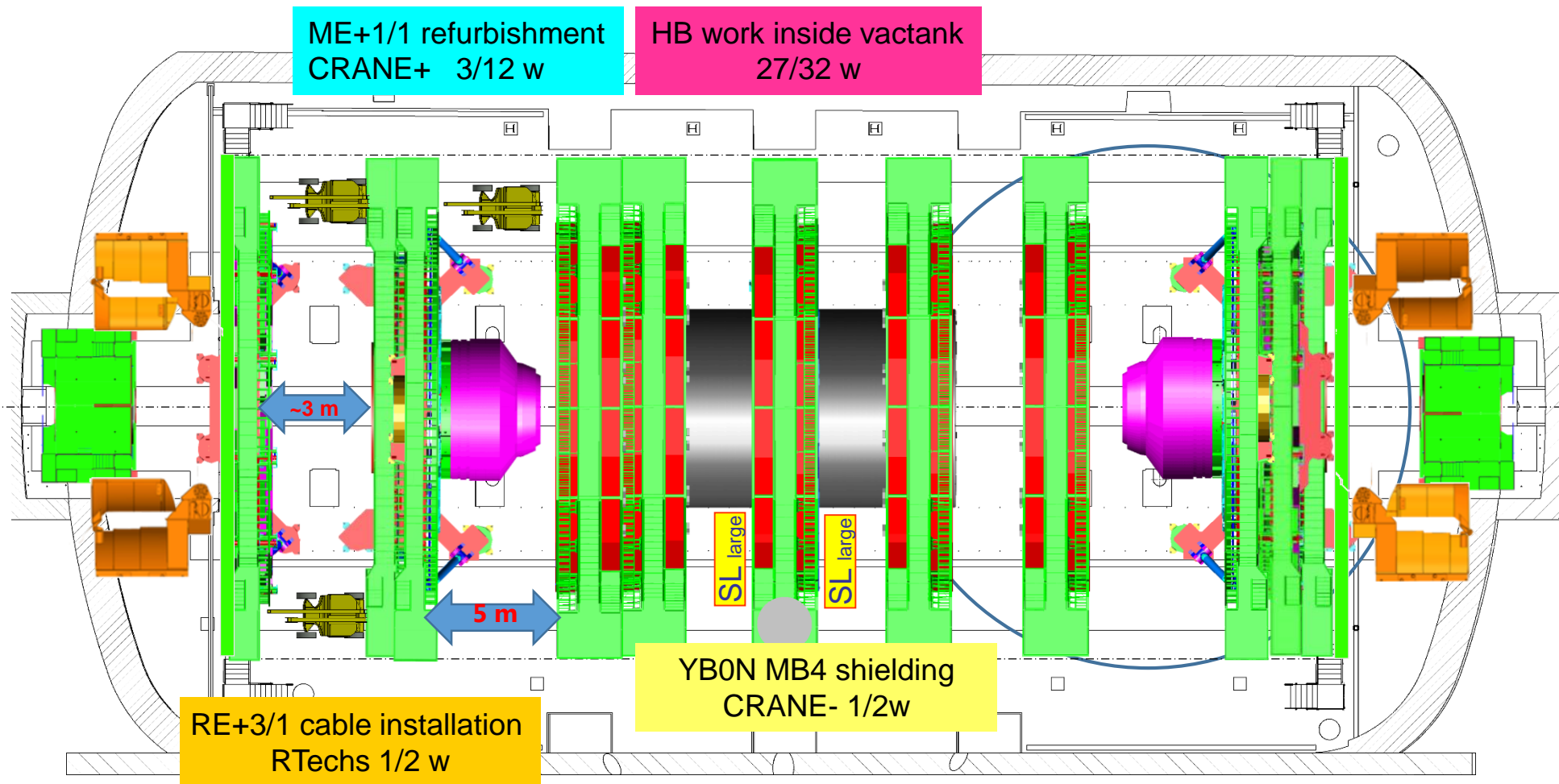
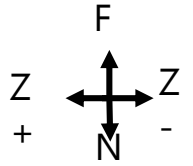

5m



Crane

Cryo.	█	EL power	█	Water cool.	█	Database	█
IT	█	Magnet	█	C6F14	█	Gas	█
SL. 0	GEM	ECAL	ZEC	DT+ RB	Survey	TE-VSC	GS Dept
CP. 0	TOTEM	CMX	CSC RE	TK PIX	HCAL	EN Dept	RP

PX56 Plug
CLOSED

2019

TX54 Plug
CLOSED

November – Week 47

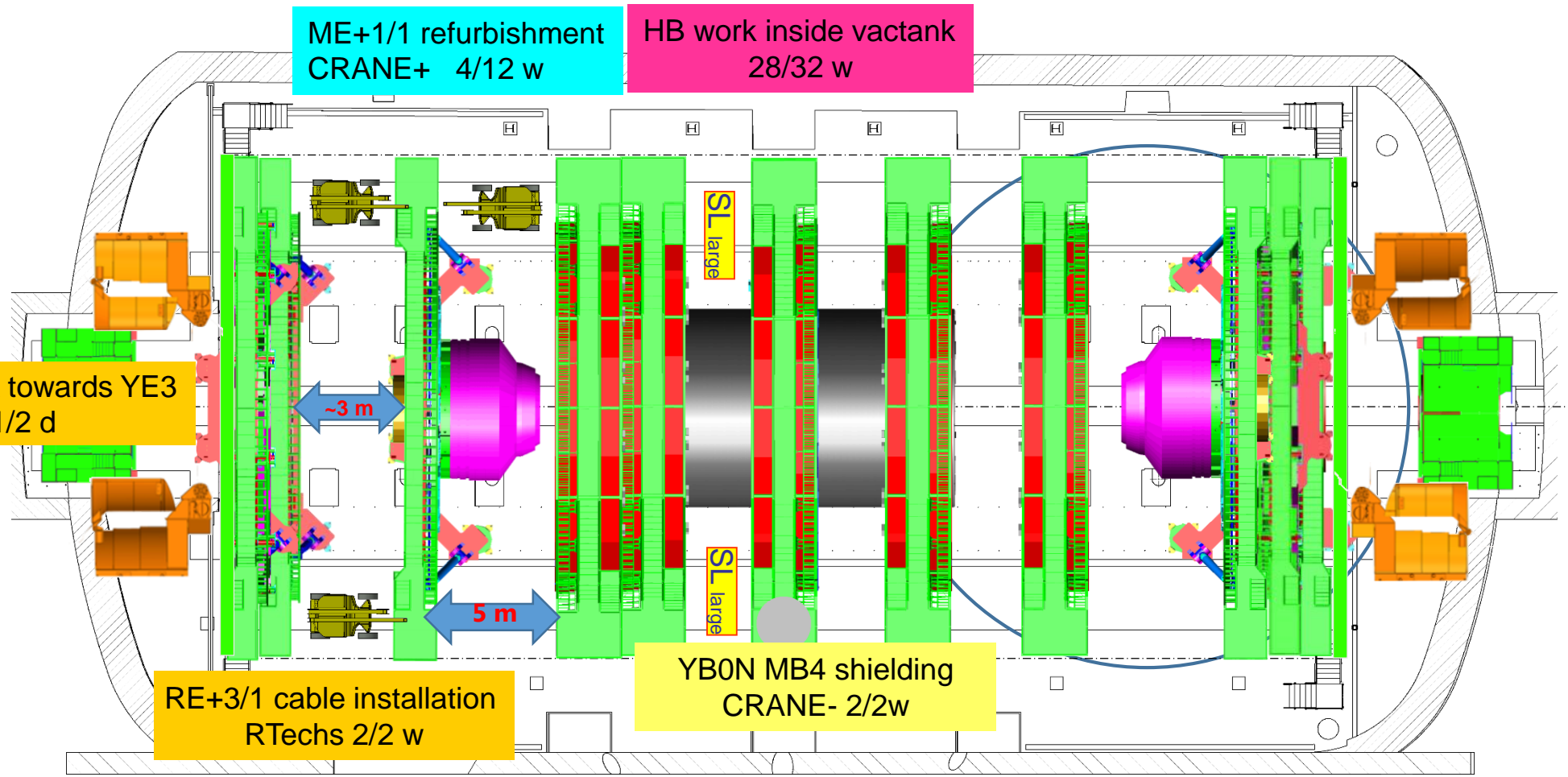
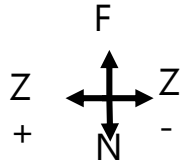

Move YE+2 disk towards YE3
(Mon) 1/2 d

5m



Crane

Cryo.	<input type="checkbox"/>	EL power	<input type="checkbox"/>	Water cool.	<input type="checkbox"/>	Database	<input type="checkbox"/>	
IT	<input type="checkbox"/>	Magnet	<input type="checkbox"/>	C6F14	<input type="checkbox"/>	Gas	<input type="checkbox"/>	
SL.	0	GEM	ECAL	ZEC	DT+ RB	Survey	TE-VSC	GS Dept
CP.	0	TOTEM	CMX	CSC RE	TK PIX	HCAL	EN Dept	RP

PX56 Plug
CLOSED

TX54 Plug
CLOSED

2019

November – Week 48

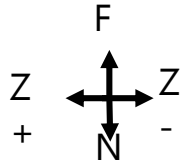

GE+2/1 gas service installation, 5d
ZEC 1/2 w

ME+1/1 refurbishment
CRANE+ 5/12 w

HB work inside vactank
29/32 w

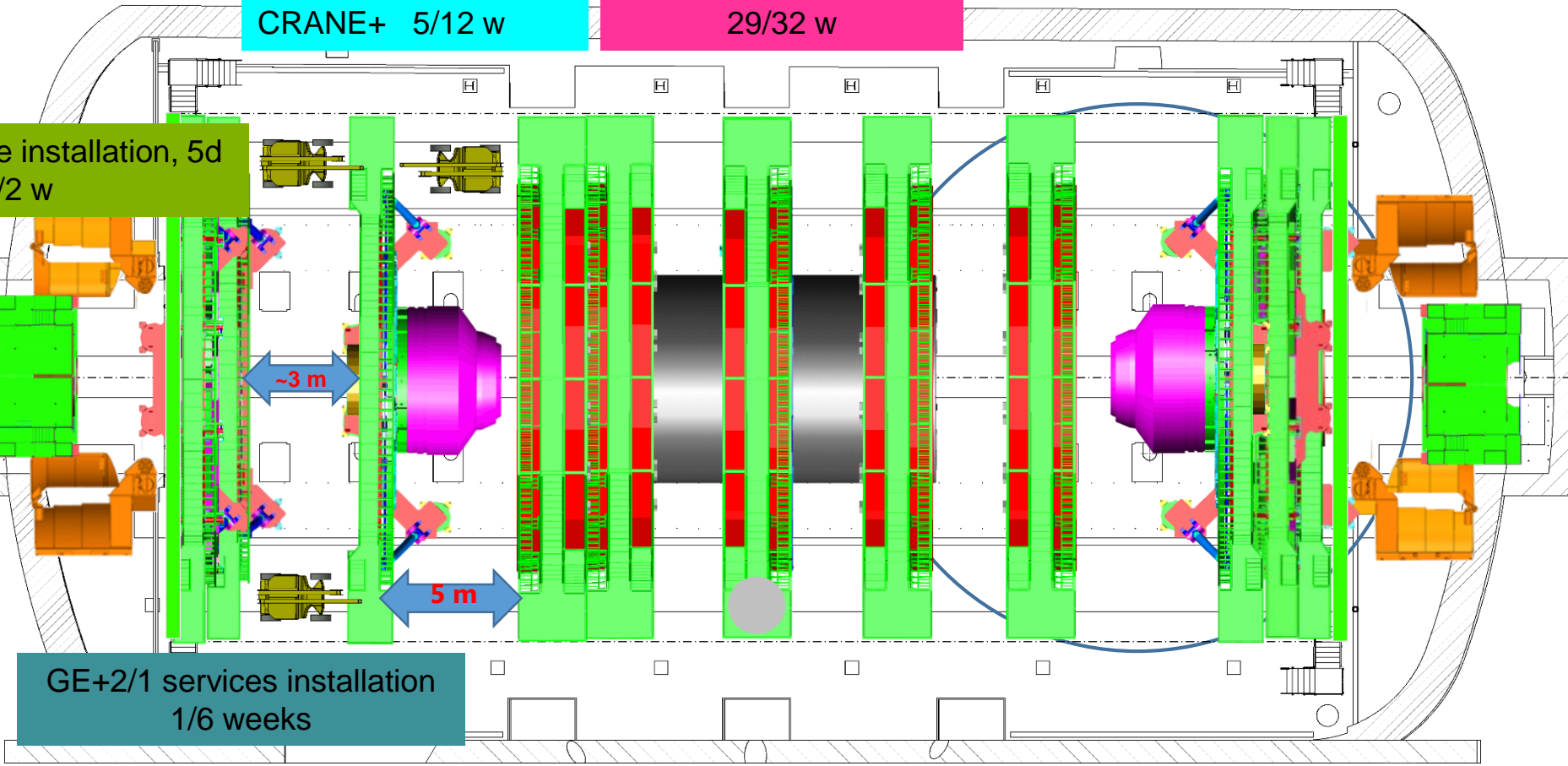

GE+2/1 services installation
1/6 weeks

5m



Crane

Cryo.	<input type="checkbox"/>	EL power	<input type="checkbox"/>	Water cool.	<input type="checkbox"/>	Database	<input type="checkbox"/>	
IT	<input type="checkbox"/>	Magnet	<input type="checkbox"/>	C6F14	<input type="checkbox"/>	Gas	<input type="checkbox"/>	
SL.	0	GEM	ECAL	ZEC	DT+ RB	Survey	TE-VSC	GS Dept
CP.	0	TOTEM	CMX	CSC RE	TK PIX	HCAL	EN Dept	RP

PX56 Plug
CLOSED

2019

TX54 Plug
CLOSED

December – Week 49

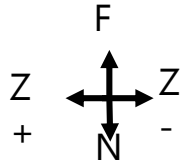

ME+1/1 refurbishment
CRANE+ 6/12 w

HB work inside vactank
30/32 w

GE+2/1 gas service installation, 5d
ZEC 2/2 w

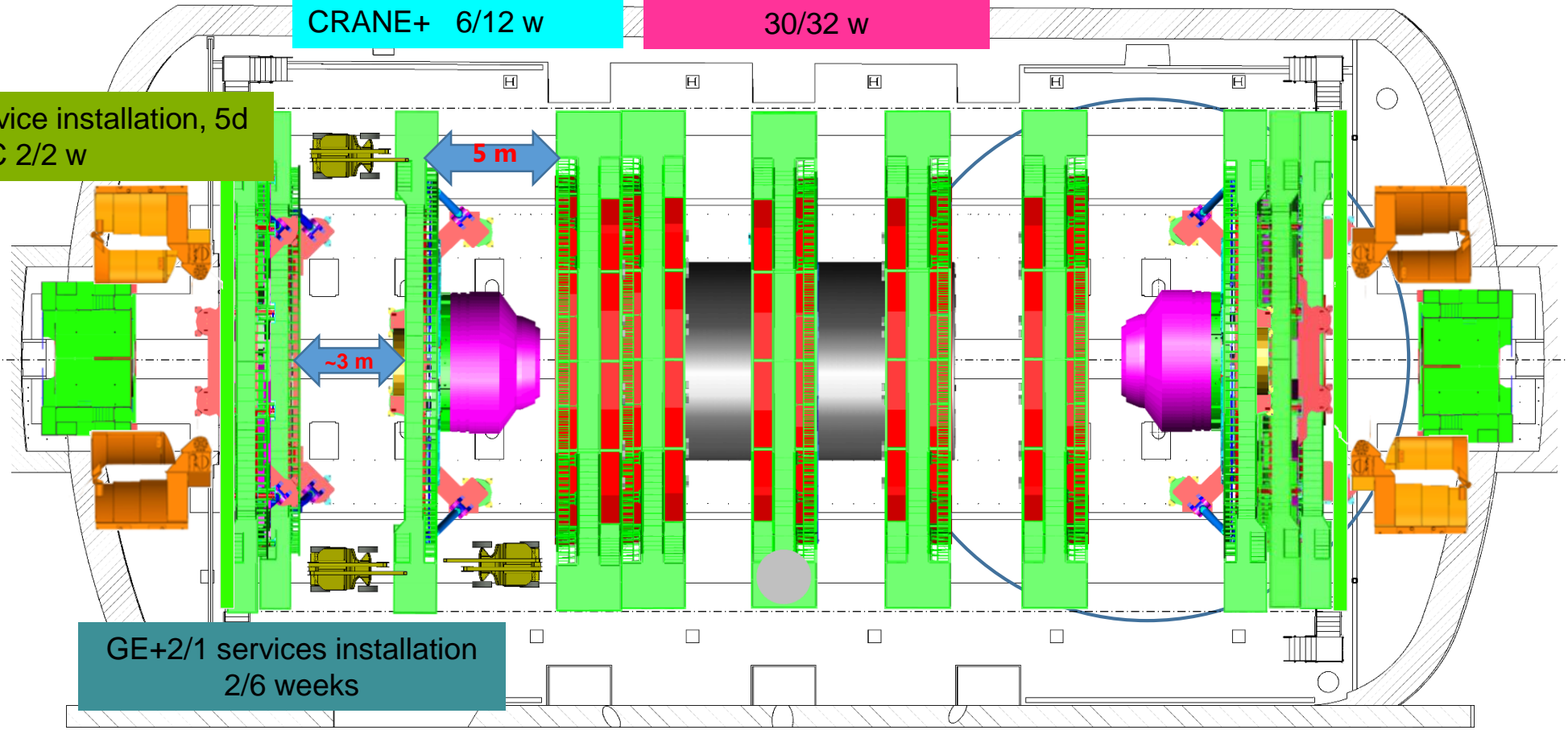

GE+2/1 services installation
2/6 weeks

5m



Crane

Cryo.	█	EL power	█	Water cool.	█	Database	█
IT	█	Magnet	█	C6F14	█	Gas	█
SL. 0	GEM	ECAL	ZEC	DT+ RB	Survey	TE-VSC	GS Dept
CP. 0	TOTEM	CMX	CSC RE	TK PIX	HCAL	EN Dept	RP

PX56 Plug
CLOSED

2019

TX54 Plug
CLOSED

December – Week 50

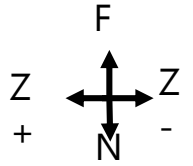

ME+1/1 refurbishment
CRANE+ 7/12 w

HB work inside vactank
31/32 w

GE+2/1 cooling system installation, 5d
ZEC 1/1 w

GE+2/1 services installation
3/6 weeks

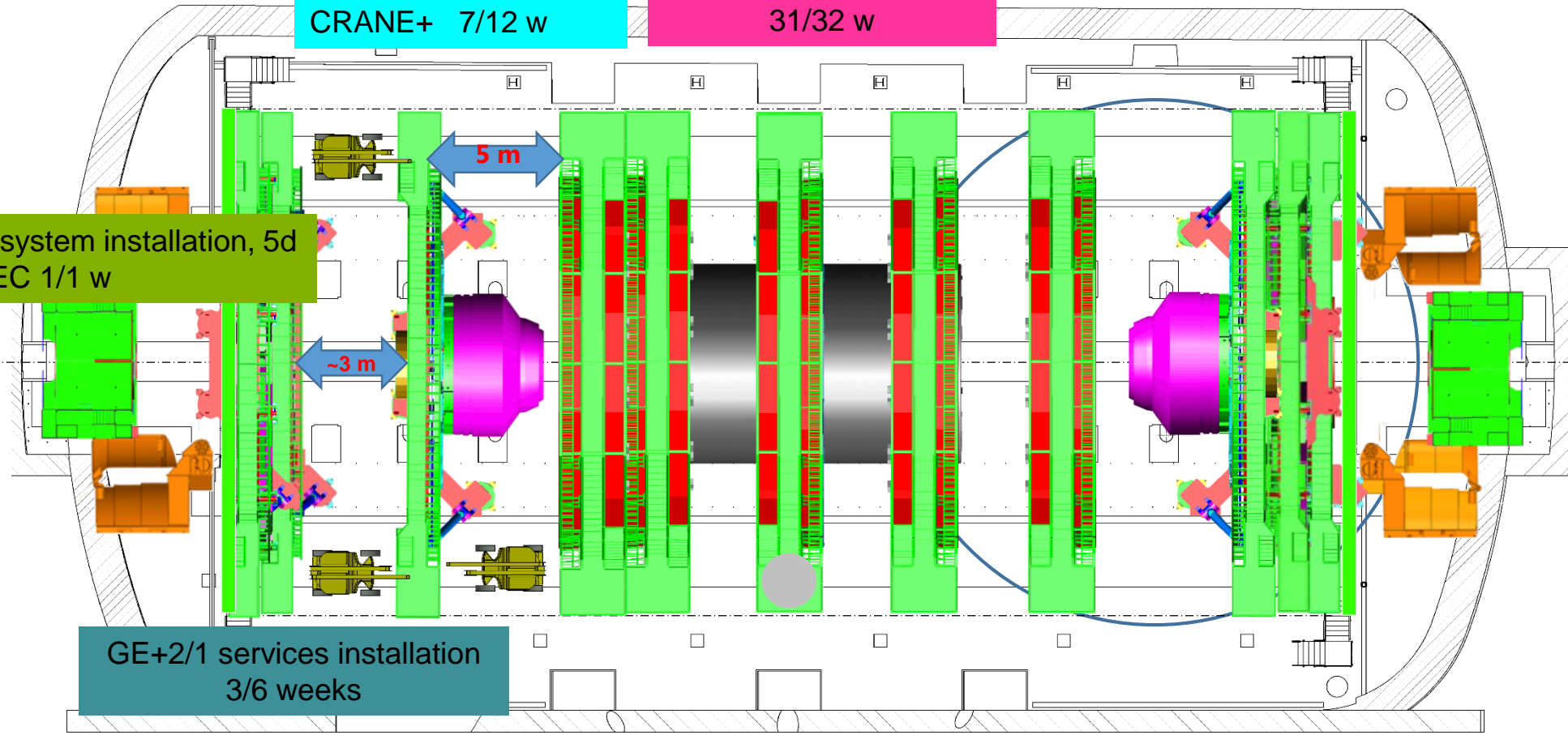

5m



Crane

Cryo.	█	EL power	█	Water cool.	█	Database	█
IT	█	Magnet	█	C6F14	█	Gas	█
SL. 0	GEM	ECAL	ZEC	DT+ RB	Survey	TE-VSC	GS Dept
CP. 0	TOTEM	CMX	CSC RE	TK PIX	HCAL	EN Dept	RP

PX56 Plug CLOSED
TX54 Plug CLOSED

2019
December – Week 51

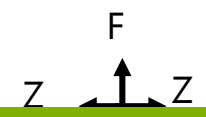

GE+2/1 gas leak test, 5d
ZEC 2pers. 1CP, 2/2 w

ME+1/1 refurbishment
CRANE+ 8/12 w

HB work inside vactank
32/32 w

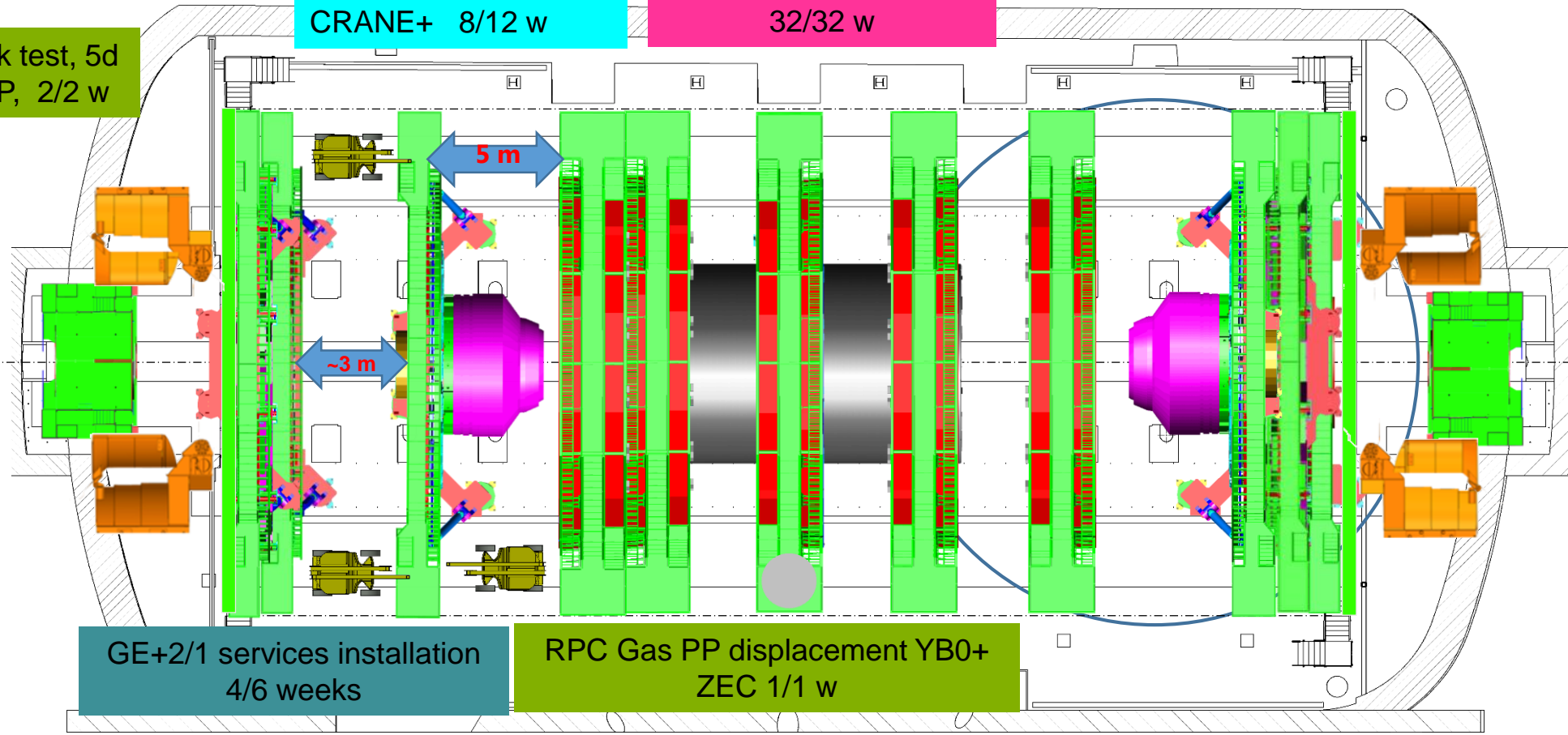

GE+2/1 services installation
4/6 weeks

RPC Gas PP displacement YB0+
ZEC 1/1 w

5m



Crane

Cryo.	<input type="checkbox"/>	EL power	<input type="checkbox"/>	Water cool.	<input type="checkbox"/>	Database	<input type="checkbox"/>	
IT	<input type="checkbox"/>	Magnet	<input type="checkbox"/>	C6F14	<input type="checkbox"/>	Gas	<input type="checkbox"/>	
SL.	0	GEM	ECAL	ZEC	DT+ RB	Survey	TE-VSC	GS Dept
CP.	0	TOTEM	CMX	CSC RE	TK PIX	HCAL	EN Dept	RP

PX56 Plug CLOSED
TX54 Plug CLOSED

2019
December – Week 52

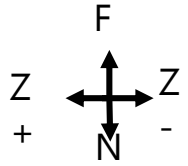

End of Year Lab Closure

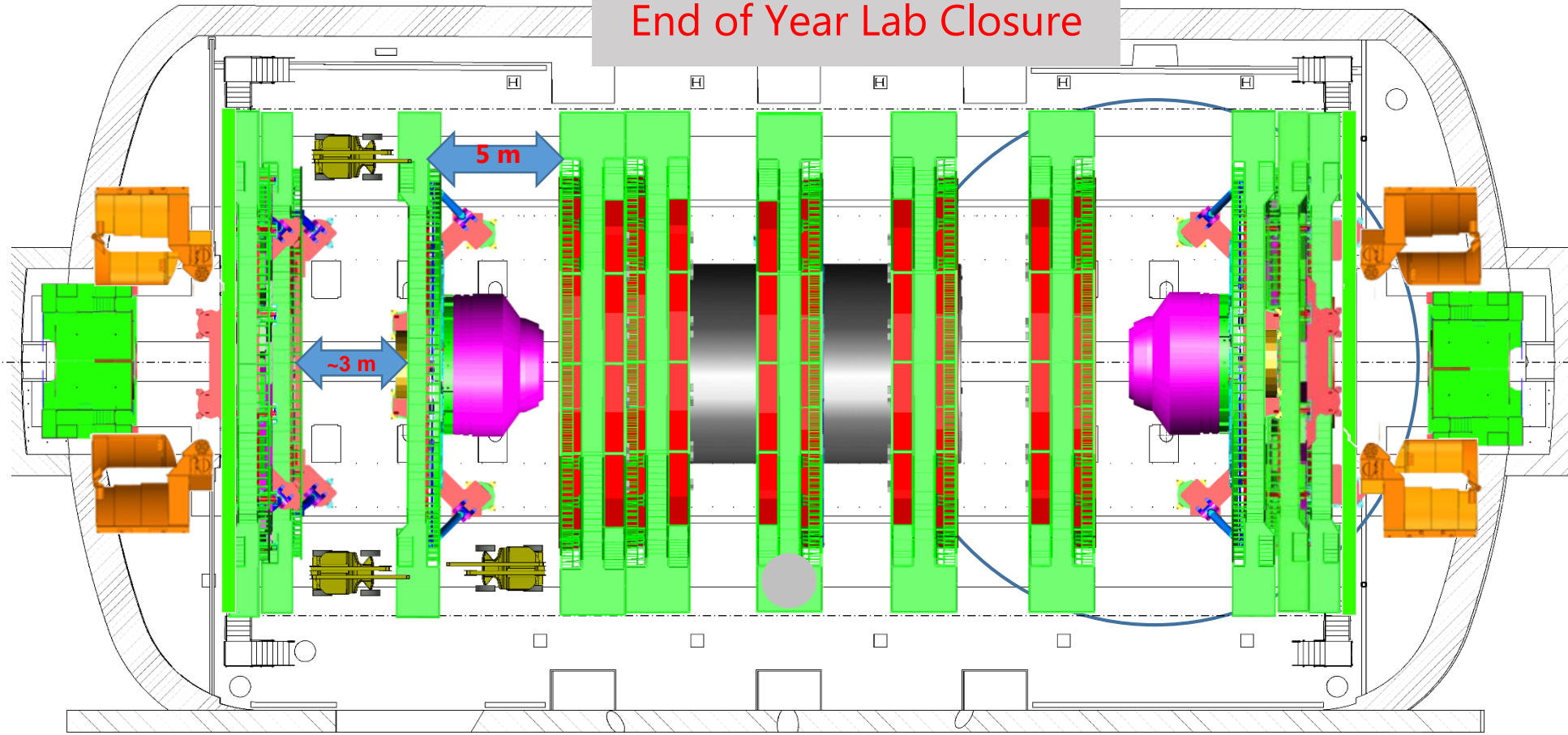

5m



Crane

Cryo.	█	EL power	█	Water cool.	█	Database	█
IT	█	Magnet	█	C6F14	█	Gas	█
SL. 0	GEM	ECAL	ZEC	DT+ RB	Survey	TE-VSC	GS Dept
CP. 0	TOTEM	CMX	CSC RE	TK PIX	HCAL	EN Dept	RP

PX56 Plug
CLOSED

TX54 Plug
CLOSED

2020

January – Week 1

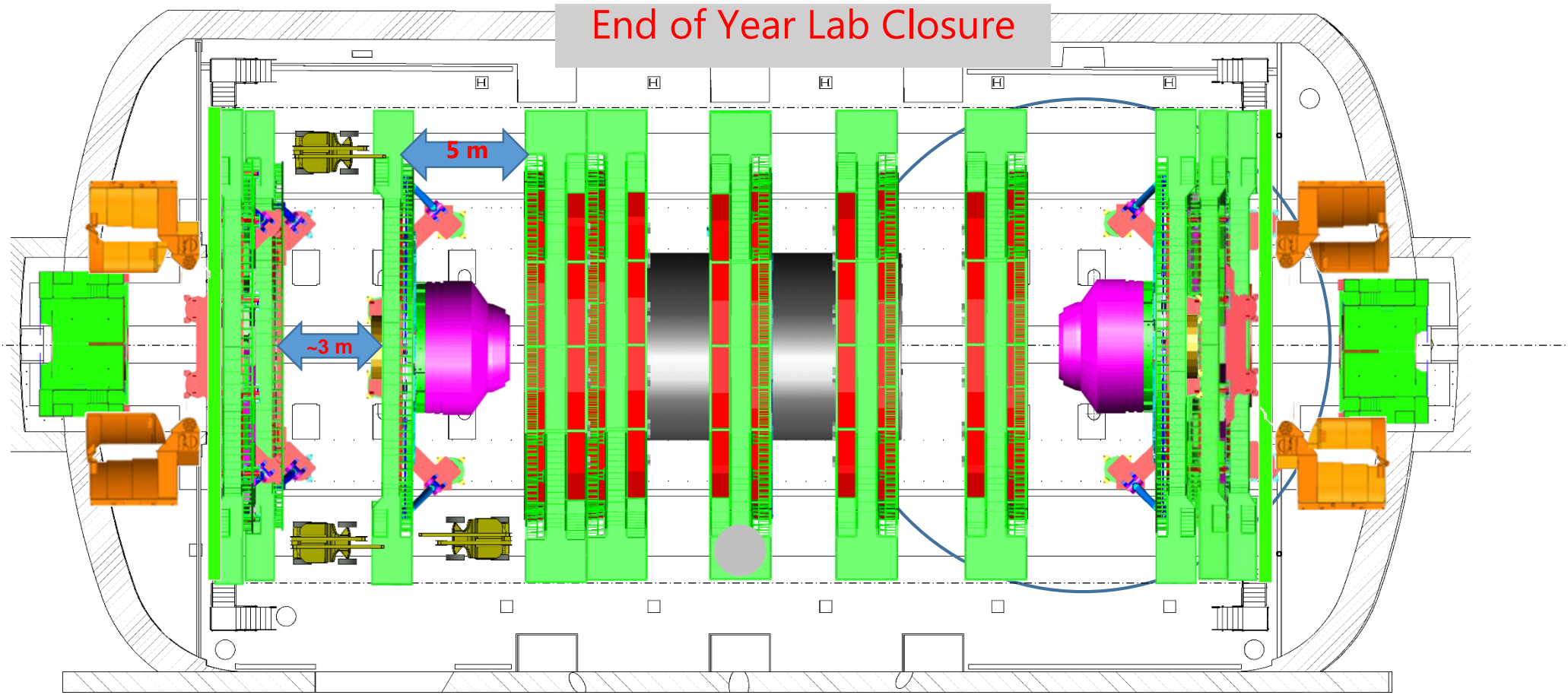
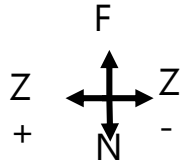



Crane

Cryo.	█	EL power	█	Water cool.	█	Database	█
IT	█	Magnet	█	C6F14	█	Gas	█
SL. 0	GEM	ECAL	ZEC	DT+ RB	Survey	TE-VSC	GS Dept
CP. 0	TOTEM	CMX	CSC RE	TK PIX	HCAL	EN Dept	RP

PX56 Plug
CLOSED

2020

TX54 Plug
CLOSED

January – Week 2

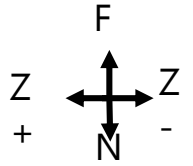

ME+1/1 refurbishment
CRANE+ 9/12 w

GE+2/1 cable installation, 5d
RTechs 1/2 w

GE+2/1 services installation
5/6 weeks

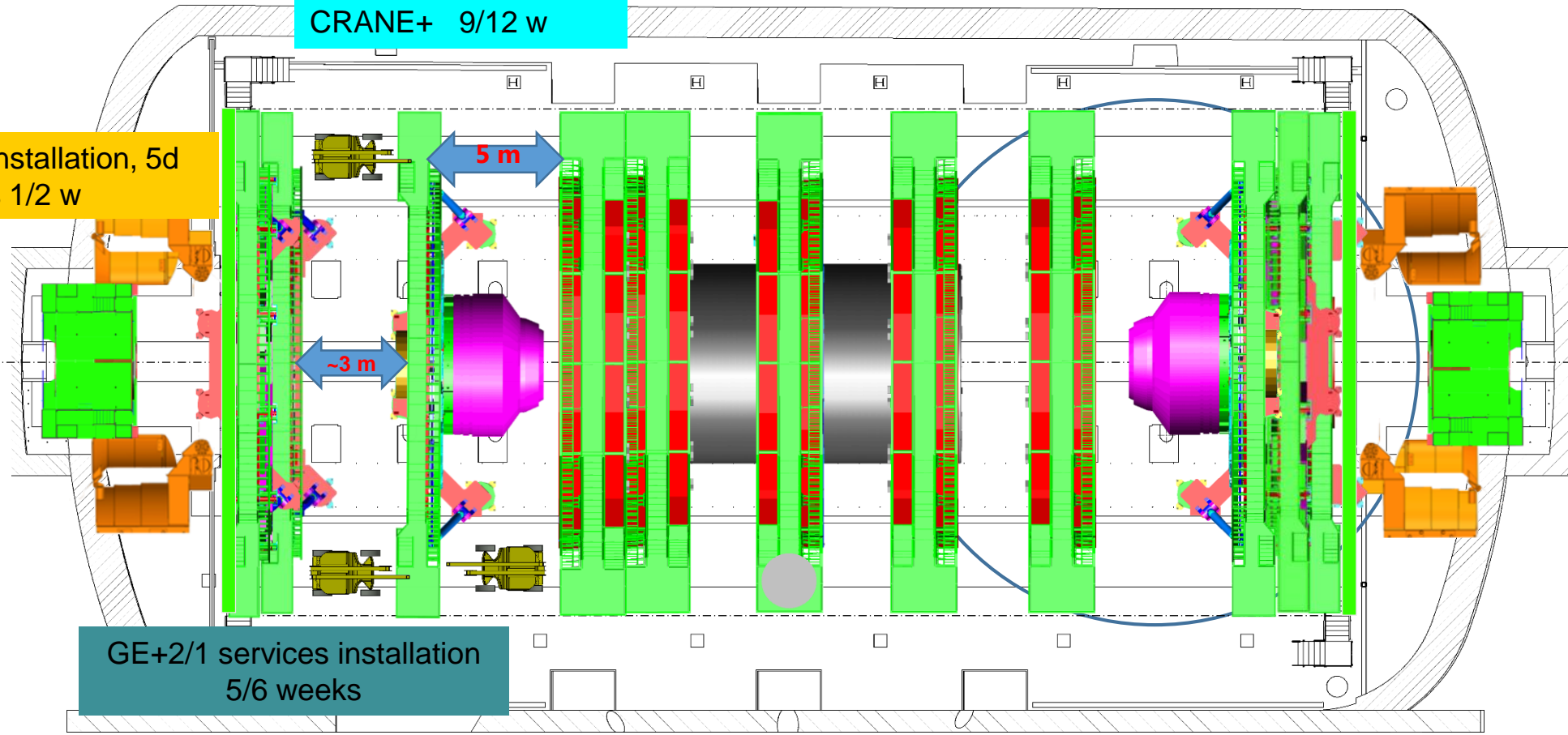

5m



Crane

Cryo.	█	EL power	█	Water cool.	█	Database	█
IT	█	Magnet	█	C6F14	█	Gas	█
SL. 0	GEM	ECAL	ZEC	DT+ RB	Survey	TE-VSC	GS Dept
CP. 0	TOTEM	CMX	CSC RE	TK PIX	HCAL	EN Dept	RP

PX56 Plug
CLOSED

TX54 Plug
CLOSED

2020

January – Week 3

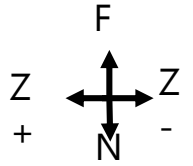

GE+2/1 cable installation, 5d
RTechs 2/2 w

ME+1/1 refurbishment
CRANE+ 10/12 w

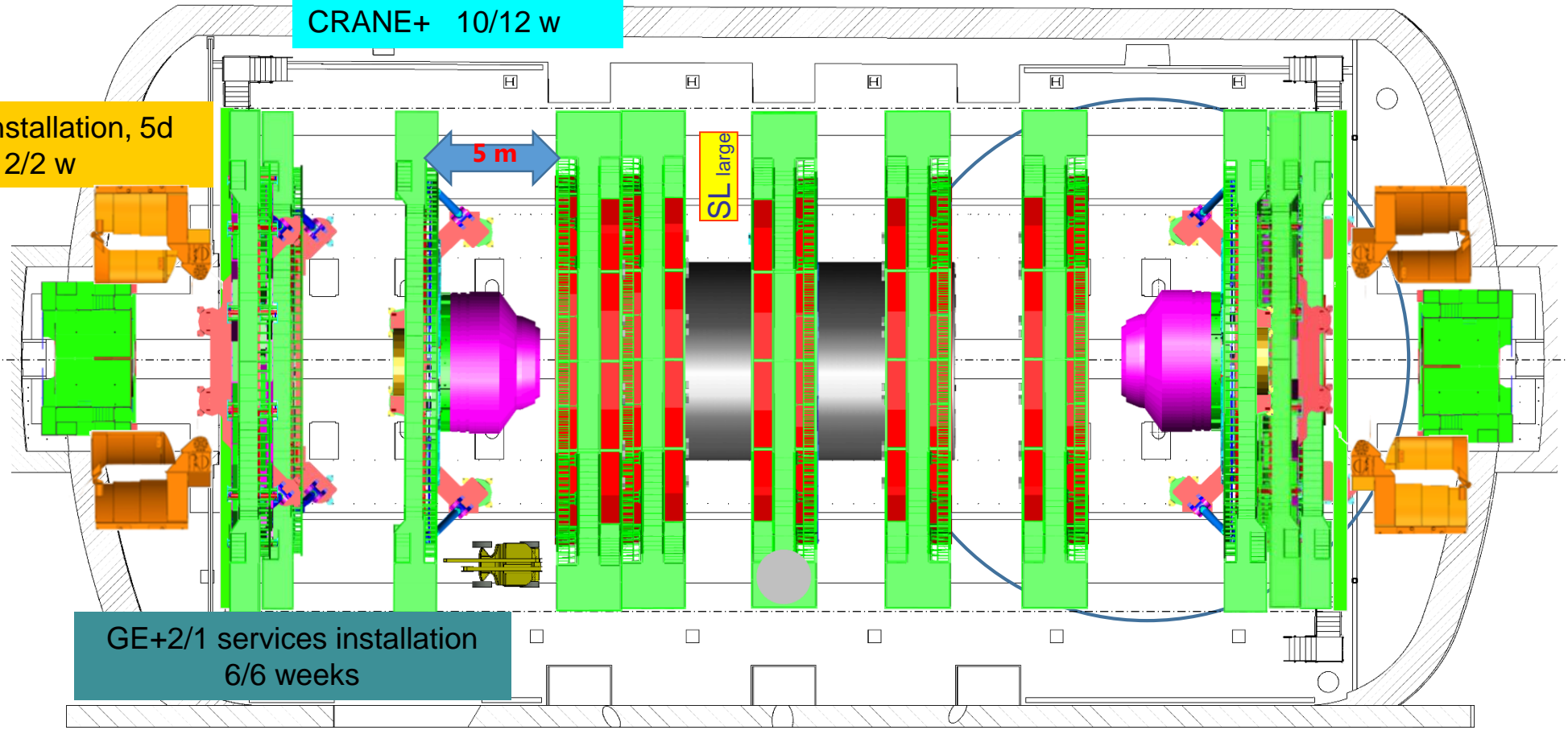

GE+2/1 services installation
6/6 weeks

5m



Crane

Cryo.	█	EL power	█	Water cool.	█	Database	█
IT	█	Magnet	█	C6F14	█	Gas	█
SL. 0	GEM	ECAL	ZEC	DT+ RB	Survey	TE-VSC	GS Dept
CP. 0	TOTEM	CMX	CSC RE	TK PIX	HCAL	EN Dept	RP

PX56 Plug
CLOSED

2020

TX54 Plug
CLOSED

January – Week 4

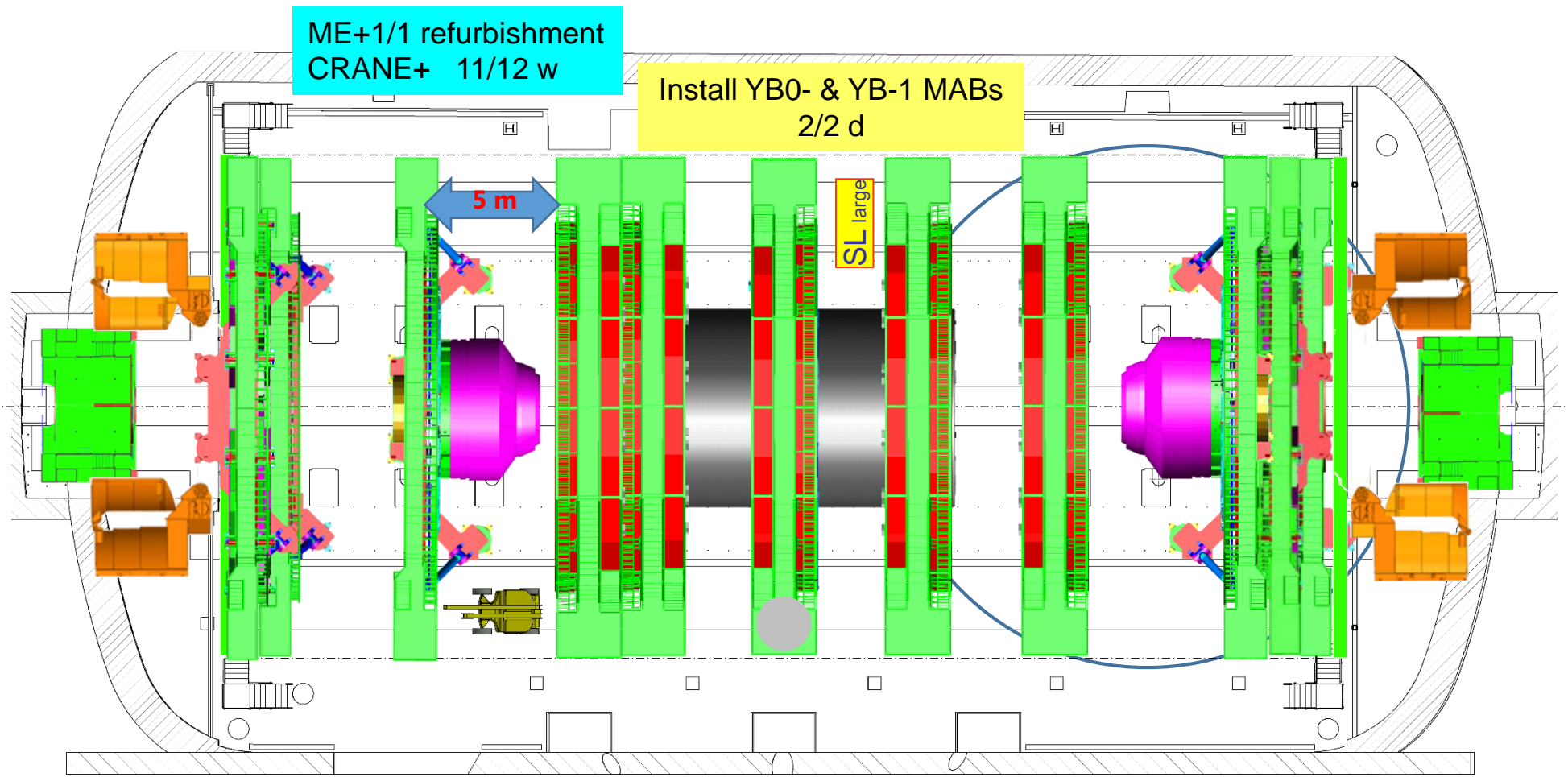
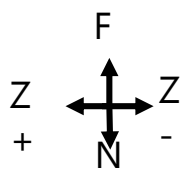



Crane

Cryo.	█	EL power	█	Water cool.	█	Database	█
IT	█	Magnet	█	C6F14	█	Gas	█
SL. 0	GEM	ECAL	ZEC	DT+ RB	Survey	TE-VSC	GS Dept
CP. 0	TOTEM	CMX	CSC RE	TK PIX	HCAL	EN Dept	RP

PX56 Plug
CLOSED

2020

TX54 Plug
CLOSED

January – Week 5

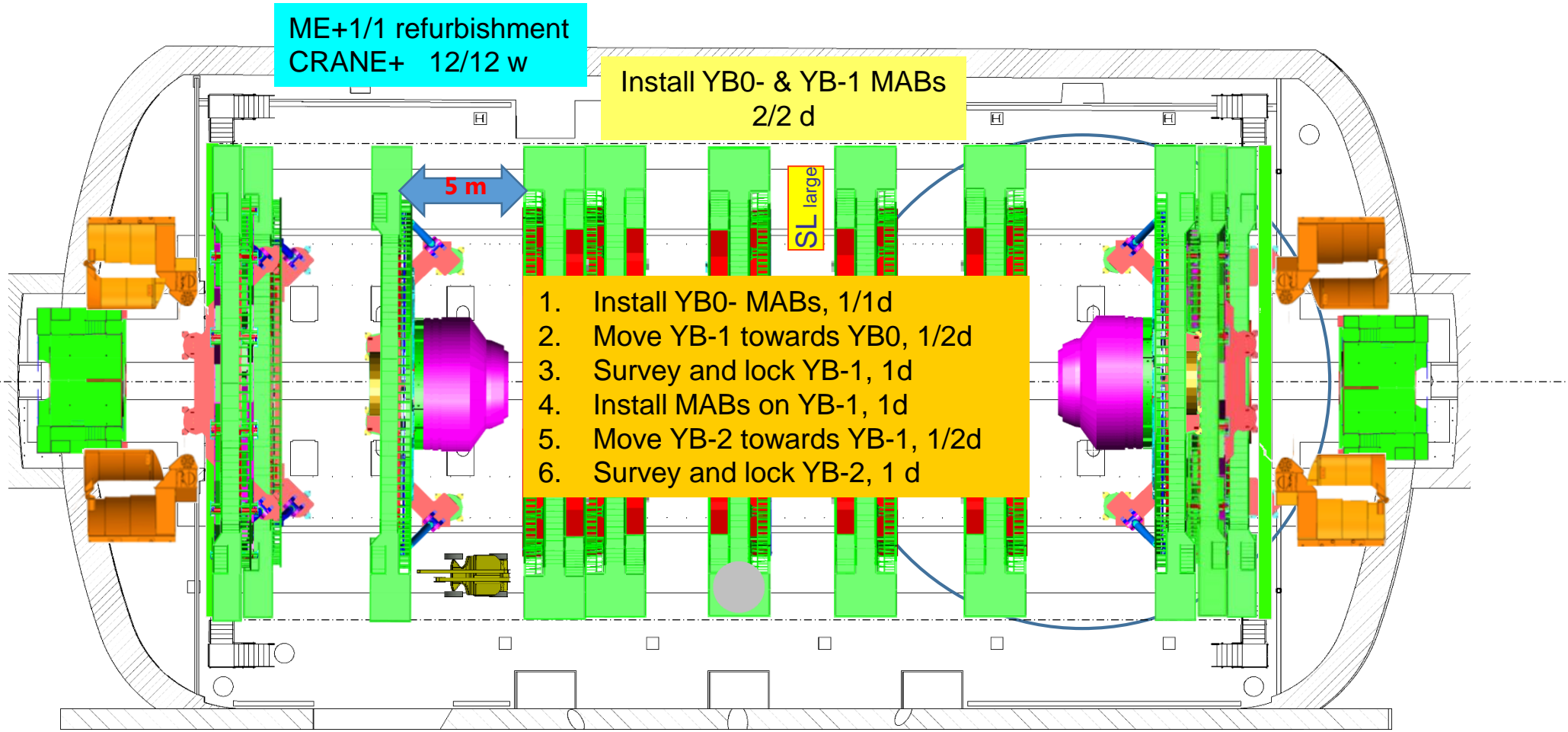
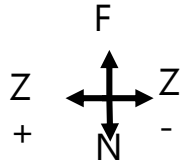

5m



Crane

Cryo.	█	EL power	█	Water cool.	█	Database	█								
IT	█	Magnet	█	C6F14	█	Gas	█								
SL.	0	GEM	█	ECAL	█	ZEC	█	DT+ RB	█	Survey	█	TE-VSC	█	GS Dept	█
CP.	0	TOTEM	█	CMX	█	CSC RE	█	TK PIX	█	HCAL	█	EN Dept	█	RP	█

PX56 Plug CLOSED
TX54 Plug CLOSED

2020
January – Week 6

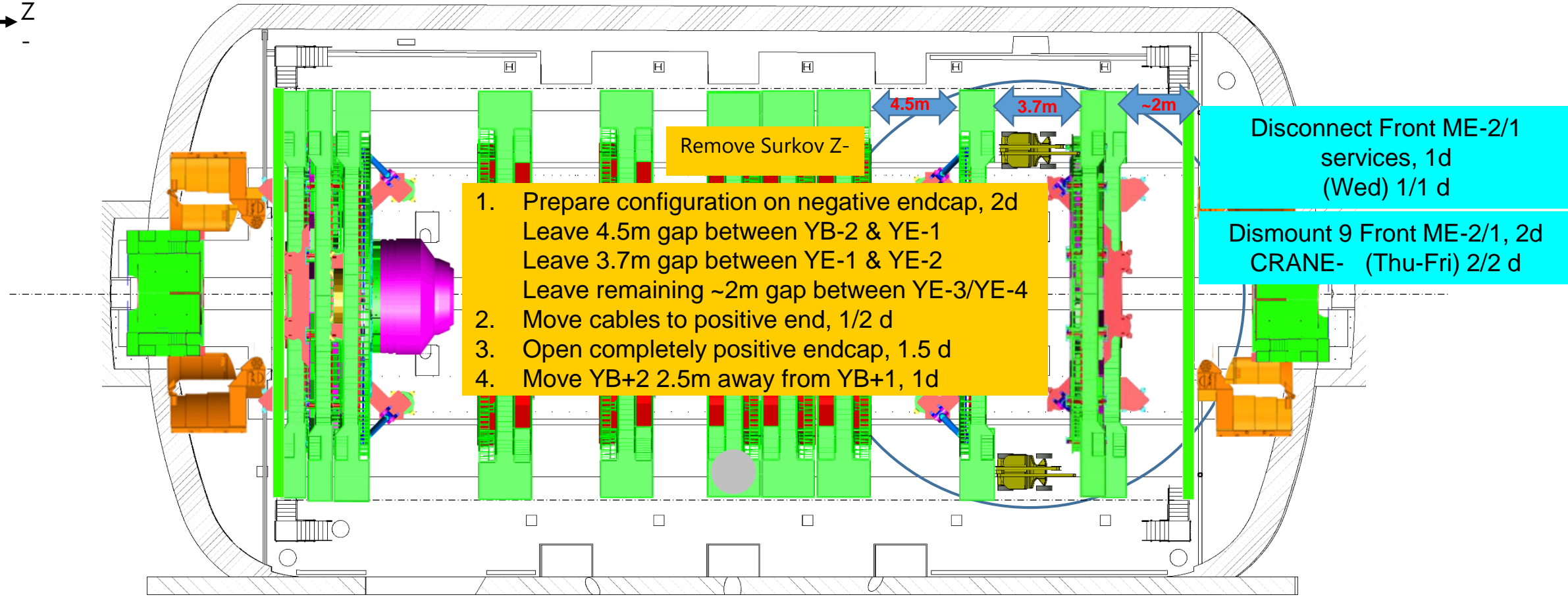
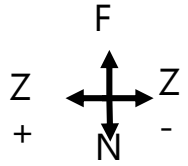

5m



Crane

Cryo.	<input type="checkbox"/>	EL power	<input type="checkbox"/>	Water cool.	<input type="checkbox"/>	Database	<input type="checkbox"/>	
IT	<input type="checkbox"/>	Magnet	<input type="checkbox"/>	C6F14	<input type="checkbox"/>	Gas	<input type="checkbox"/>	
SL.	0	GEM	ECAL	ZEC	DT+ RB	Survey	TE-VSC	GS Dept
CP.	0	TOTEM	CMX	CSC RE	TK PIX	HCAL	EN Dept	RP

PX56 Plug
CLOSED

TX54 Plug
CLOSED

2020

February – Week 7

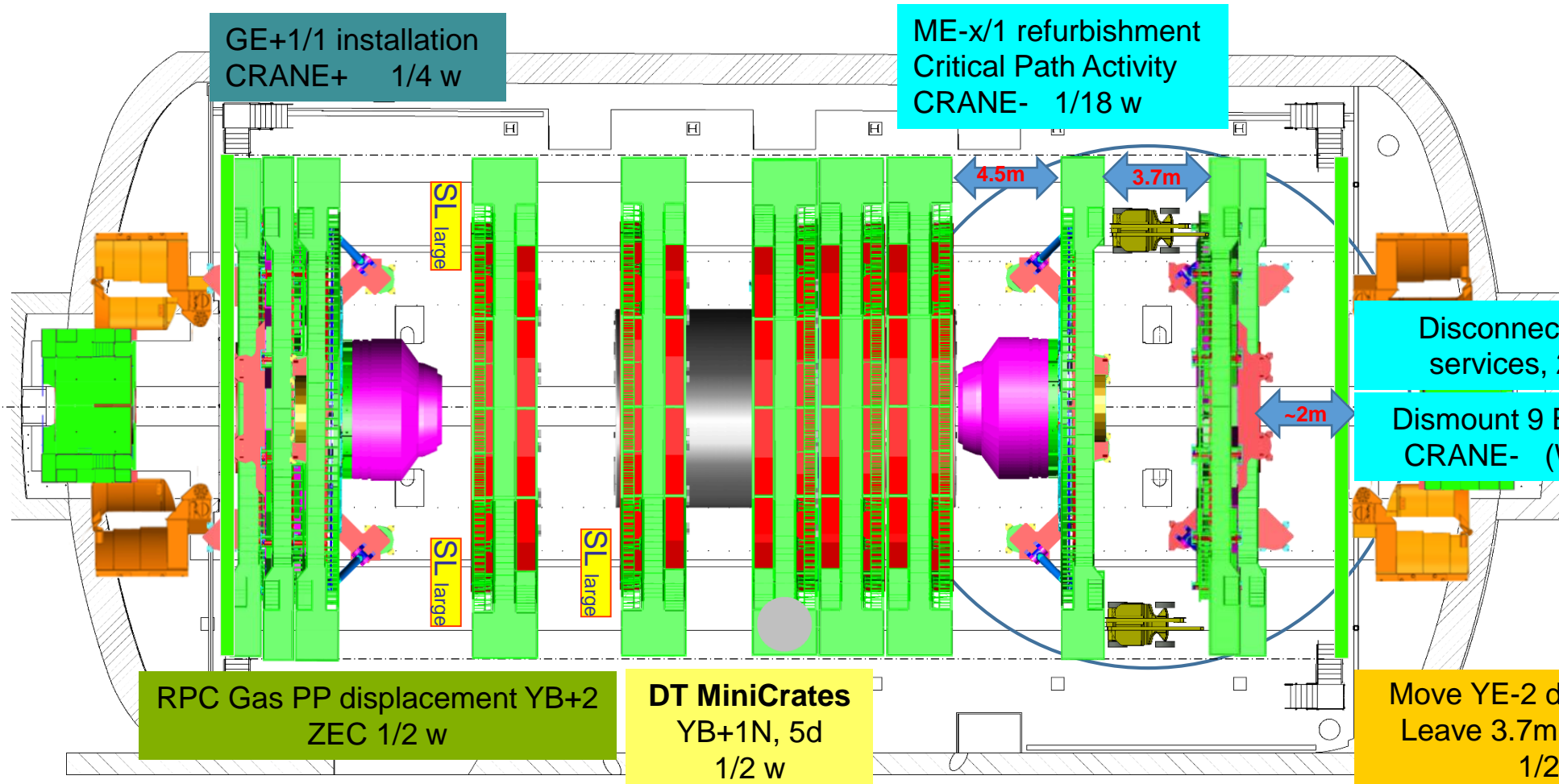
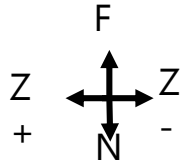



Crane

Cryo.	█	EL power	█	Water cool.	█	Database	█
IT	█	Magnet	█	C6F14	█	Gas	█
SL. 0	GEM	ECAL	ZEC	DT+ RB	Survey	TE-VSC	GS Dept
CP. 0	TOTEM	CMX	CSC RE	TK PIX	HCAL	EN Dept	RP

PX56 Plug CLOSED	2020
TX54 Plug CLOSED	February – Week 8

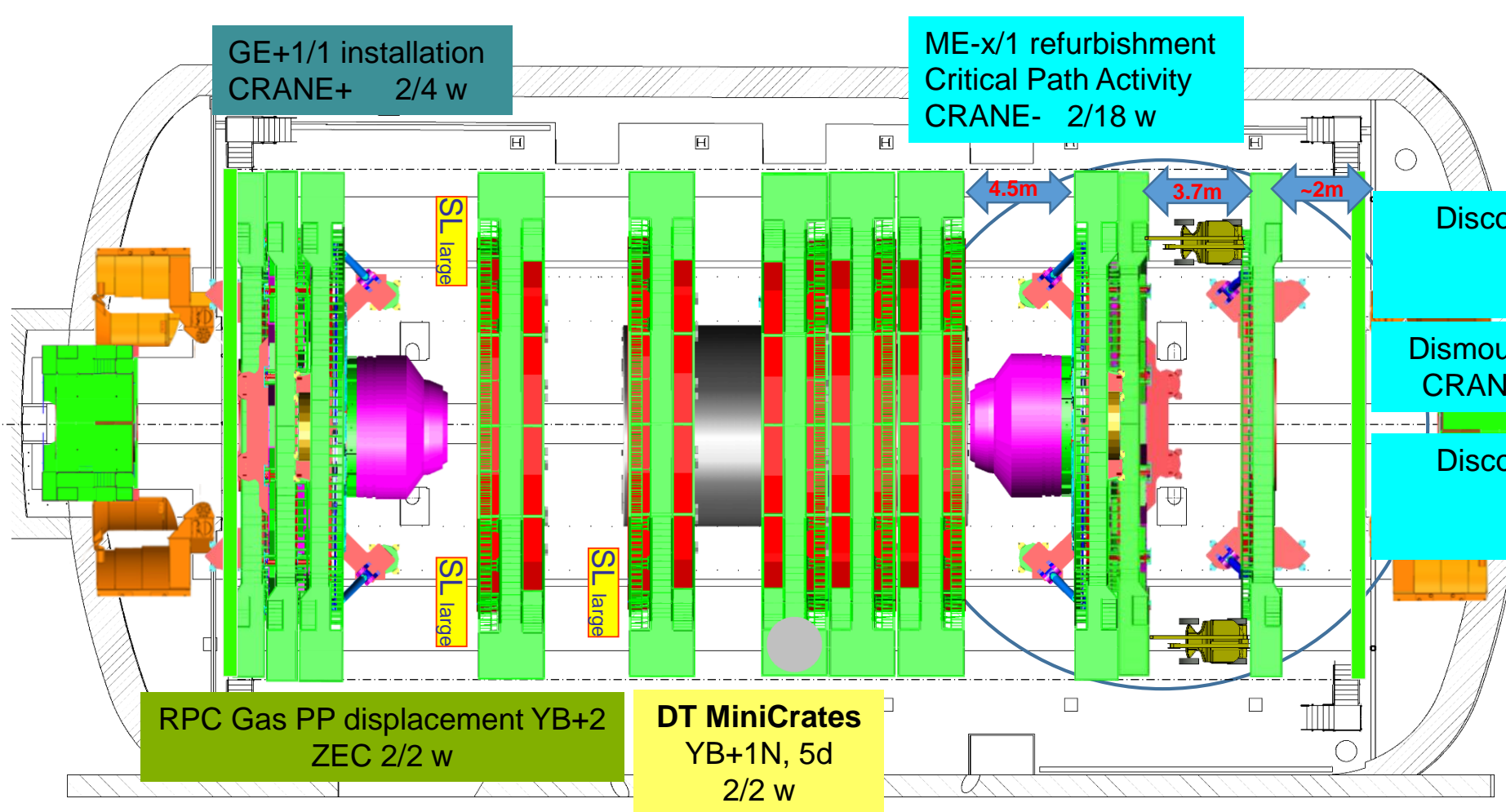
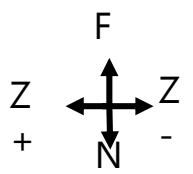



Crane

Cryo.	█	EL power	█	Water cool.	█	Database	█								
IT	█	Magnet	█	C6F14	█	Gas	█								
SL.	0	GEM	█	ECAL	█	ZEC	█	DT+ RB	█	Survey	█	TE-VSC	█	GS Dept	█
CP.	0	TOTEM	█	CMX	█	CSC RE	█	TK PIX	█	HCAL	█	EN Dept	█	RP	█

PX56 Plug
CLOSED

TX54 Plug
CLOSED

2020

February – Week 9

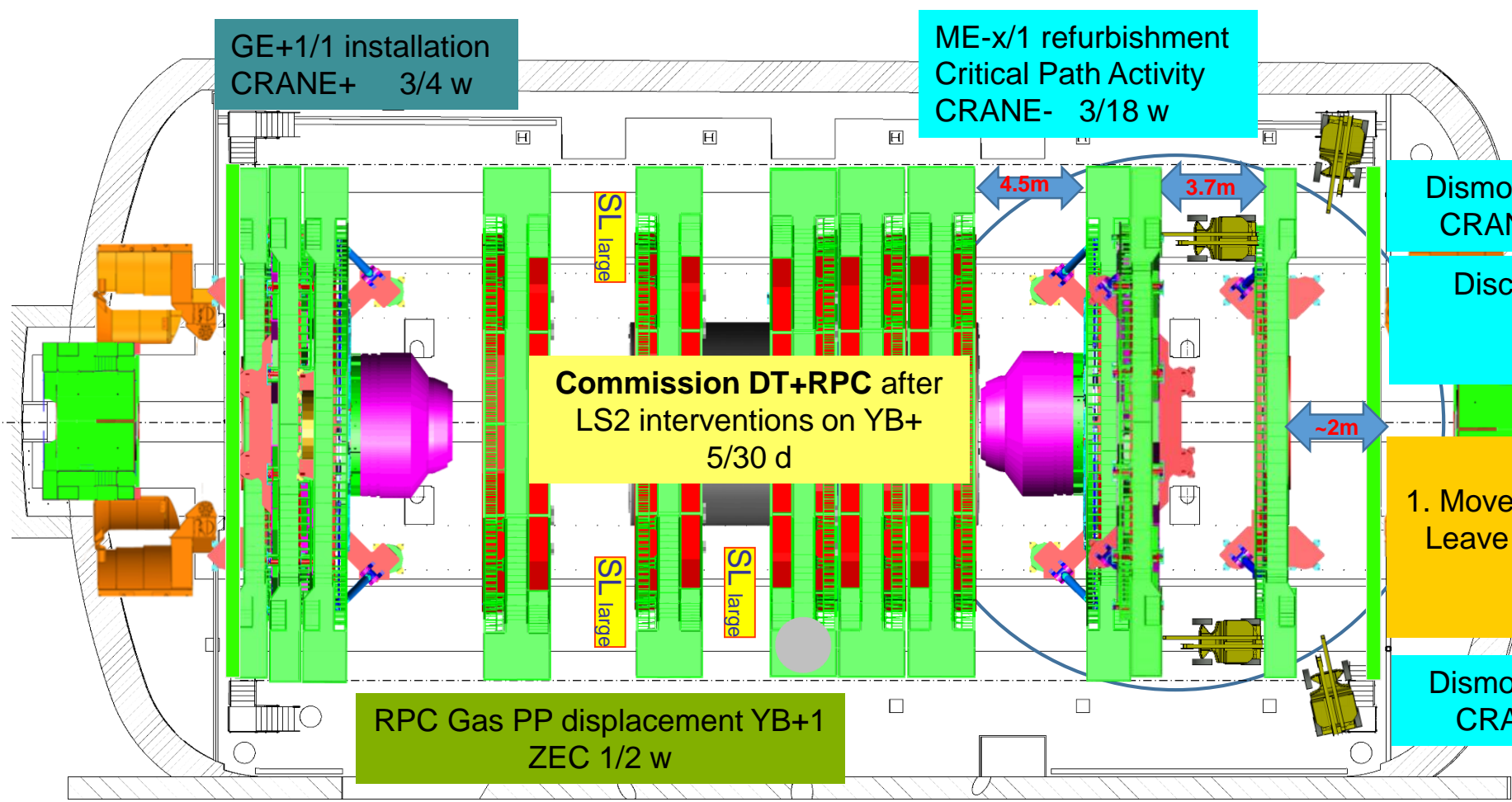
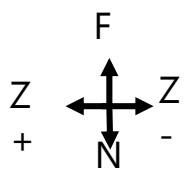

Dismount 9 Back ME-3/1, 2d
CRANE- (Mon-Tue) 2/2 d

Disconnect Front ME-4/1
services, 1d
(Tue) 1/1 d

1. Move YE-3 disk towards YE2
Leave ~5.5m gap YE-3/YE-4
(Wed) 1 d

Dismount 9 Front ME-4/1, 2d
CRANE- (Thu-Fri) 2/2 d

5m



Cryo.	█	EL power	█	Water cool.	█	Database	█
IT	█	Magnet	█	C6F14	█	Gas	█
SL. 0	GEM	ECAL	ZEC	DT+ RB	Survey	TE-VSC	GS Dept
CP. 0	TOTEM	CMX	CSC RE	TK PIX	HCAL	EN Dept	RP

PX56 Plug CLOSED	2020
TX54 Plug CLOSED	March – Week 10

Crane

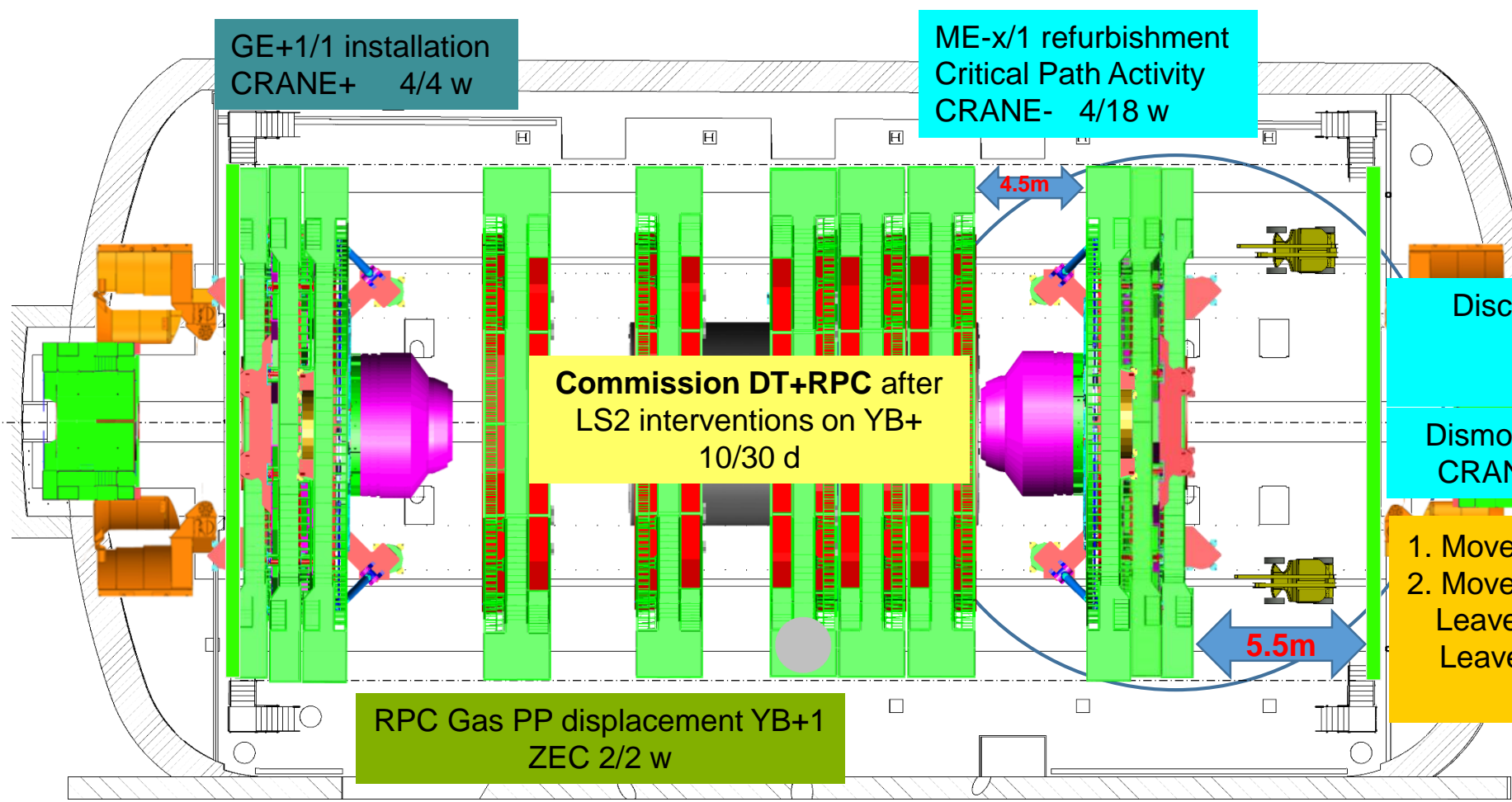
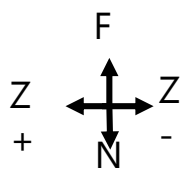

**Disconnect Back ME-4/1
services, 2d
(Mon-Tue) 2/2 d**

**Dismount 9 Back ME-4/1, 2d
CRANE- (Wed-Thu) 2/2 d**

1. Move YE-3 disk towards YE4
 2. Move YE-2 disk towards YE3
- Leave 3.7m gap YE-1/YE-2
Leave ~2m gap YE-3/YE-4
(Fri) 1 d

5m



Crane

Cryo.	<input type="checkbox"/>	EL power	<input type="checkbox"/>	Water cool.	<input type="checkbox"/>	Database	<input type="checkbox"/>	
IT	<input type="checkbox"/>	Magnet	<input type="checkbox"/>	C6F14	<input type="checkbox"/>	Gas	<input type="checkbox"/>	
SL.	0	GEM	ECAL	ZEC	DT+ RB	Survey	TE-VSC	GS Dept
CP.	0	TOTEM	CMX	CSC RE	TK PIX	HCAL	EN Dept	RP

PX56 Plug CLOSED
TX54 Plug CLOSED

2020
March – Week 11

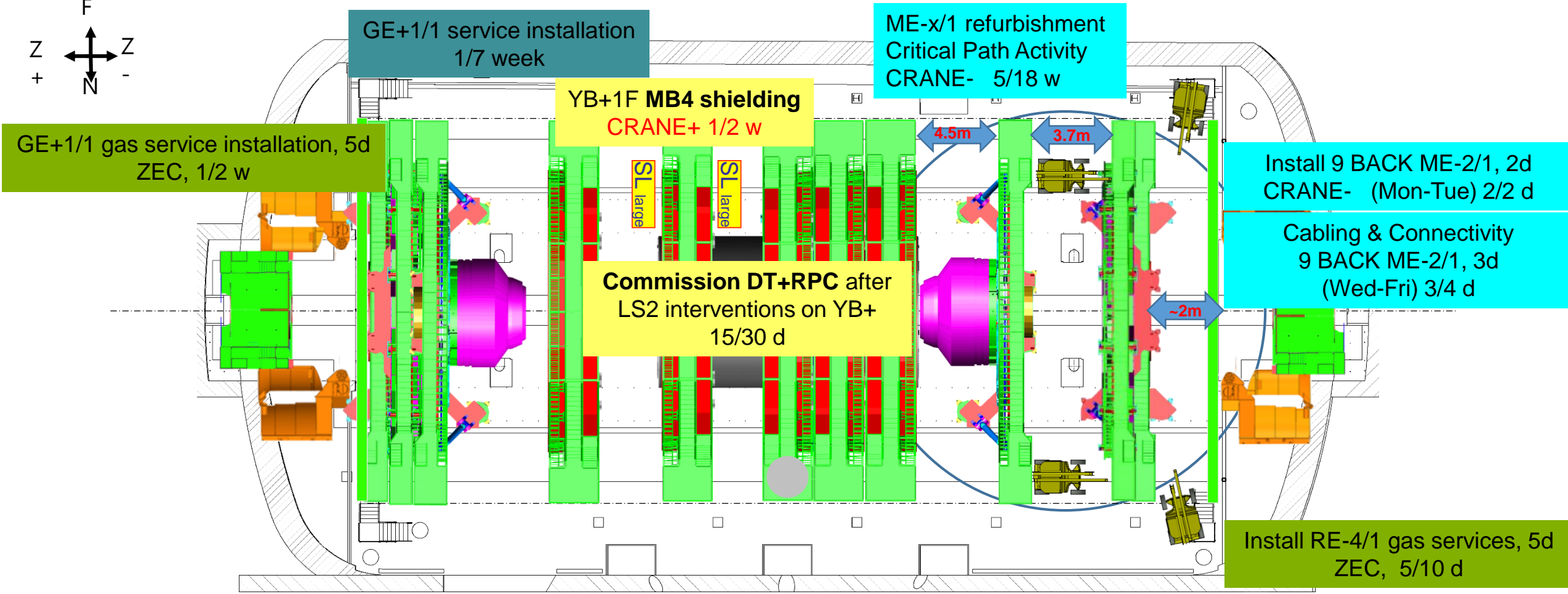
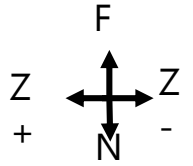

5m



Cryo.	█	EL power	█	Water cool.	█	Database	█
IT	█	Magnet	█	C6F14	█	Gas	█
SL. 0	GEM	ECAL	ZEC	DT+ RB	Survey	TE-VSC	GS Dept
CP. 0	TOTEM	CMX	CSC RE	TK PIX	HCAL	EN Dept	RP

PX56 Plug CLOSED	2020
TX54 Plug CLOSED	March – Week 12

Crane

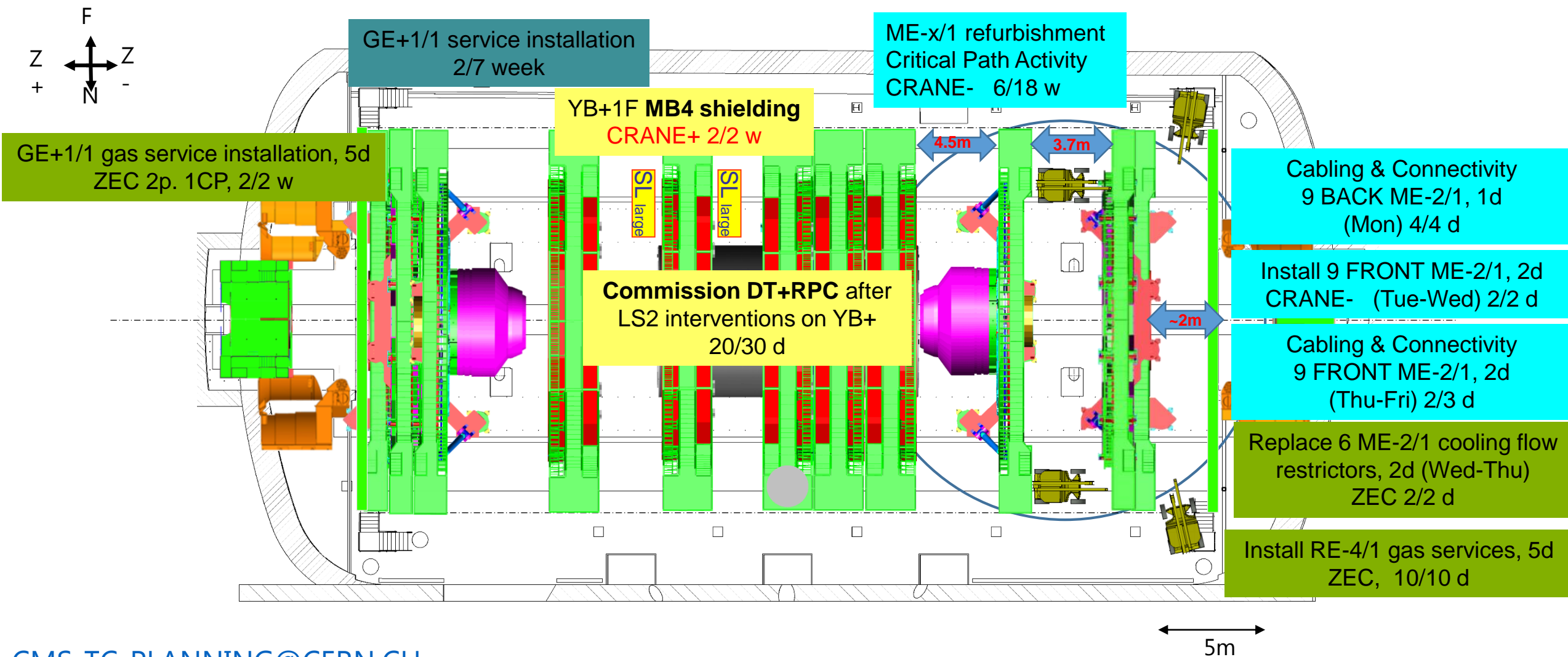
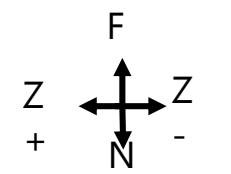



Cryo.	■	EL power	■	Water cool.	■	Database	■
IT	■	Magnet	■	C6F14	■	Gas	■
SL. 0	GEM	ECAL	ZEC	DT+ RB	Survey	TE-VSC	GS Dept
CP. 0	TOTEM	CMX	CSC RE	TK PIX	HCAL	EN Dept	RP

PX56 Plug CLOSED	2020
TX54 Plug CLOSED	March – Week 13

Crane

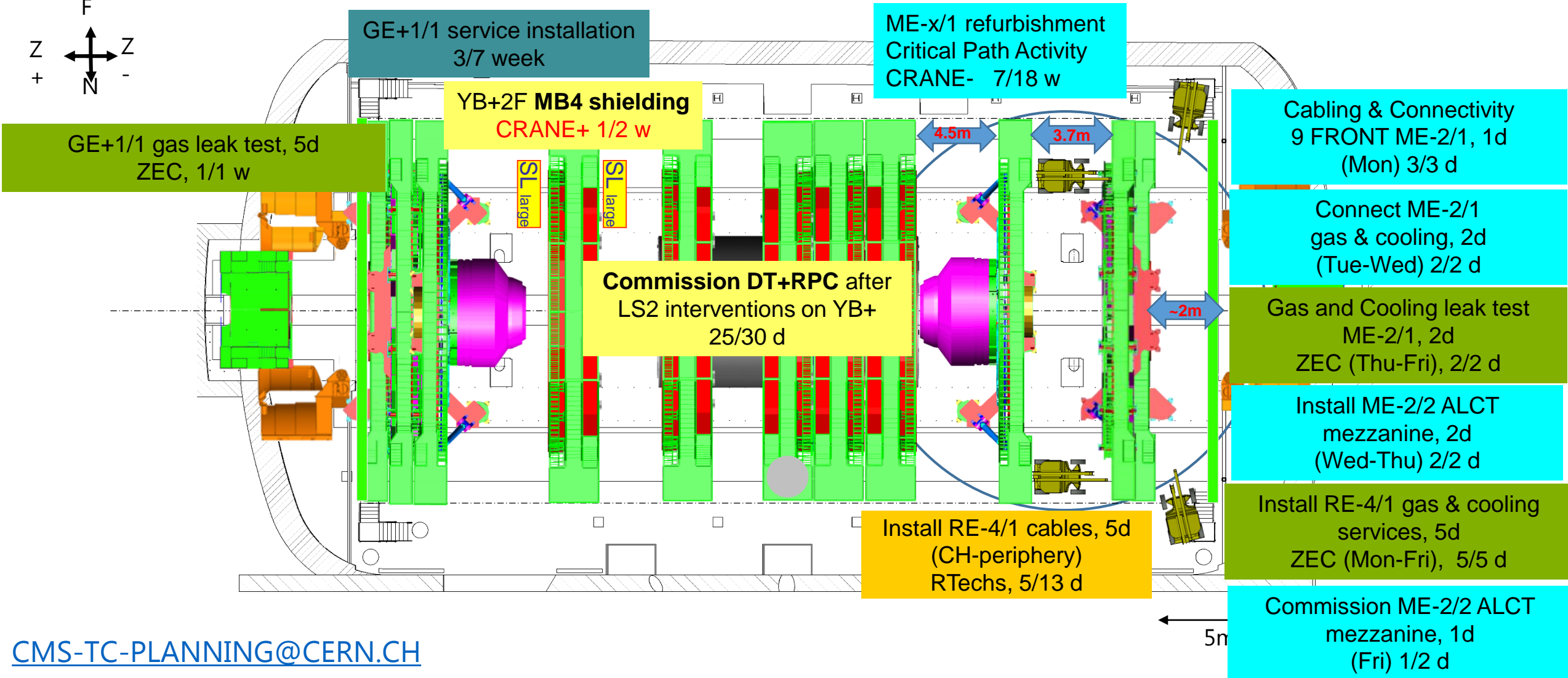
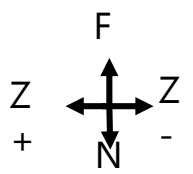

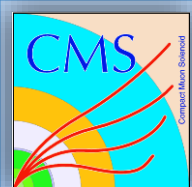

Crane

Cryo.		EL power		Water cool.		Database	
IT		Magnet		C6F14		Gas	
SL. 0	GEM	ECAL	ZEC	DT+ RB	Survey	TE-VSC	GS Dept
CP. 0	TOTEM	CMX	CSC RE	TK PIX	HCAL	EN Dept	RP

PX56 Plug CLOSED

2020

TX54 Plug CLOSED

March – Week 14

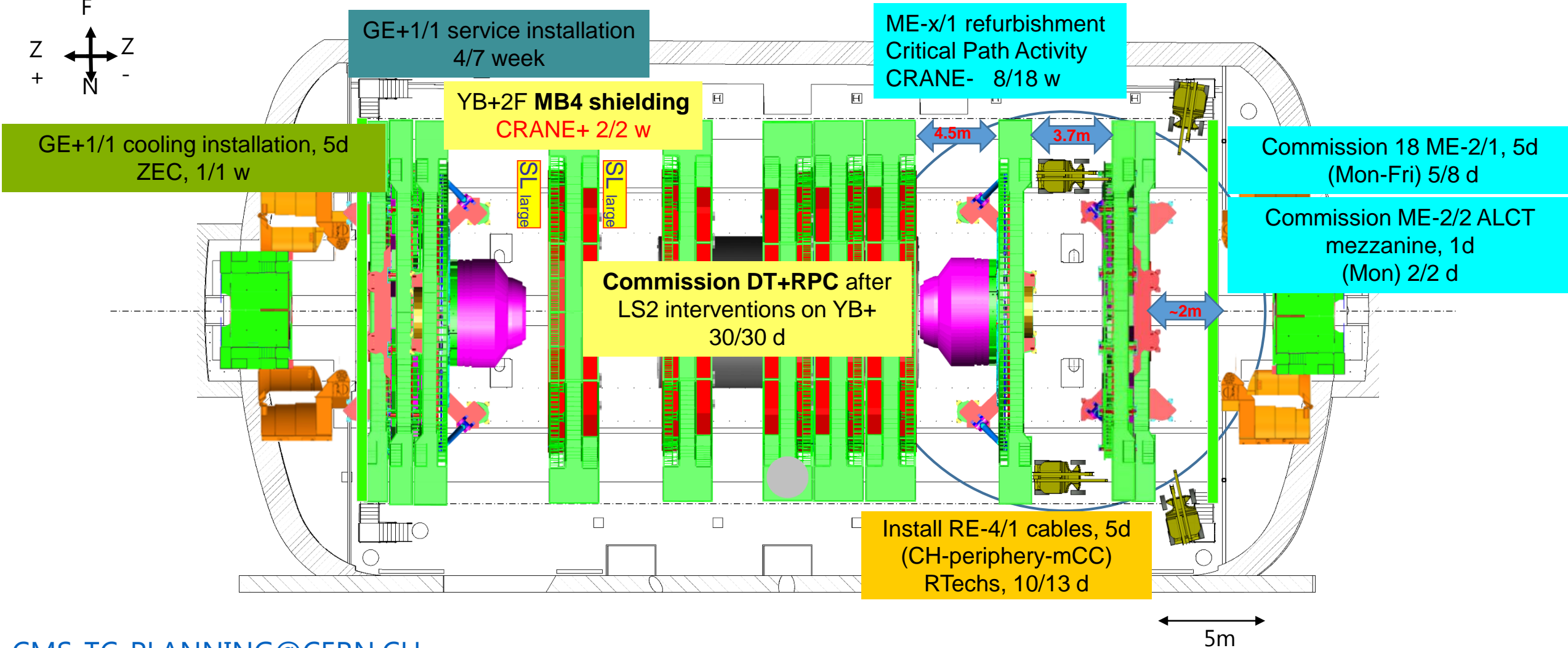
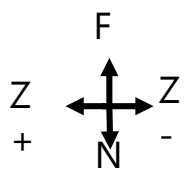



Cryo.	■	EL power	■	Water cool.	■	Database	■
IT	■	Magnet	■	C6F14	■	Gas	■
SL. 0	GEM	ECAL	ZEC	DT+ RB	Survey	TE-VSC	GS Dept
CP. 0	TOTEM	CMX	CSC RE	TK PIX	HCAL	EN Dept	RP

PX56 Plug CLOSED	2020
TX54 Plug CLOSED	April – Week 15

Crane

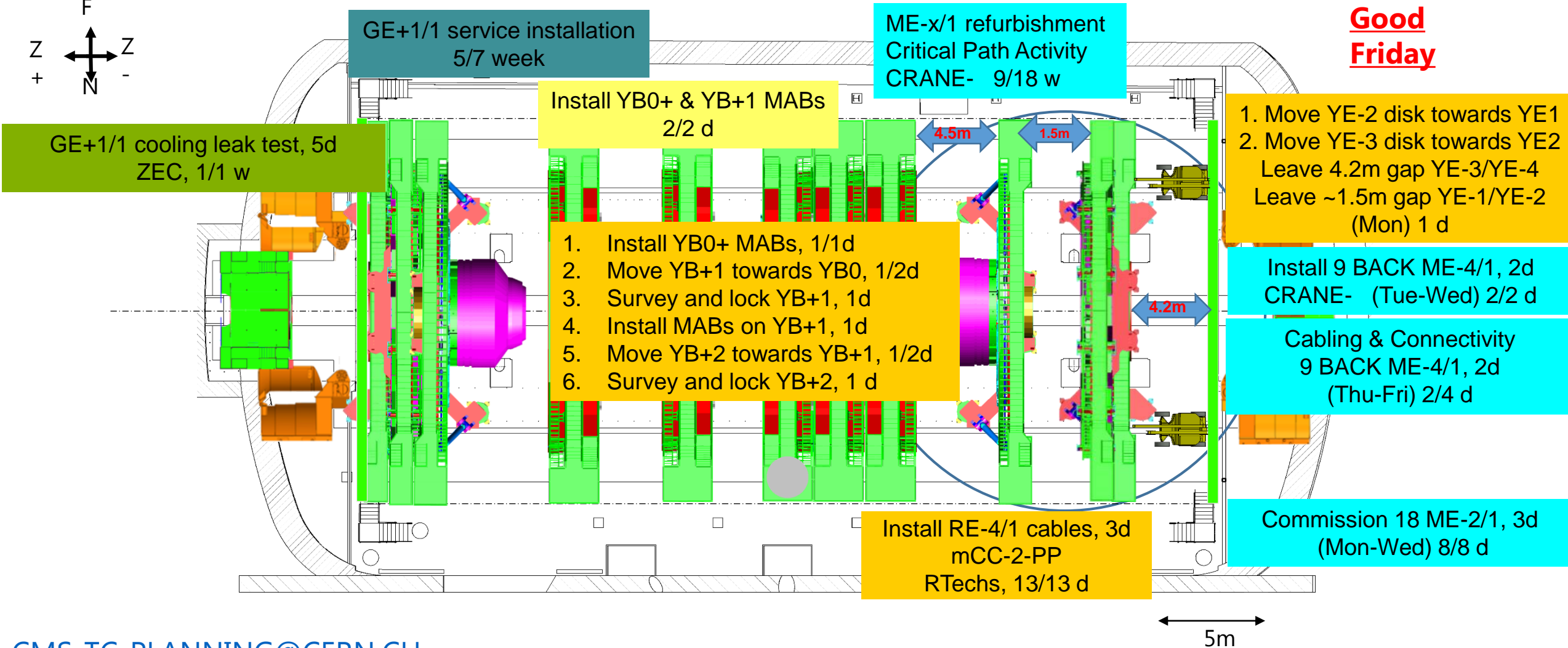
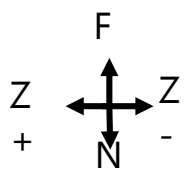

Good Friday

GE+1/1 cooling leak test, 5d
ZEC, 1/1 w

GE+1/1 service installation
5/7 week

ME-x/1 refurbishment
Critical Path Activity
CRANE- 9/18 w

Install YB0+ & YB+1 MABs
2/2 d

1. Install YB0+ MABs, 1/1d
2. Move YB+1 towards YB0, 1/2d
3. Survey and lock YB+1, 1d
4. Install MABs on YB+1, 1d
5. Move YB+2 towards YB+1, 1/2d
6. Survey and lock YB+2, 1 d

1. Move YE-2 disk towards YE1
 2. Move YE-3 disk towards YE2
- Leave 4.2m gap YE-3/YE-4
Leave ~1.5m gap YE-1/YE-2
(Mon) 1 d

Install 9 BACK ME-4/1, 2d
CRANE- (Tue-Wed) 2/2 d

Cabling & Connectivity
9 BACK ME-4/1, 2d
(Thu-Fri) 2/4 d

Install RE-4/1 cables, 3d
mCC-2-PP
RTechs, 13/13 d

Commission 18 ME-2/1, 3d
(Mon-Wed) 8/8 d

5m



Cryo.	█	EL power	█	Water cool.	█	Database	█								
IT	█	Magnet	█	C6F14	█	Gas	█								
SL.	0	GEM	█	ECAL	█	ZEC	█	DT+ RB	█	Survey	█	TE-VSC	█	GS Dept	█
CP.	0	TOTEM	█	CMX	█	CSC RE	█	TK PIX	█	HCAL	█	EN Dept	█	RP	█

PX56 Plug CLOSED

2020

TX54 Plug CLOSED

April – Week 16

Crane

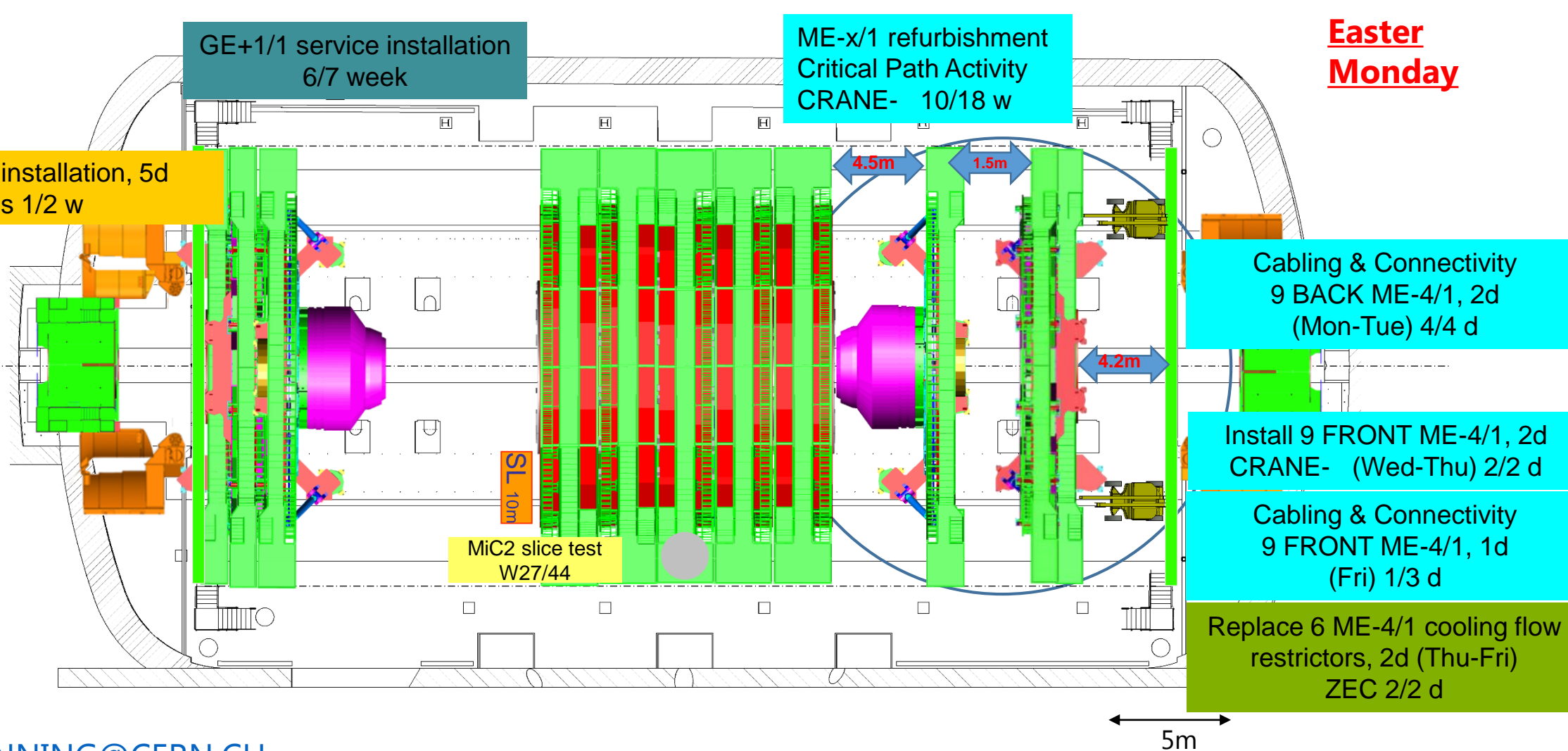
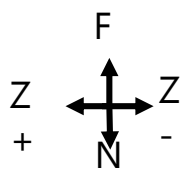

Easter Monday

GE+1/1 cable installation, 5d
RTechs 1/2 w

GE+1/1 service installation
6/7 week

ME-x/1 refurbishment
Critical Path Activity
CRANE- 10/18 w

Cabling & Connectivity
9 BACK ME-4/1, 2d
(Mon-Tue) 4/4 d

Install 9 FRONT ME-4/1, 2d
CRANE- (Wed-Thu) 2/2 d

Cabling & Connectivity
9 FRONT ME-4/1, 1d
(Fri) 1/3 d

Replace 6 ME-4/1 cooling flow
restrictors, 2d (Thu-Fri)
ZEC 2/2 d

SL 10m

MiC2 slice test
W27/44

5m



Crane

Cryo.		EL power		Water cool.		Database		
IT		Magnet		C6F14		Gas		
SL.	0	GEM	ECAL	ZEC	DT+ RB	Survey	TE-VSC	GS Dept
CP.	0	TOTEM	CMX	CSC RE	TK PIX	HCAL	EN Dept	RP

PX56 Plug
CLOSED

TX54 Plug
CLOSED

2020

April – Week 17

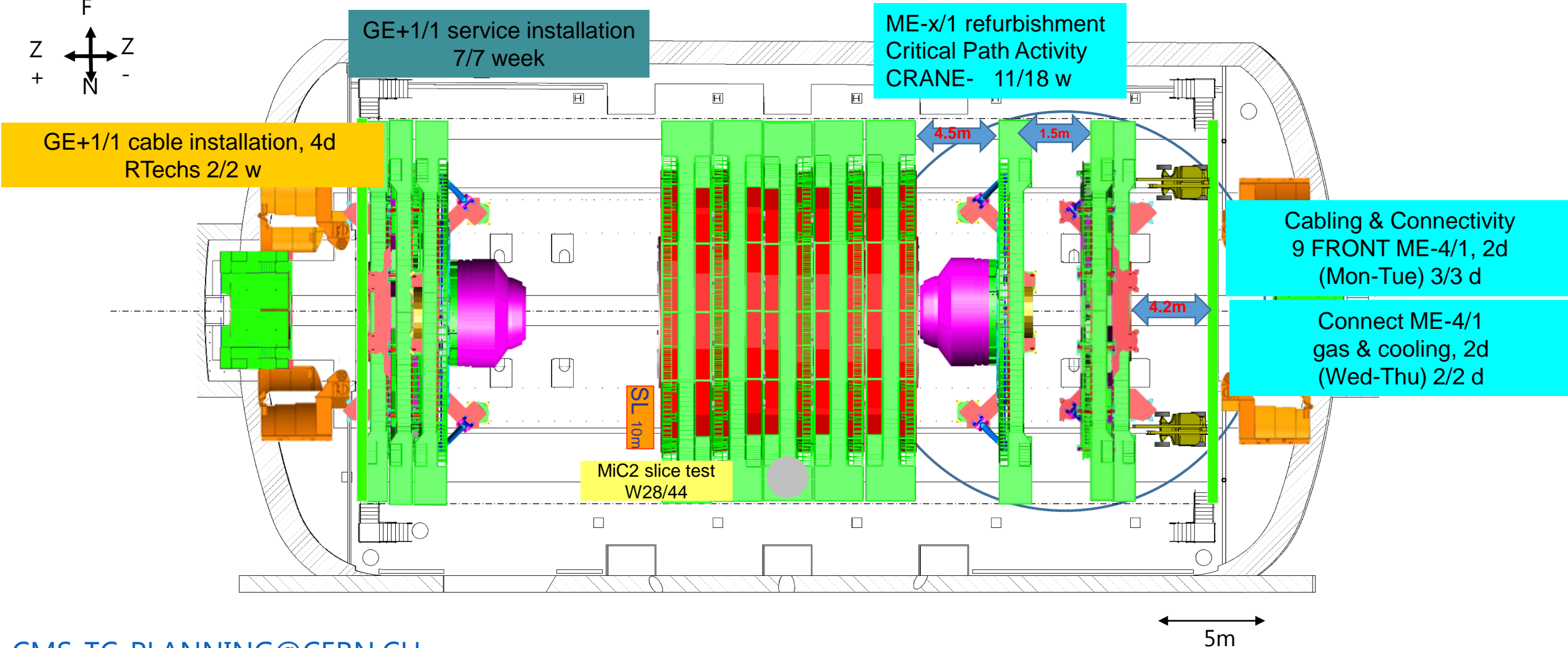
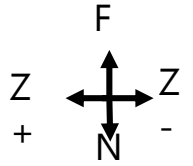



Cryo.	█	EL power	█	Water cool.	█	Database	█
IT	█	Magnet	█	C6F14	█	Gas	█
SL. 0	GEM	ECAL	ZEC	DT+ RB	Survey	TE-VSC	GS Dept
CP. 0	TOTEM	CMX	CSC RE	TK PIX	HCAL	EN Dept	RP

PX56 Plug CLOSED	2020
TX54 Plug CLOSED	April – Week 18

Crane

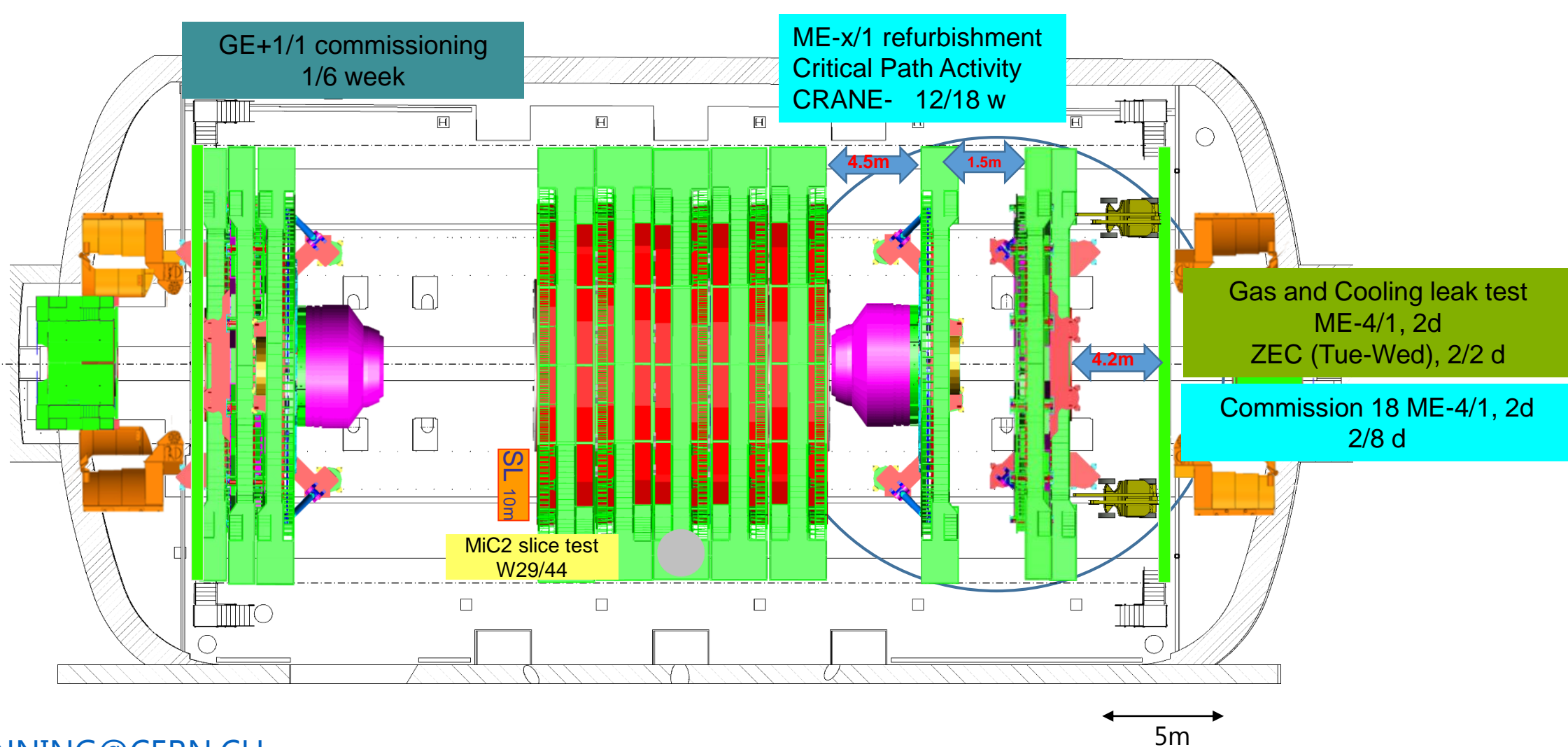
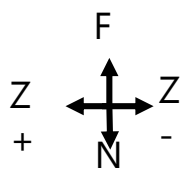



Crane

Cryo.	█	EL power	█	Water cool.	█	Database	█
IT	█	Magnet	█	C6F14	█	Gas	█
SL. 0	GEM	ECAL	ZEC	DT+ RB	Survey	TE-VSC	GS Dept
CP. 0	TOTEM	CMX	CSC RE	TK PIX	HCAL	EN Dept	RP

PX56 Plug CLOSED	2020
TX54 Plug CLOSED	May – Week 19

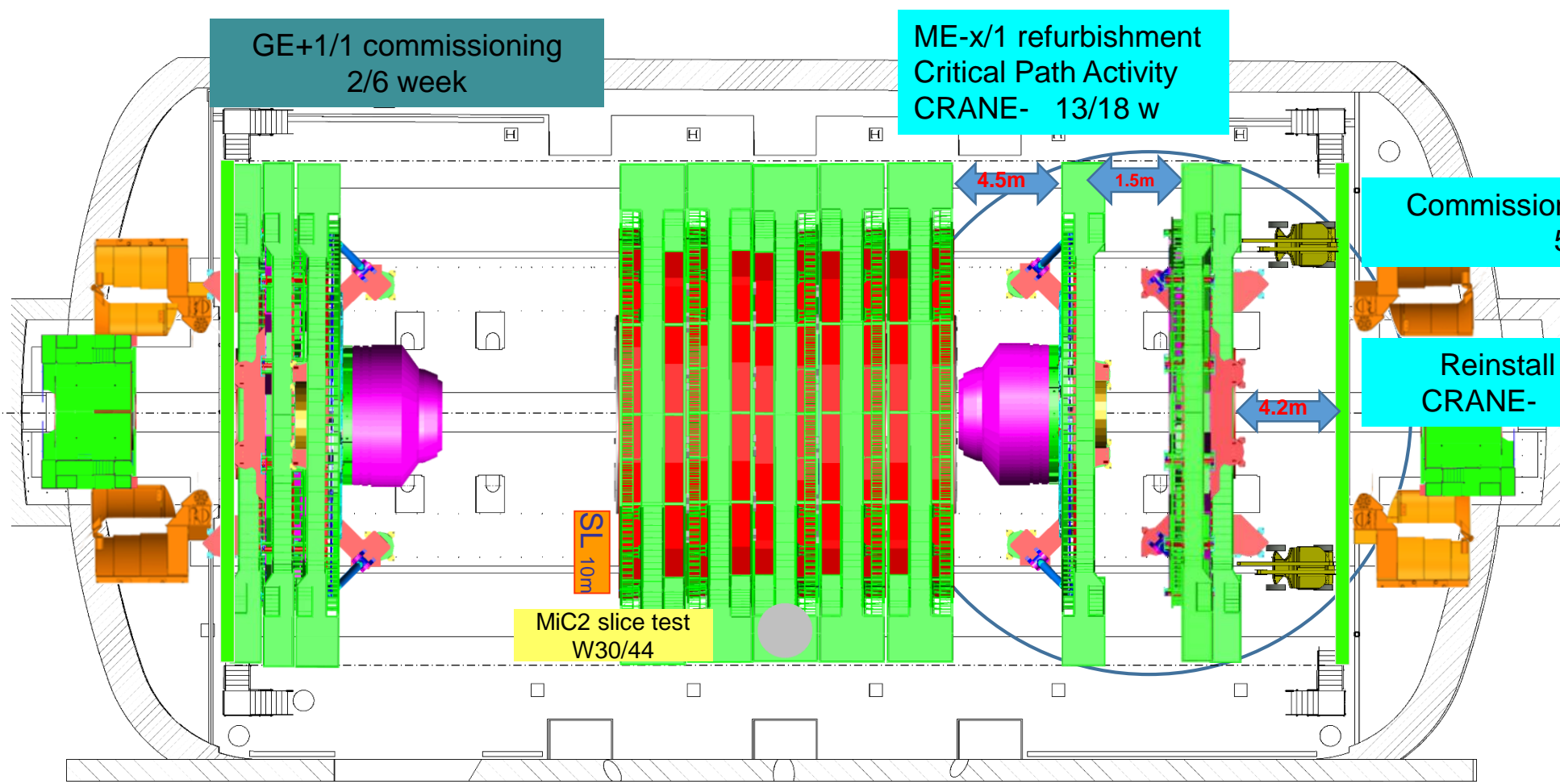
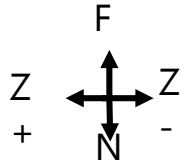

GE+1/1 commissioning
2/6 week

ME-x/1 refurbishment
Critical Path Activity
CRANE- 13/18 w

Commission 18 ME-4/1, 3d
5/8 d

Reinstall RE-4 SM, 2d
CRANE- (Thu-Fri) 2/6 d

SL 10m
MiC2 slice test
W30/44

5m



Crane

Cryo.	█	EL power	█	Water cool.	█	Database	█								
IT	█	Magnet	█	C6F14	█	Gas	█								
SL.	0	GEM	█	ECAL	█	ZEC	█	DT+ RB	█	Survey	█	TE-VSC	█	GS Dept	█
CP.	0	TOTEM	█	CMX	█	CSC RE	█	TK PIX	█	HCAL	█	EN Dept	█	RP	█

PX56 Plug CLOSED	2020
TX54 Plug CLOSED	May – Week 20

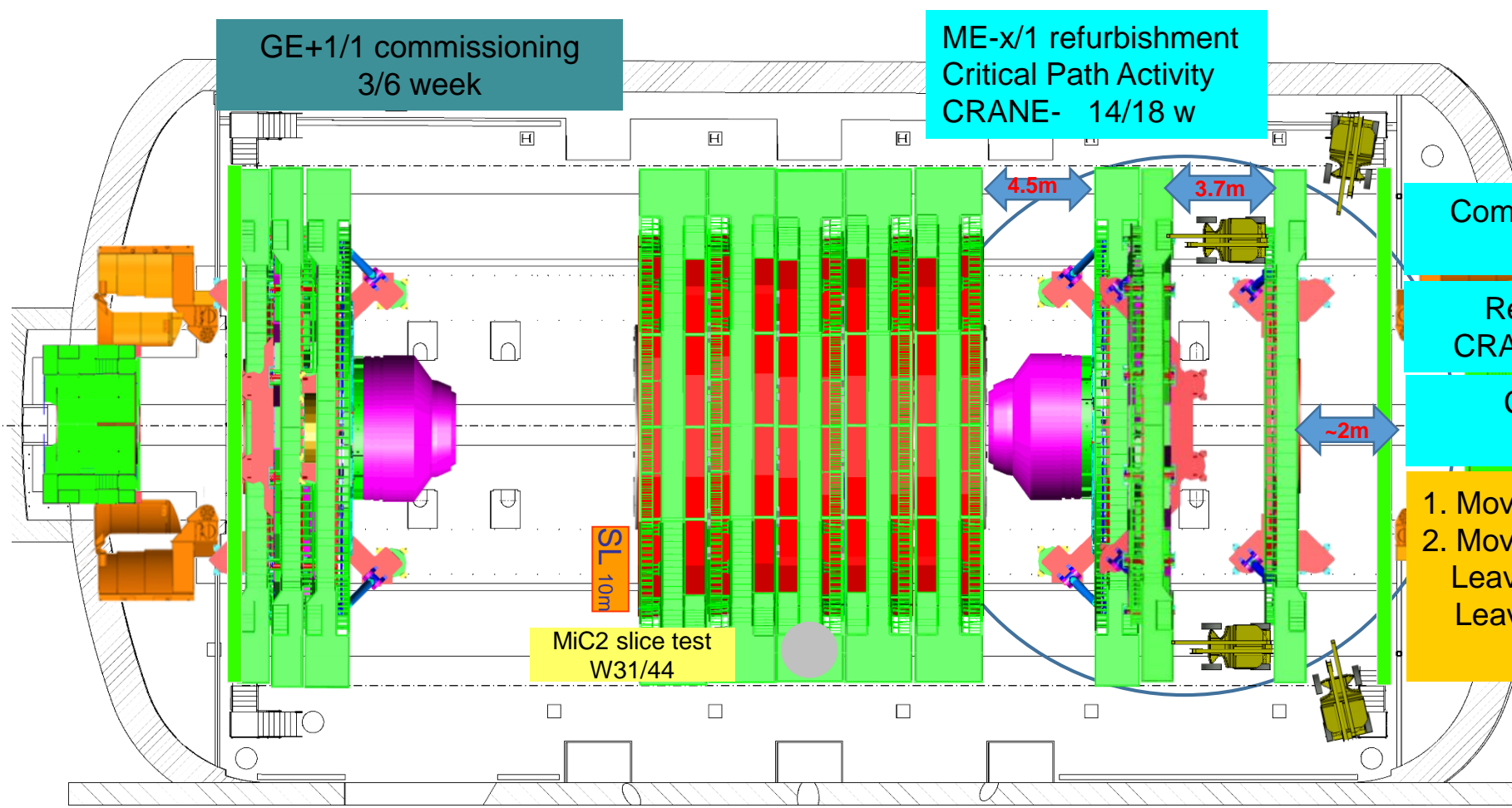
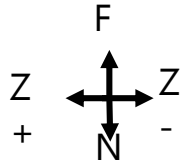

- Commission 18 ME-4/1, 3d
8/8 d
- Reinstall RE-4 SM, 4d
CRANE- (Mon-Thu) 6/6 d
- Cable RE-4 SM, 3d
(Tue-Thu) 3/6 d
- 1. Move YE-2 disk towards YE1
2. Move YE-3 disk towards YE4
Leave 3.7m gap YE-2/YE-3
Leave ~2m gap YE-3/YE-4
(Fri) 1 d

5m



Cryo.	█	EL power	█	Water cool.	█	Database	█
IT	█	Magnet	█	C6F14	█	Gas	█
SL. 0	GEM	ECAL	ZEC	DT+ RB	Survey	TE-VSC	GS Dept
CP. 0	TOTEM	CMX	CSC RE	TK PIX	HCAL	EN Dept	RP

PX56 Plug CLOSED	2020
TX54 Plug CLOSED	May – Week 21

Crane

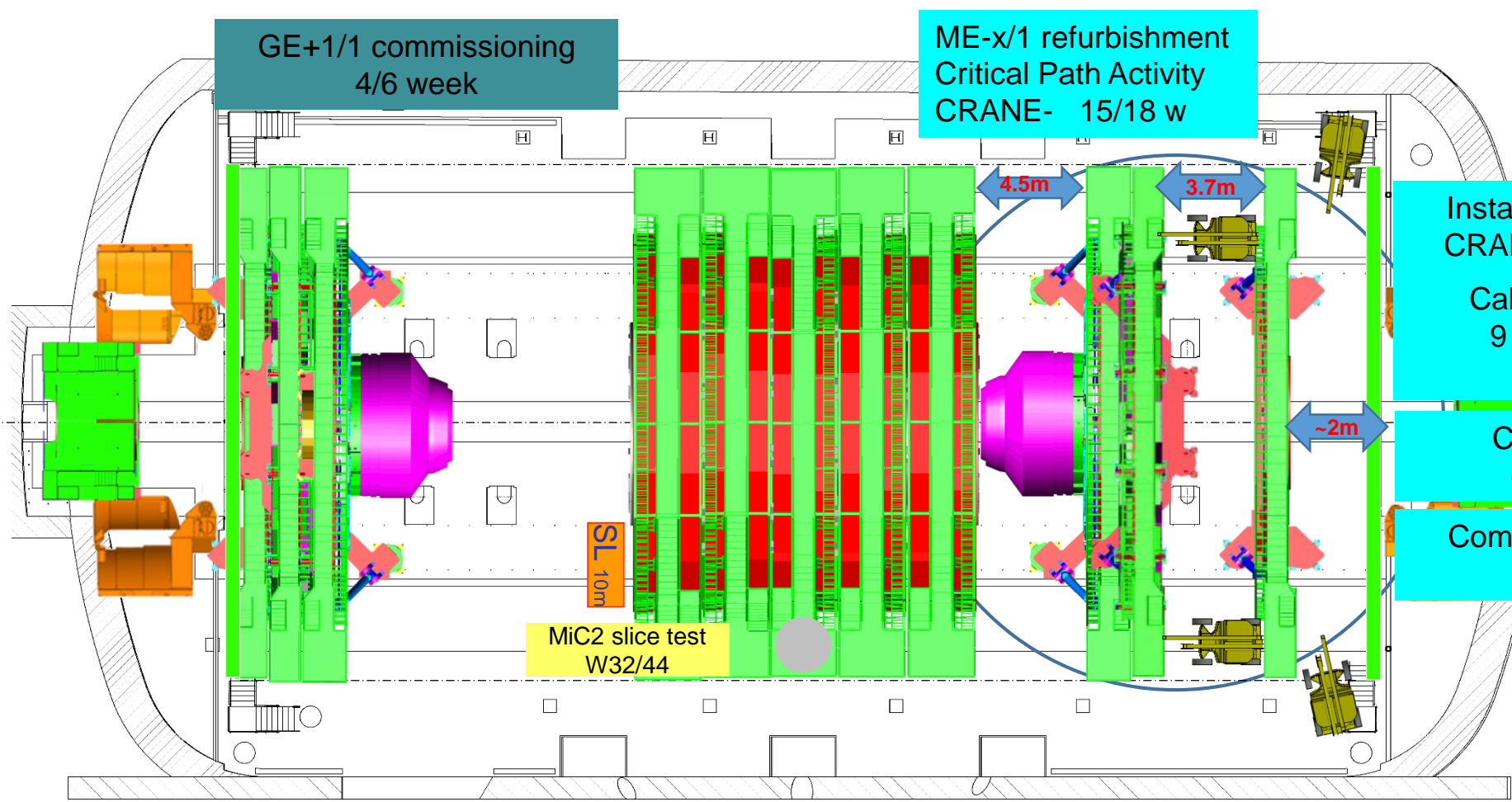
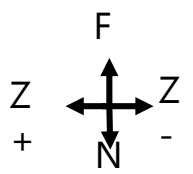

GE+1/1 commissioning
4/6 week

ME-x/1 refurbishment
Critical Path Activity
CRANE- 15/18 w

Install 9 BACK ME-3/1, 2d
CRANE- (Mon-Tue) 2/2 d

Cabling & Connectivity
9 BACK ME-3/1, 3d
(Wed-Fri) 3/4 d

Cable RE-4 SM, 3d
(Mon-Wed) 6/6 d

Commission RE-4 SM, 2d
2/8 d

5m

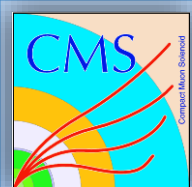

Cryo.	█	EL power	█	Water cool.	█	Database	█
IT	█	Magnet	█	C6F14	█	Gas	█
SL. 0	GEM	ECAL	ZEC	DT+ RB	Survey	TE-VSC	GS Dept
CP. 0	TOTEM	CMX	CSC RE	TK PIX	HCAL	EN Dept	RP

PX56 Plug CLOSED	2020
TX54 Plug CLOSED	May – Week 22

Crane

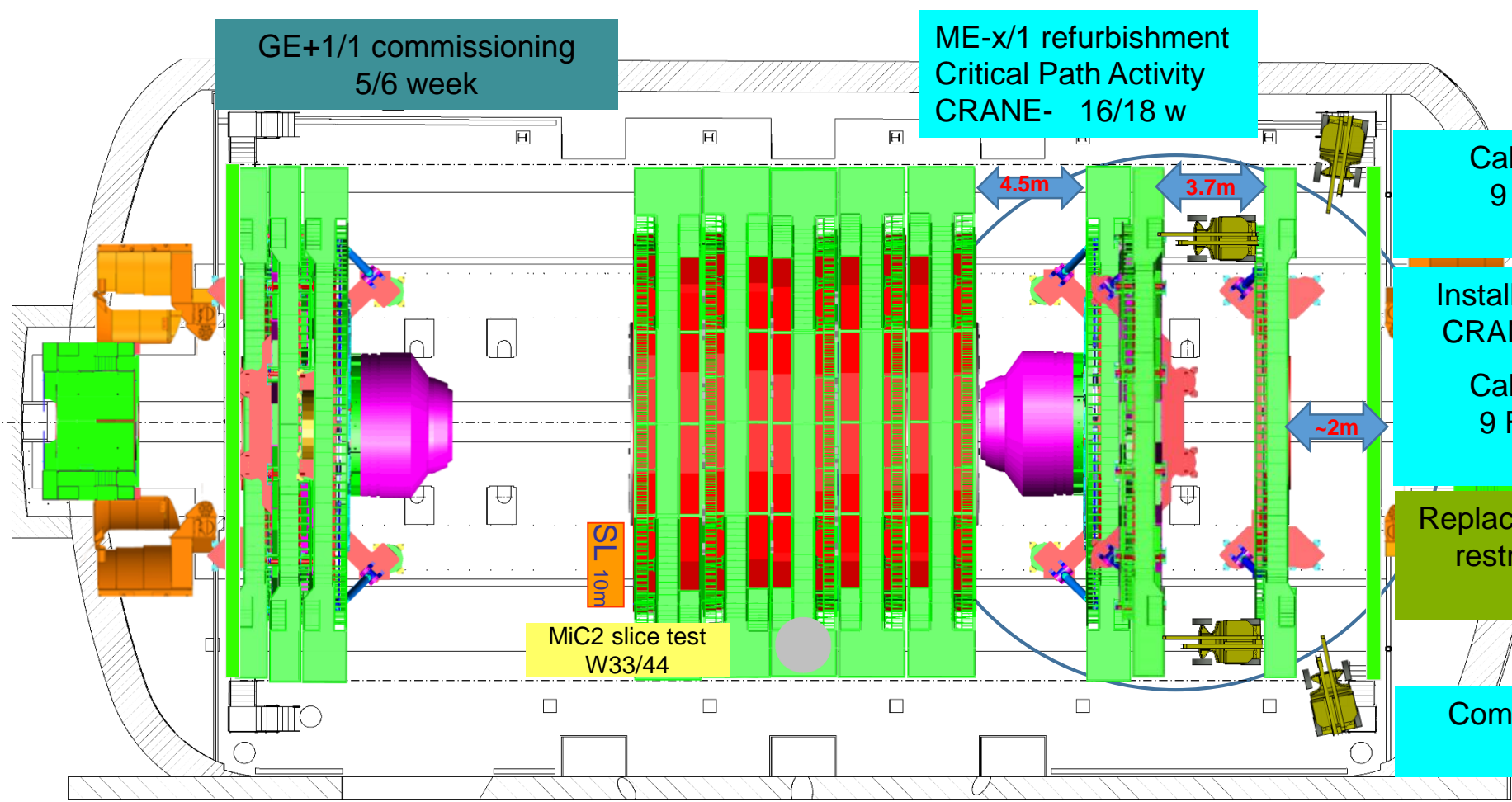
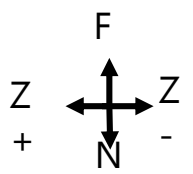

GE+1/1 commissioning
5/6 week

ME-x/1 refurbishment
Critical Path Activity
CRANE- 16/18 w

Cabling & Connectivity
9 BACK ME-3/1, 1d
(Mon) 4/4 d

Install 9 FRONT ME-3/1, 2d
CRANE- (Tue-Wed) 2/2 d

Cabling & Connectivity
9 FRONT ME-3/1, 2d
(Thu-Fri) 2/3 d

Replace 6 ME-3/1 cooling flow
restrictors, 2d (Wed-Thu)
ZEC 2/2 d

Commission RE-4 SM, 5d
7/8 d

MiC2 slice test
W33/44

SL
10m

4.5m

3.7m

~2m

5m



Cryo.	█	EL power	█	Water cool.	█	Database	█
IT	█	Magnet	█	C6F14	█	Gas	█
SL. 0	GEM	ECAL	ZEC	DT+ RB	Survey	TE-VSC	GS Dept
CP. 0	TOTEM	CMX	CSC RE	TK PIX	HCAL	EN Dept	RP

PX56 Plug
CLOSED

TX54 Plug
CLOSED

2020

June – Week 23

Crane

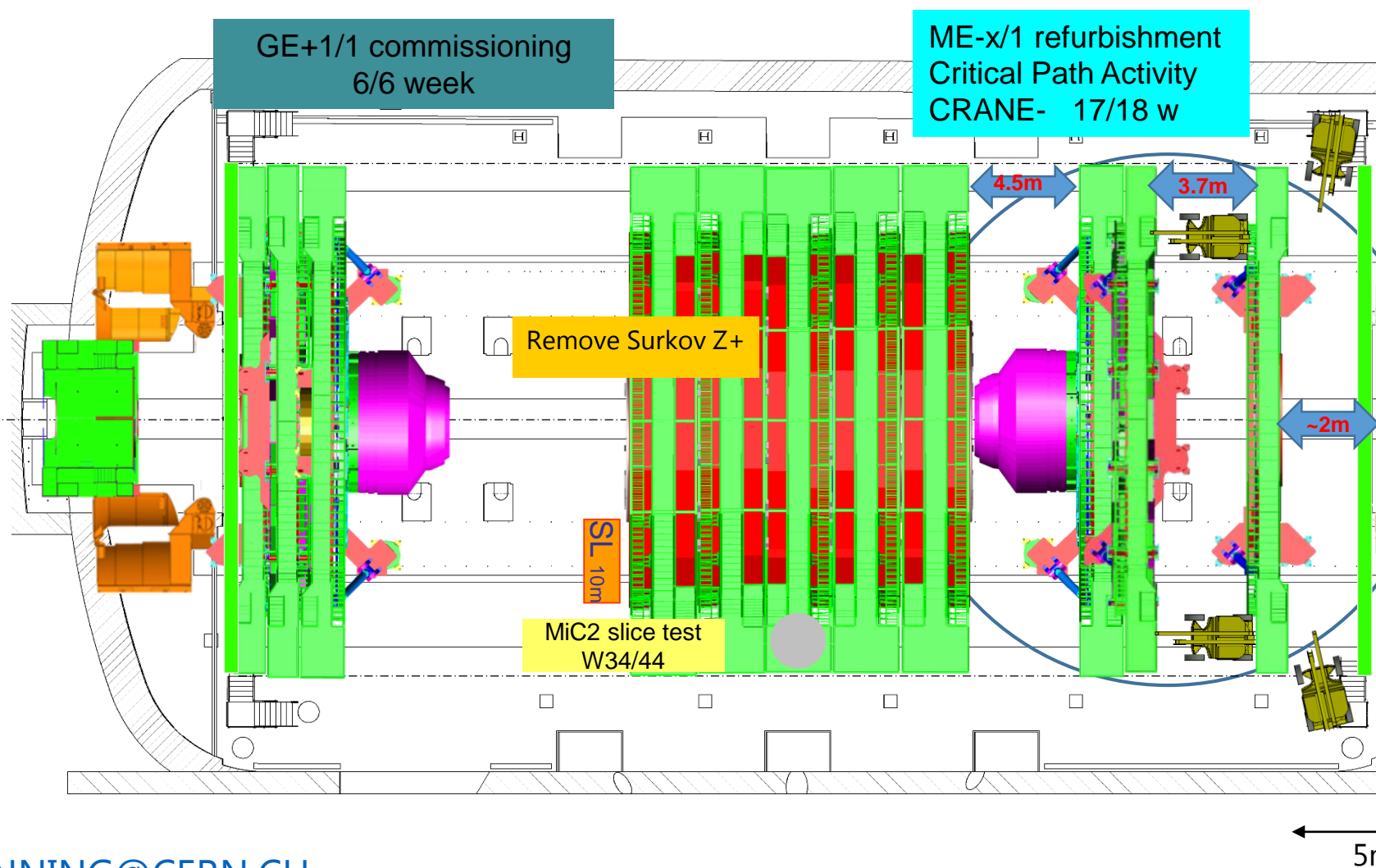
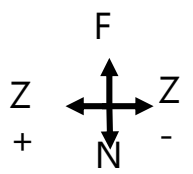

- Cabling & Connectivity
9 FRONT ME-3/1, 1d
(Mon) 3/3 d
- Connect ME-3/1
gas & cooling, 2d
(Tue-Wed) 2/2 d
- Gas and Cooling leak test
ME-3/1, 2d
ZEC (Thu-Fri), 2/2 d
- Commission RE-4 SM, 1d
8/8 d
- Install ME-3/2 ALCT
mezzanine, 2d
(Wed-Thu) 2/2 d
- Commission ME-3/2 ALCT
mezzanine, 1d
(Fri) 1/2 d



Cryo.	█	EL power	█	Water cool.	█	Database	█								
IT	█	Magnet	█	C6F14	█	Gas	█								
SL.	0	GEM	█	ECAL	█	ZEC	█	DT+ RB	█	Survey	█	TE-VSC	█	GS Dept	█
CP.	0	TOTEM	█	CMX	█	CSC RE	█	TK PIX	█	HCAL	█	EN Dept	█	RP	█

PX56 Plug
CLOSED

2020

TX54 Plug
CLOSED

June – Week 24

Crane

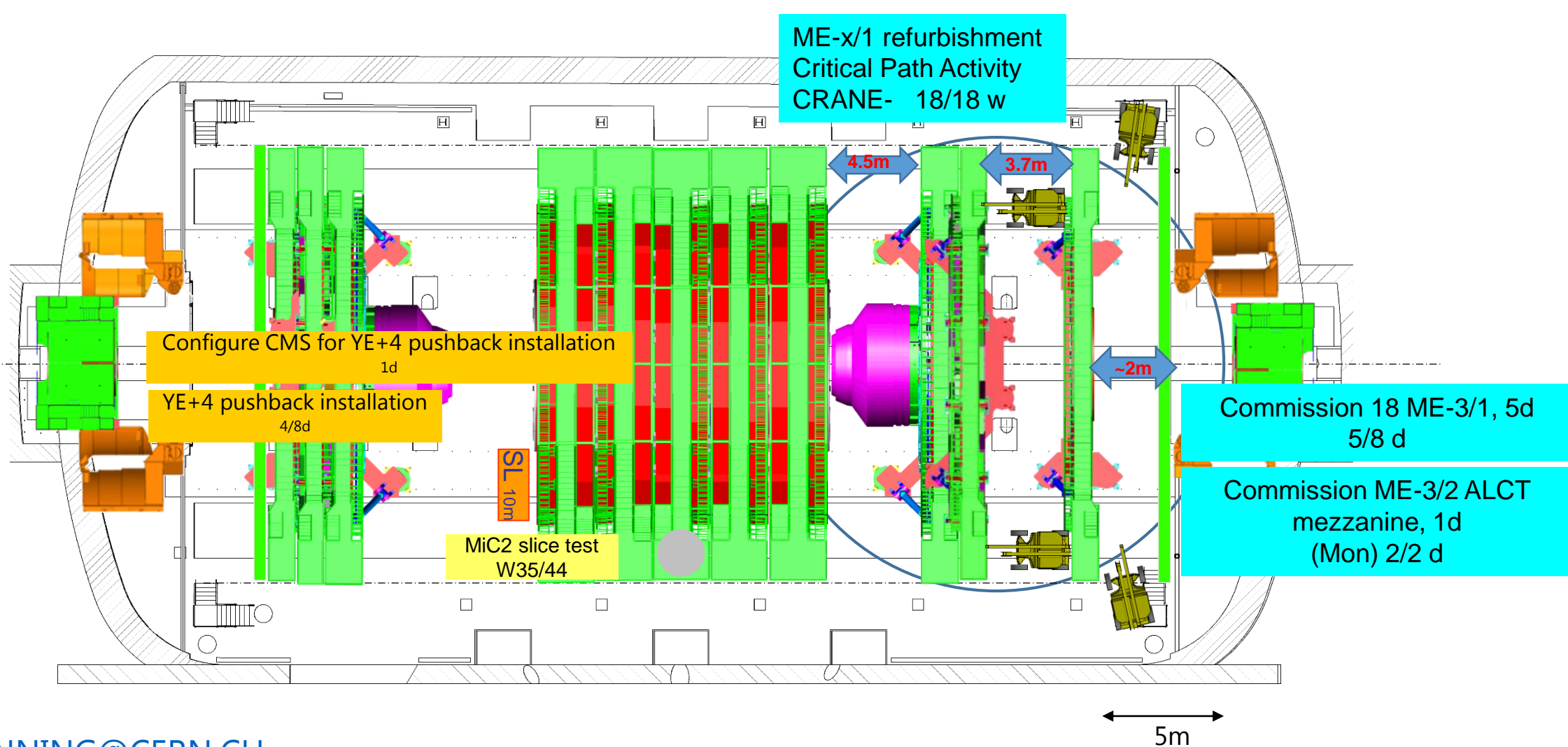
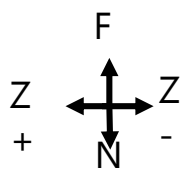



Crane

Cryo.	█	EL power	█	Water cool.	█	Database	█								
IT	█	Magnet	█	C6F14	█	Gas	█								
SL.	0	GEM	█	ECAL	█	ZEC	█	DT+ RB	█	Survey	█	TE-VSC	█	GS Dept	█
CP.	0	TOTEM	█	CMX	█	CSC RE	█	TK PIX	█	HCAL	█	EN Dept	█	RP	█

PX56 Plug CLOSED
TX54 Plug CLOSED

2020
June – Week 25

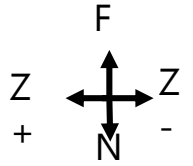

MUON work is over

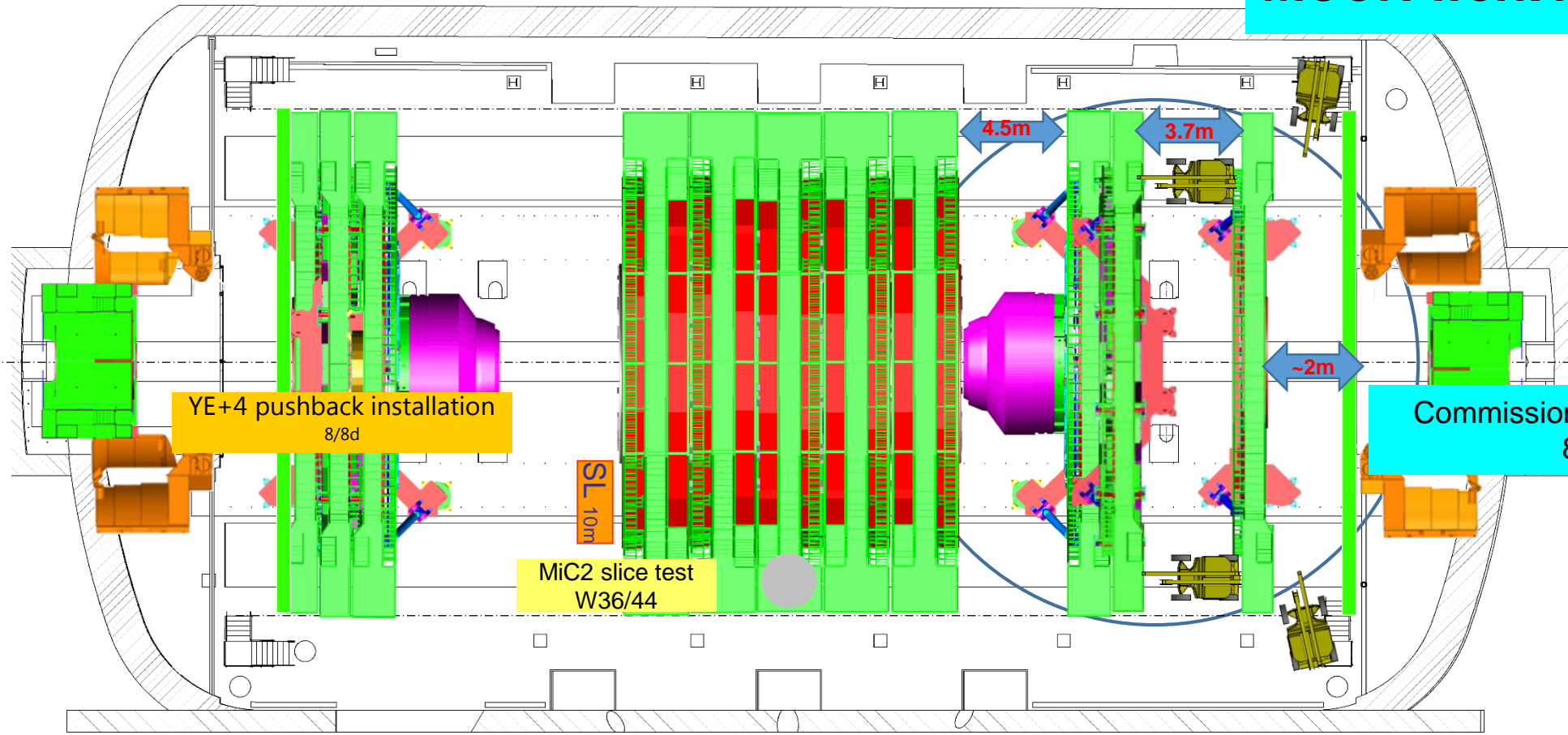

YE+4 pushback installation
8/8d

SL 10m

MiC2 slice test
W36/44

Commission 18 ME-3/1, 3d
8/8 d

5m



Crane

Cryo.		EL power		Water cool.		Database	
IT		Magnet		C6F14		Gas	
SL. 0							
CP. 0							

PX56 Plug CLOSED
TX54 Plug CLOSED

2020
June - Week 26

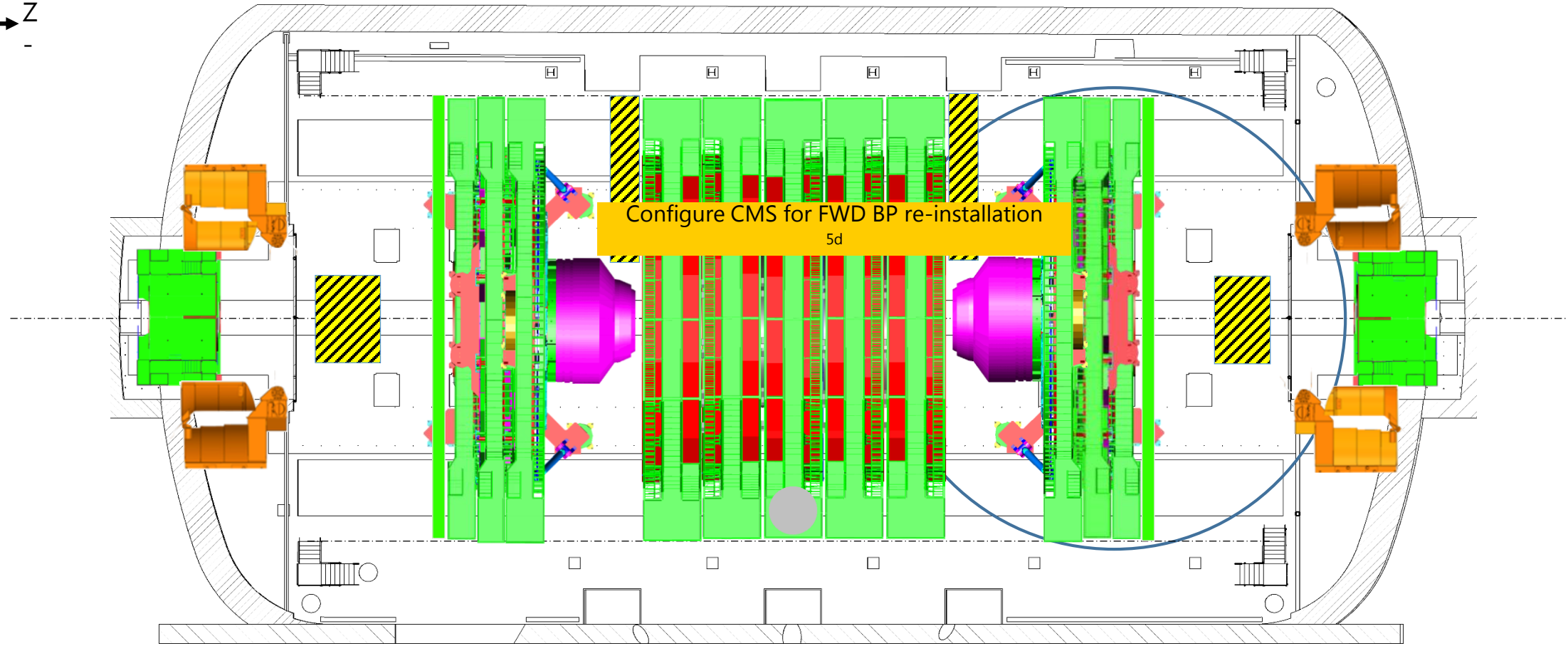
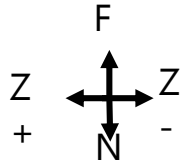

5m



Cryo.	█	EL power	█	Water cool.	█	Database	█
IT	█	Magnet	█	C6F14	█	Gas	█
SL. 0	GEM	ECAL	ZEC	DT+ RB	Survey	TE-VSC	GS Dept
CP. 0	TOTEM	CMX	CSC RE	TK PIX	HCAL	EN Dept	RP

PX56 Plug CLOSED	2020
TX54 Plug CLOSED	June - Week 27

Crane

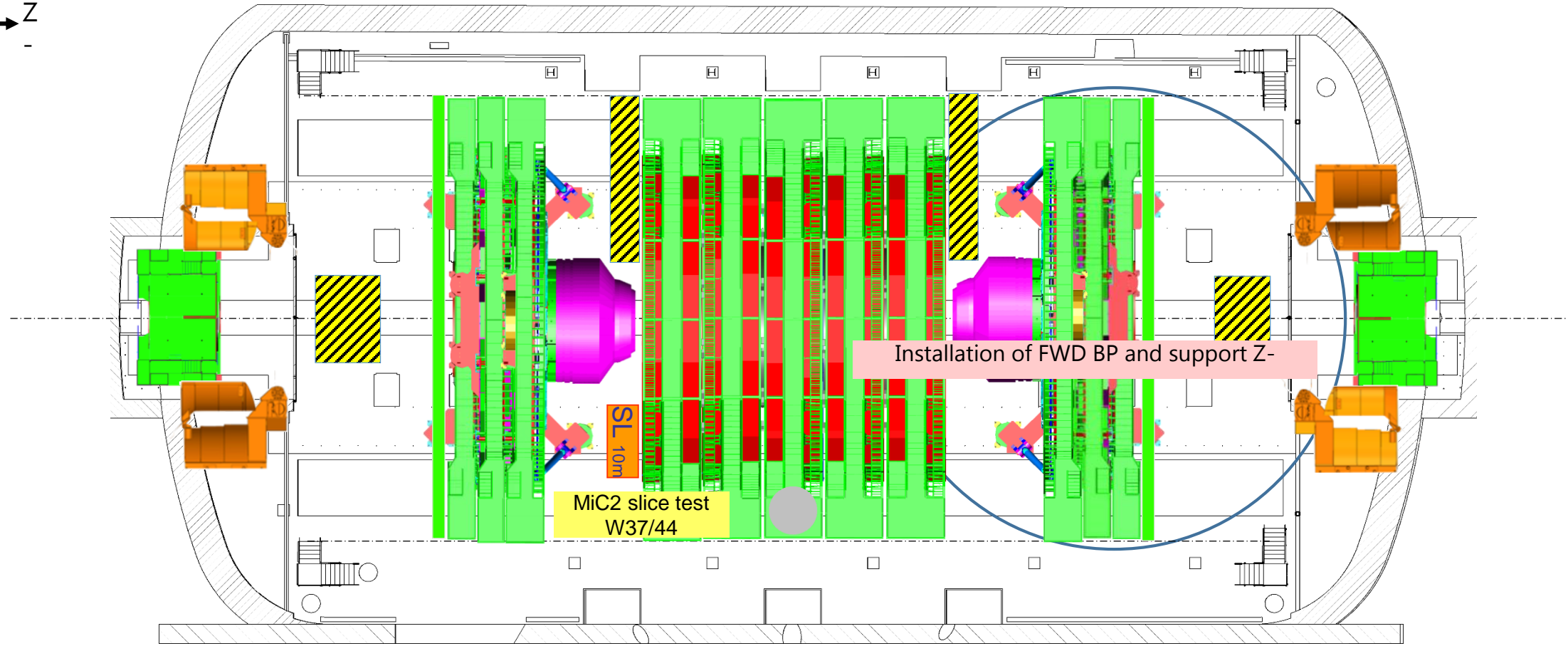
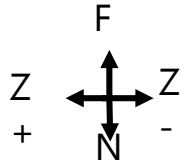



Crane

Cryo.	█	EL power	█	Water cool.	█	Database	█
IT	█	Magnet	█	C6F14	█	Gas	█
SL. 0	GEM	ECAL	ZEC	DT+ RB	Survey	TE-VSC	GS Dept
CP. 0	TOTEM	CMX	CSC RE	TK PIX	HCAL	EN Dept	RP

PX56 Plug CLOSED
TX54 Plug CLOSED

2020
July - Week 28

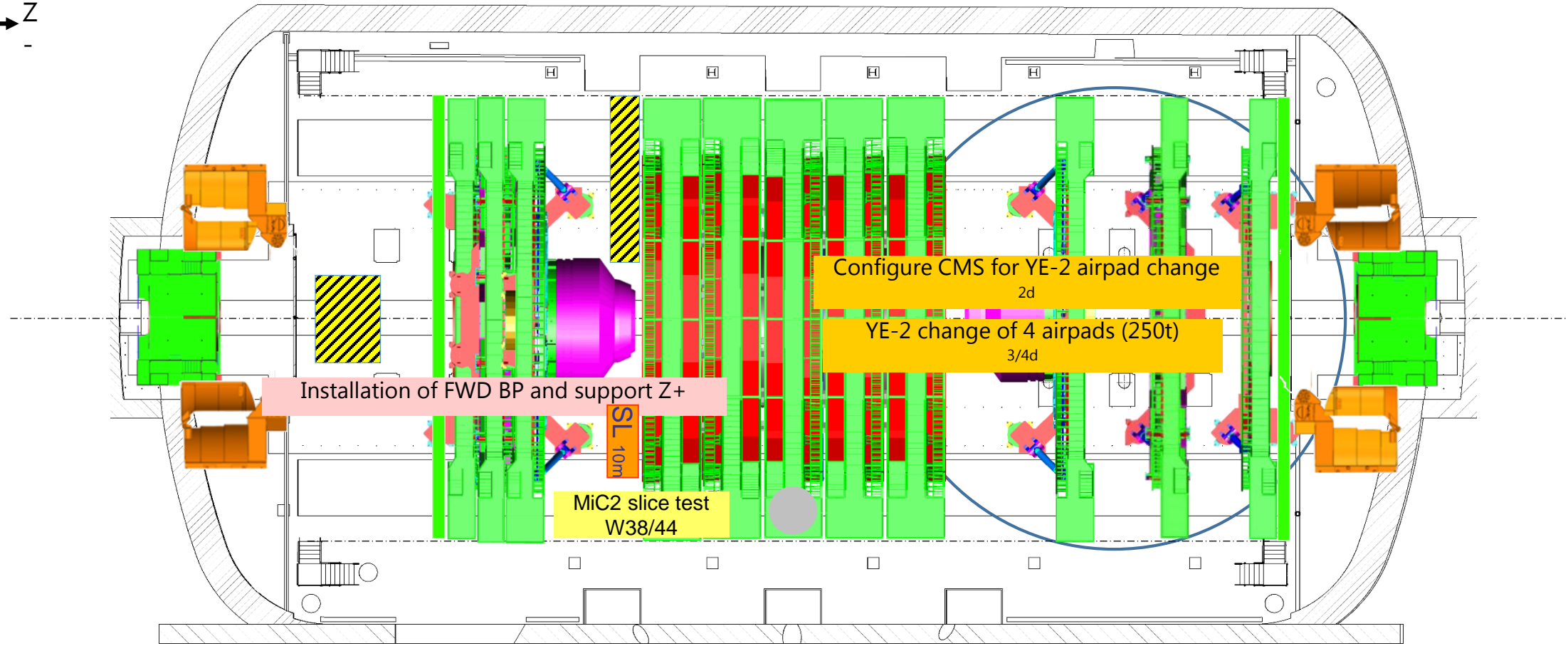
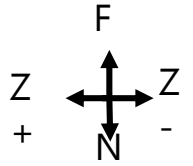



Crane

Cryo.	<input type="checkbox"/>	EL power	<input type="checkbox"/>	Water cool.	<input type="checkbox"/>	Database	<input type="checkbox"/>	
IT	<input type="checkbox"/>	Magnet	<input type="checkbox"/>	C6F14	<input type="checkbox"/>	Gas	<input type="checkbox"/>	
SL.	0	GEM	ECAL	ZEC	DT+ RB	Survey	TE-VSC	GS Dept
CP.	0	TOTEM	CMX	CSC RE	TK PIX	HCAL	EN Dept	RP

PX56 Plug CLOSED
TX54 Plug CLOSED

2020
July - Week 29

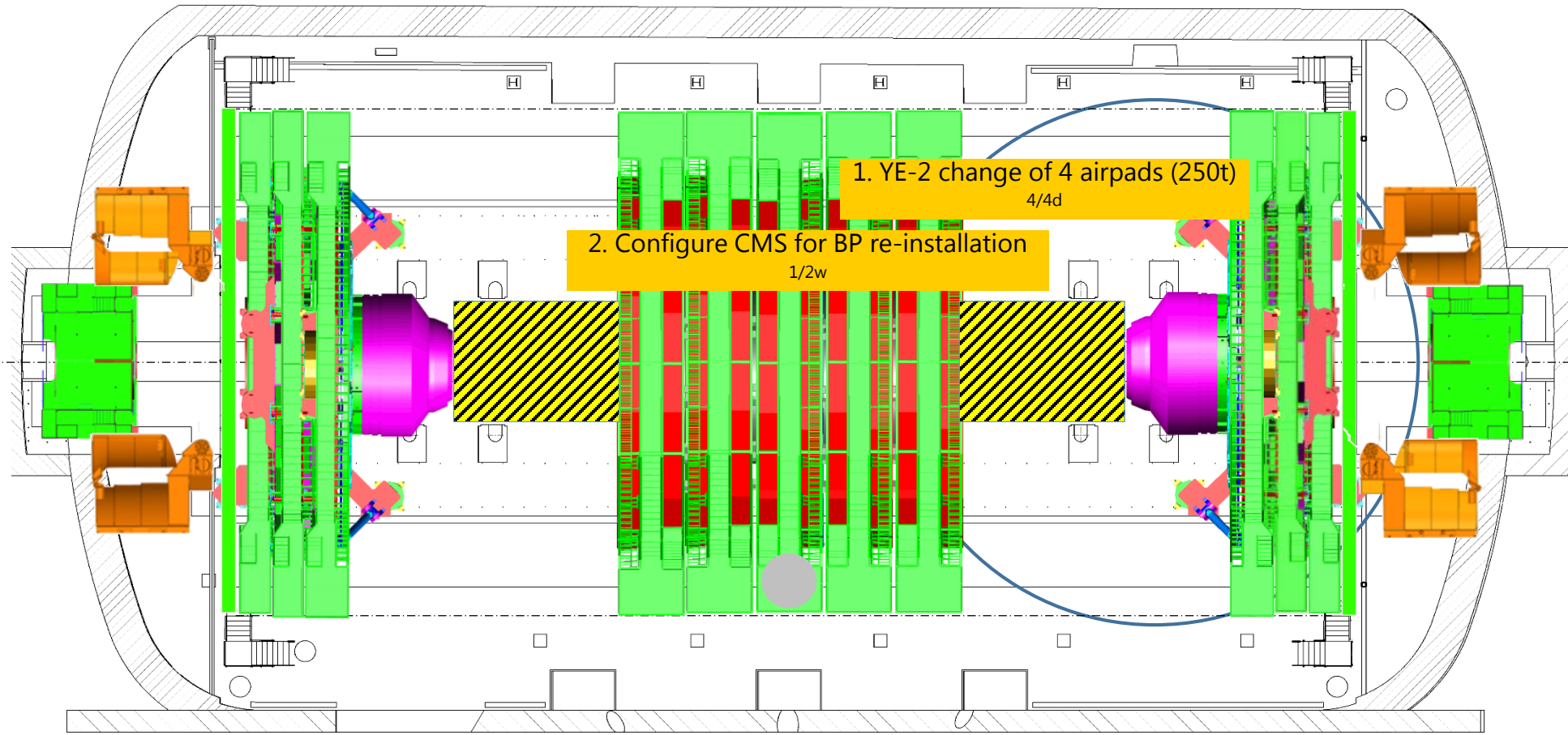
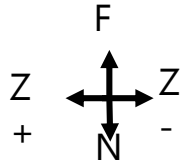

5m



Crane

Cryo.	<input type="checkbox"/>	EL power	<input type="checkbox"/>	Water cool.	<input type="checkbox"/>	Database	<input type="checkbox"/>
IT	<input type="checkbox"/>	Magnet	<input type="checkbox"/>	C6F14	<input type="checkbox"/>	Gas	<input type="checkbox"/>
SL. 0	GEM	ECAL	ZEC	DT+ RB	Survey	TE-VSC	GS Dept
CP. 0	TOTEM	CMX	CSC RE	TK PIX	HCAL	EN Dept	RP

PX56 Plug CLOSED
TX54 Plug CLOSED

2020
July - Week 30

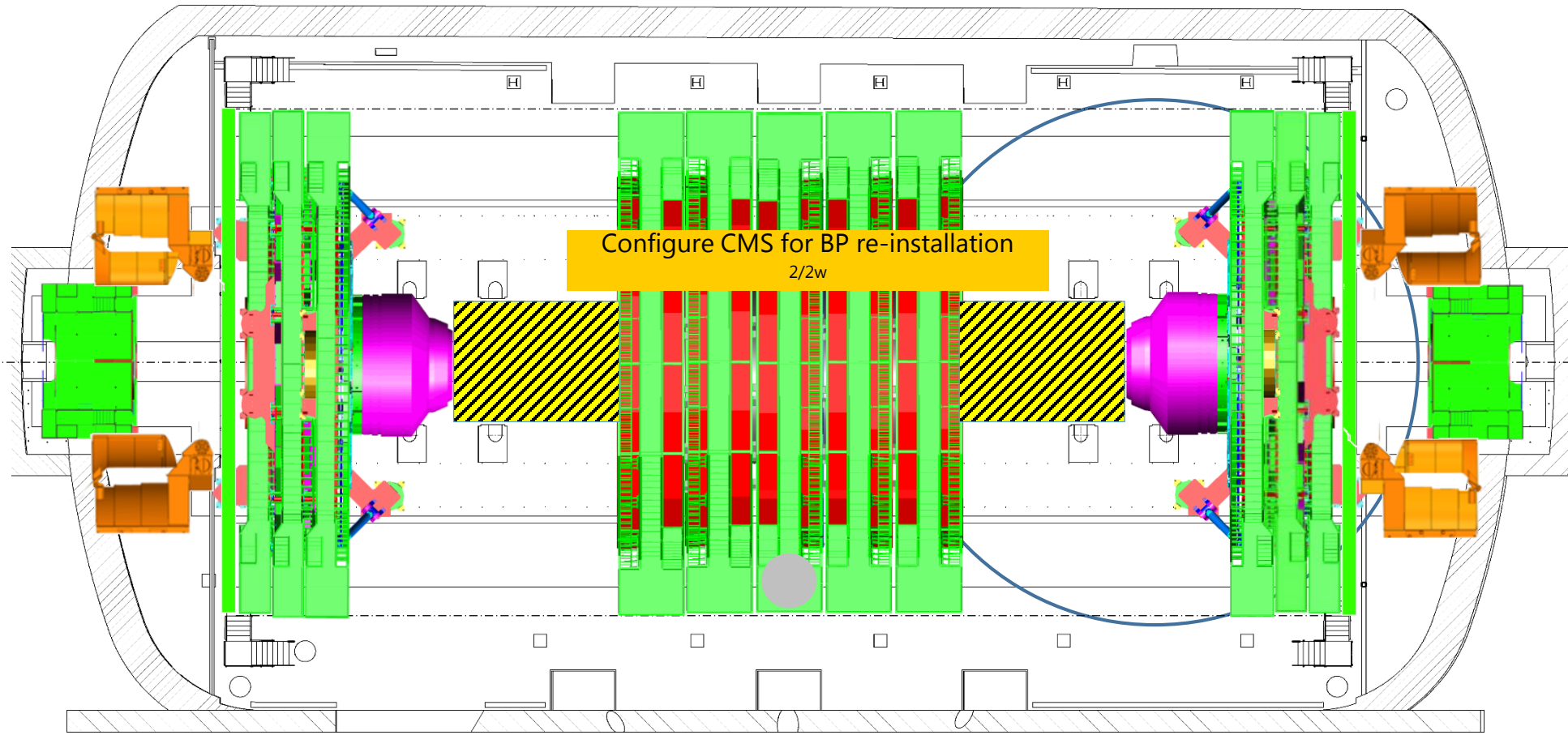
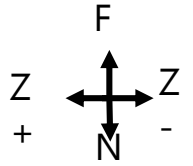

Configure CMS for BP re-installation
2/2w

5m



Crane

Cryo.	█	EL power	█	Water cool.	█	Database	█
IT	█	Magnet	█	C6F14	█	Gas	█
SL. 0	GEM	ECAL	ZEC	DT+ RB	Survey	TE-VSC	GS Dept
CP. 0	TOTEM	CMX	CSC RE	TK PIX	HCAL	EN Dept	RP

PX56 Plug CLOSED
TX54 Plug CLOSED

2020
July - Week 31

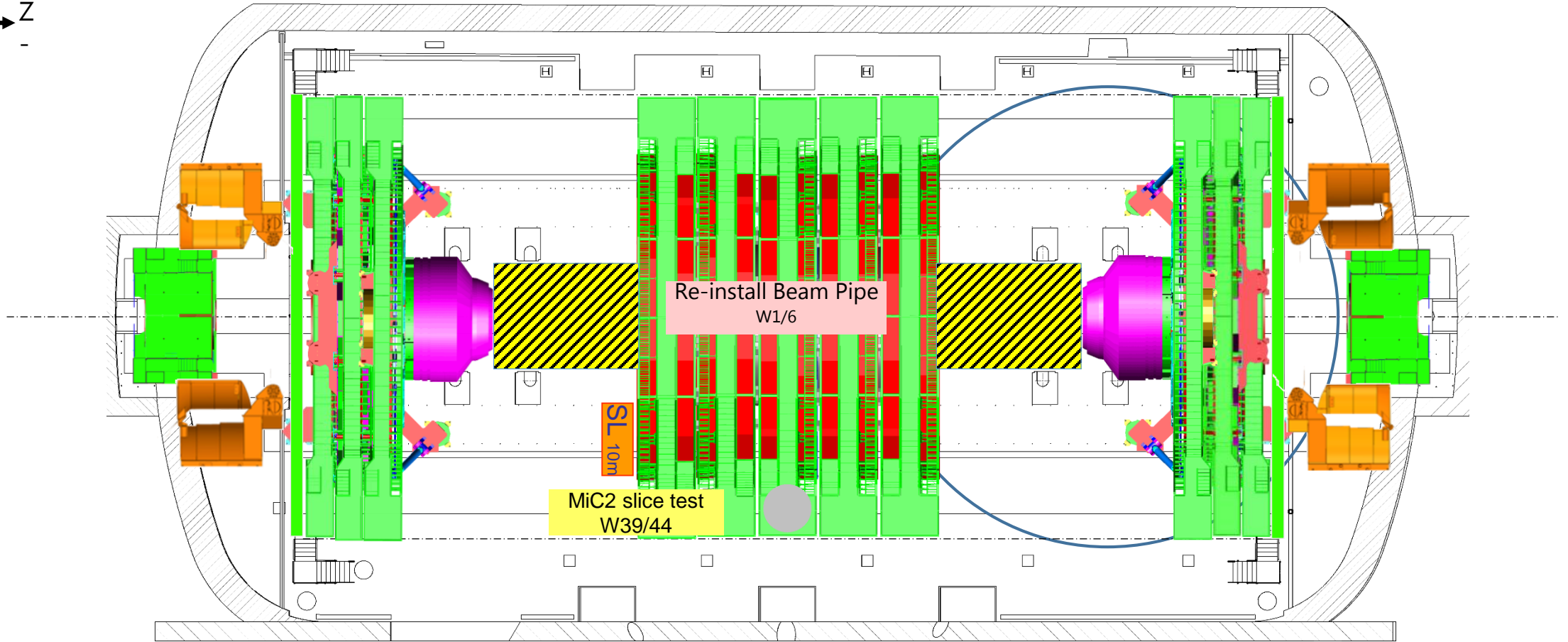
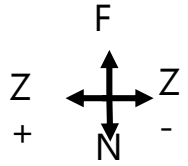



Crane

Cryo.	■	EL power	■	Water cool.	■	Database	■
IT	■	Magnet	■	C6F14	■	Gas	■
SL. 0	GEM	ECAL	ZEC	DT+ RB	Survey	TE-VSC	GS Dept
CP. 0	TOTEM	CMX	CSC RE	TK PIX	HCAL	EN Dept	RP

PX56 Plug
CLOSED

TX54 Plug
CLOSED

2020

August - Week 32

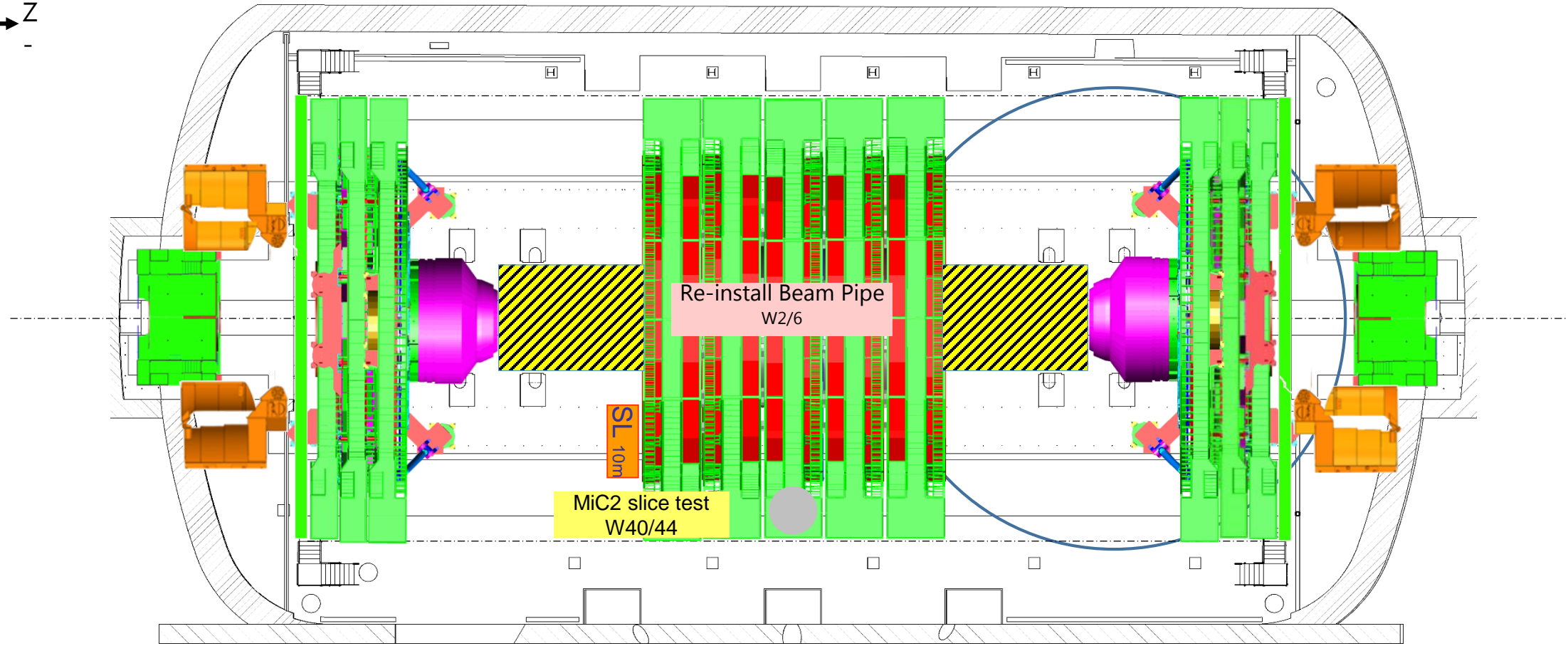
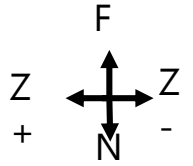

5m



Crane

Cryo.	█	EL power	█	Water cool.	█	Database	█
IT	█	Magnet	█	C6F14	█	Gas	█
SL. 0	GEM	ECAL	ZEC	DT+ RB	Survey	TE-VSC	GS Dept
CP. 0	TOTEM	CMX	CSC RE	TK PIX	HCAL	EN Dept	RP

PX56 Plug
CLOSED

TX54 Plug
CLOSED

2020

August - Week 33

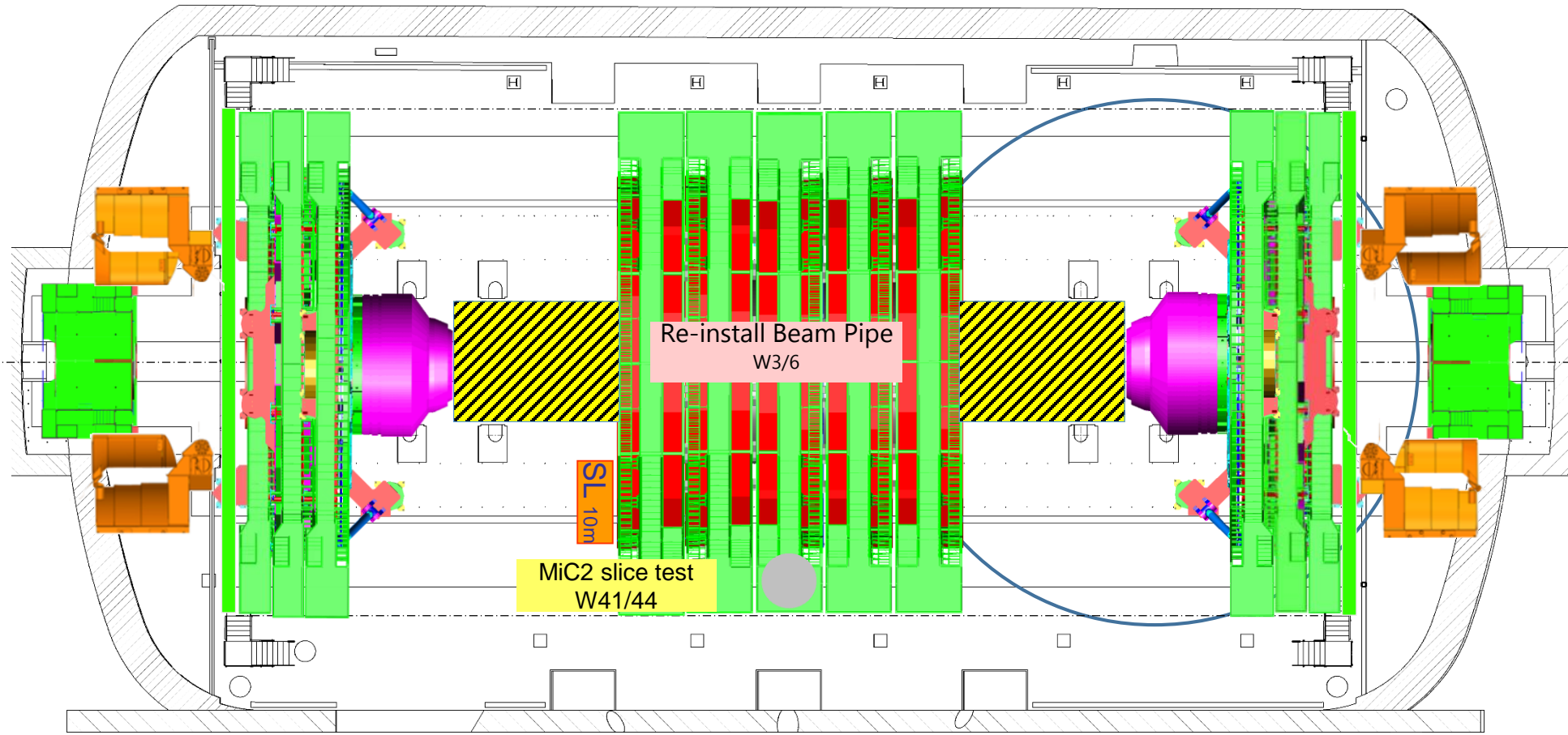
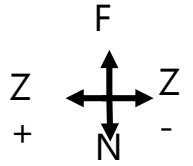

5m



Crane

Cryo.	█	EL power	█	Water cool.	█	Database	█
IT	█	Magnet	█	C6F14	█	Gas	█
SL. 0	GEM	ECAL	ZEC	DT+ RB	Survey	TE-VSC	GS Dept
CP. 0	TOTEM	CMX	CSC RE	TK PIX	HCAL	EN Dept	RP

PX56 Plug
CLOSED

TX54 Plug
CLOSED

2020

August - Week 34

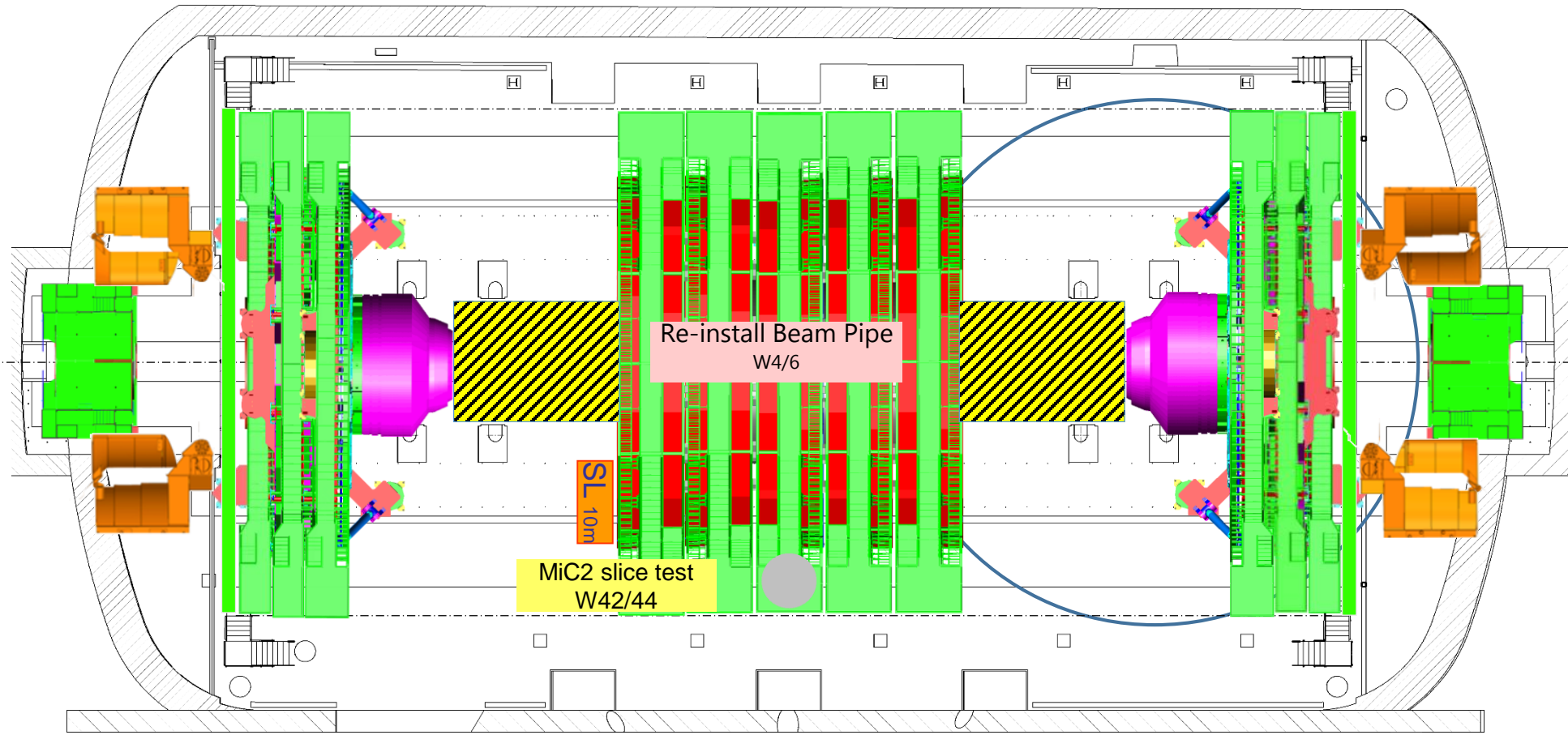
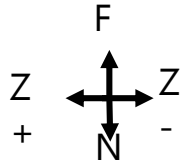

SL 10m

MiC2 slice test
W42/44

Re-install Beam Pipe
W4/6

5m



Crane

Cryo.	█	EL power	█	Water cool.	█	Database	█
IT	█	Magnet	█	C6F14	█	Gas	█
SL. 0	GEM	ECAL	ZEC	DT+ RB	Survey	TE-VSC	GS Dept
CP. 0	TOTEM	CMX	CSC RE	TK PIX	HCAL	EN Dept	RP

PX56 Plug CLOSED
TX54 Plug CLOSED

2020
August - Week 35

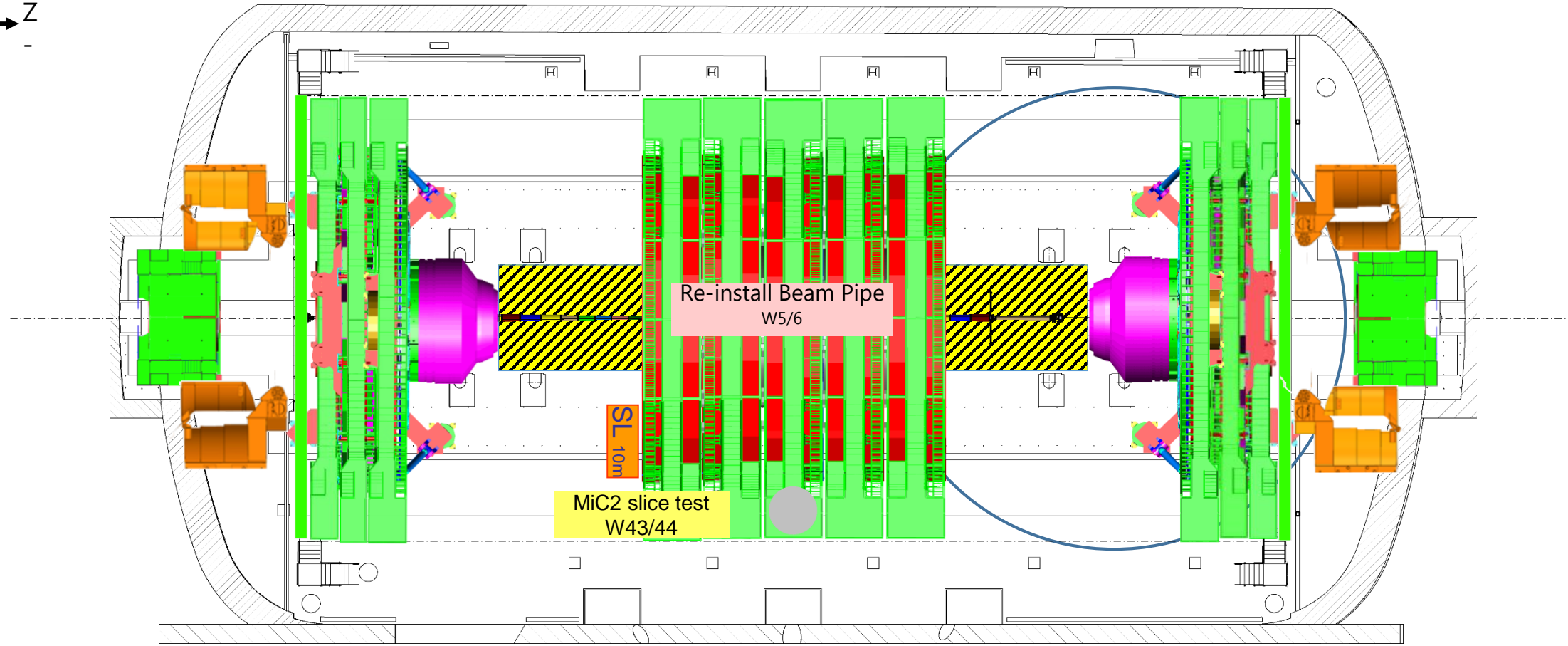
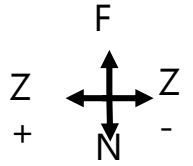

5m



Cryo.	█	EL power	█	Water cool.	█	Database	█
IT	█	Magnet	█	C6F14	█	Gas	█
SL. 0	GEM	ECAL	ZEC	DT+ RB	Survey	TE-VSC	GS Dept
CP. 0	TOTEM	CMX	CSC RE	TK PIX	HCAL	EN Dept	RP

PX56 Plug
CLOSED

TX54 Plug
CLOSED

2020

August - Week 36

Crane

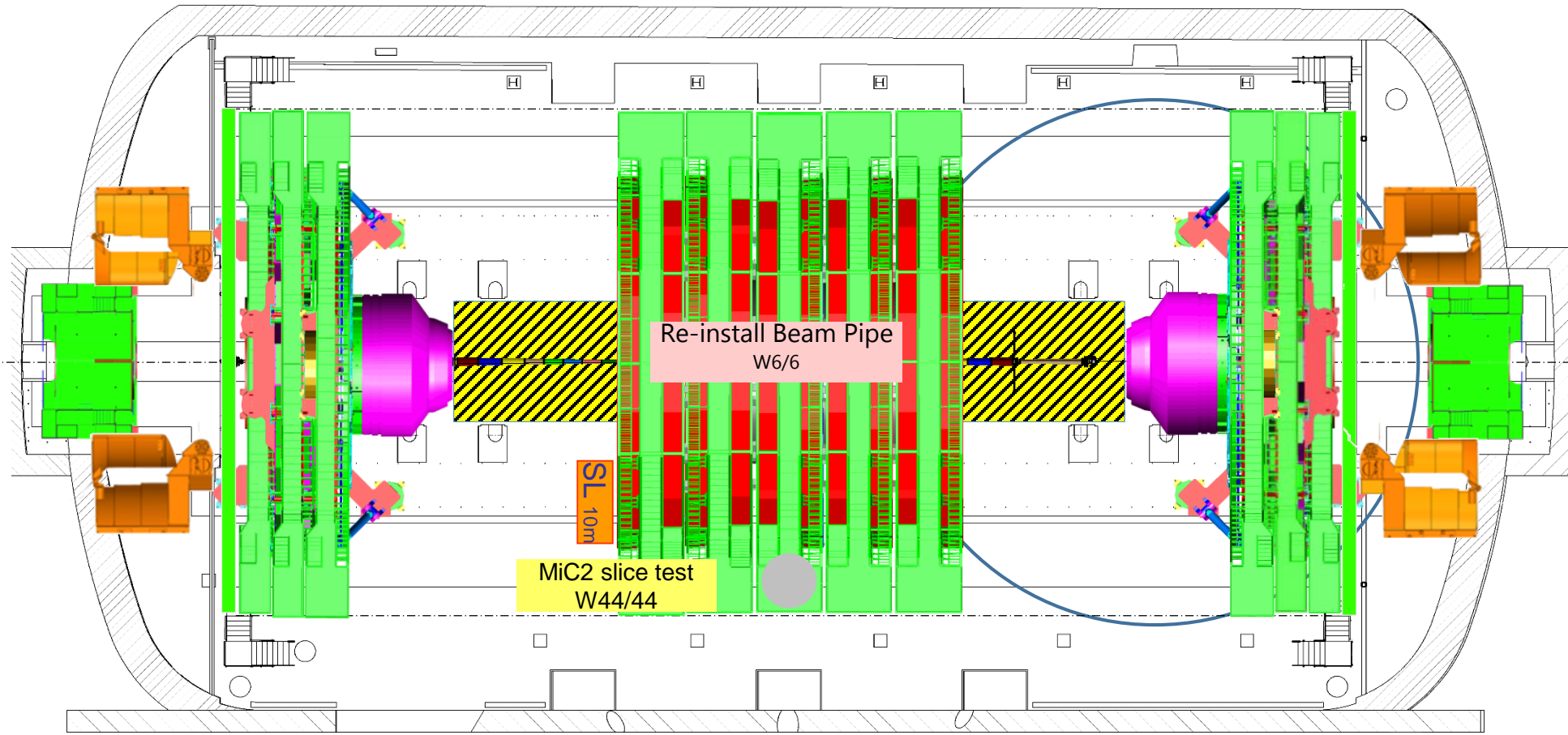
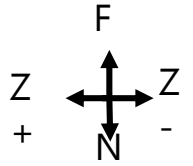

5m



Crane

Cryo.	█	EL power	█	Water cool.	█	Database	█
IT	█	Magnet	█	C6F14	█	Gas	█
SL. 0	GEM	ECAL	ZEC	DT+ RB	Survey	TE-VSC	GS Dept
CP. 0	TOTEM	CMX	CSC RE	TK PIX	HCAL	EN Dept	RP

PX56 Plug CLOSED
TX54 Plug CLOSED

2020
September - Week 37

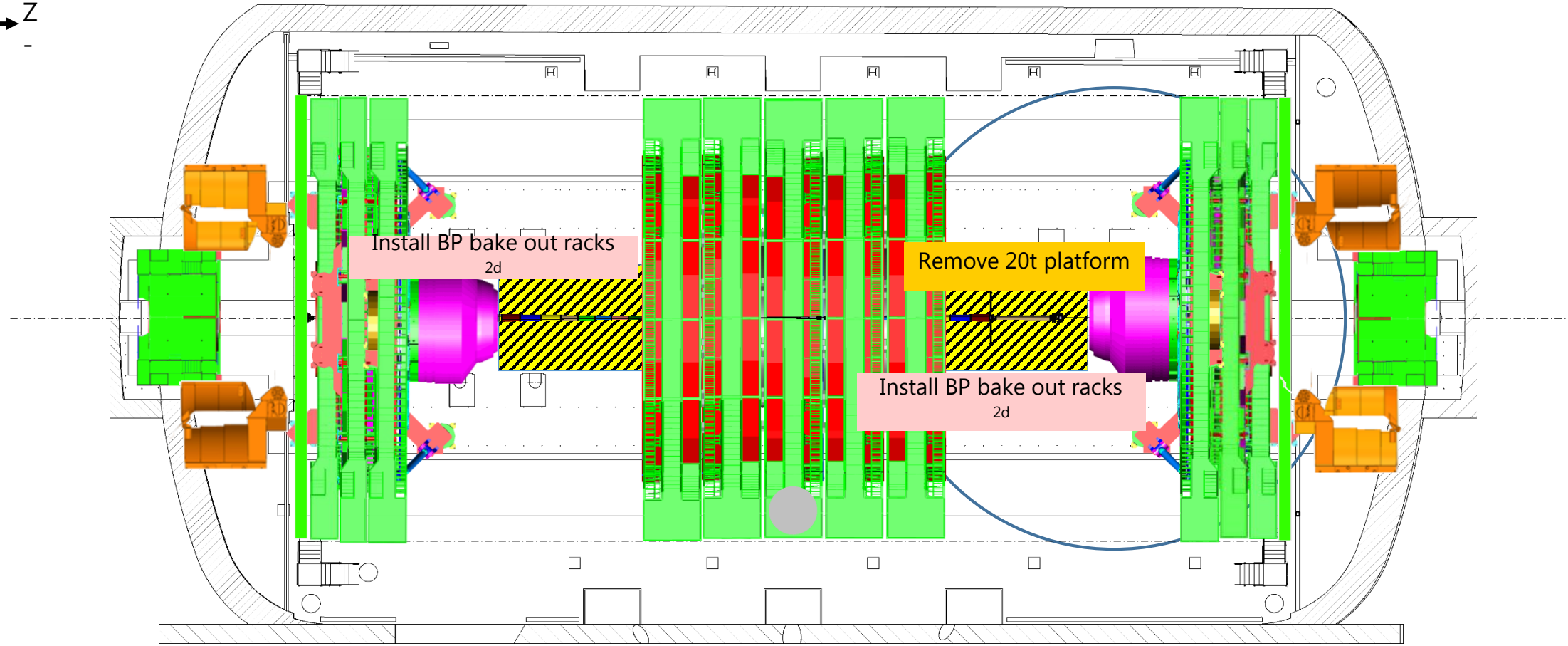
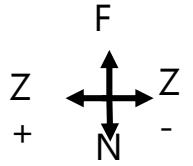

5m



Cryo.	█	EL power	█	Water cool.	█	Database	█
IT	█	Magnet	█	C6F14	█	Gas	█
SL. 0	GEM	ECAL	ZEC	DT+ RB	Survey	TE-VSC	GS Dept
CP. 0	TOTEM	CMX	CSC RE	TK PIX	HCAL	EN Dept	RP

PX56 Plug CLOSED	2020
TX54 Plug CLOSED	September - Week 38

Crane

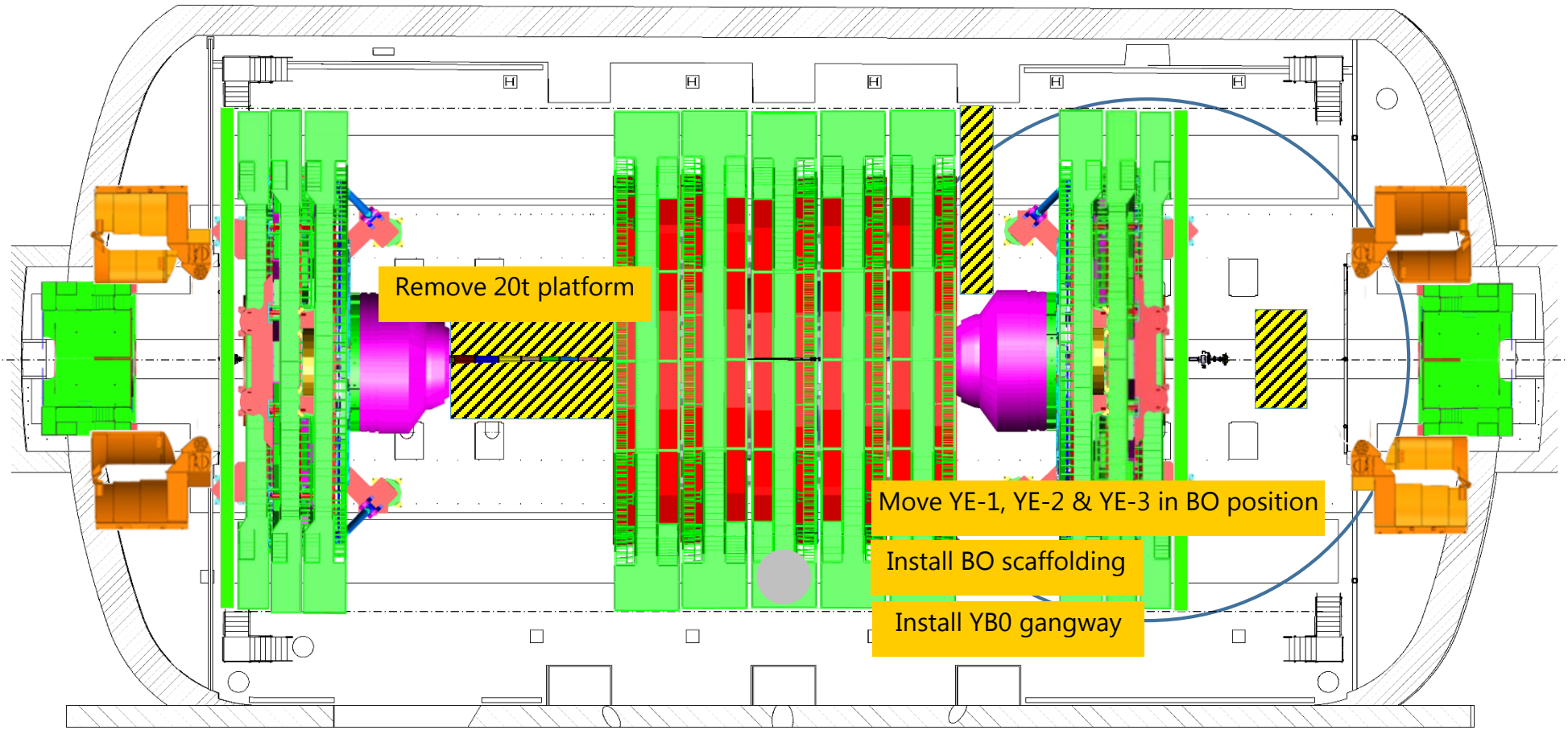
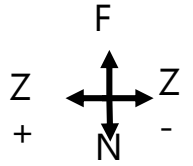

5m



Cryo.	█	EL power	█	Water cool.	█	Database	█
IT	█	Magnet	█	C6F14	█	Gas	█
SL. 0	GEM	ECAL	ZEC	DT+ RB	Survey	TE-VSC	GS Dept
CP. 0	TOTEM	CMX	CSC RE	TK PIX	HCAL	EN Dept	RP

PX56 Plug CLOSED

2020

TX54 Plug CLOSED

September - Week 39

Crane

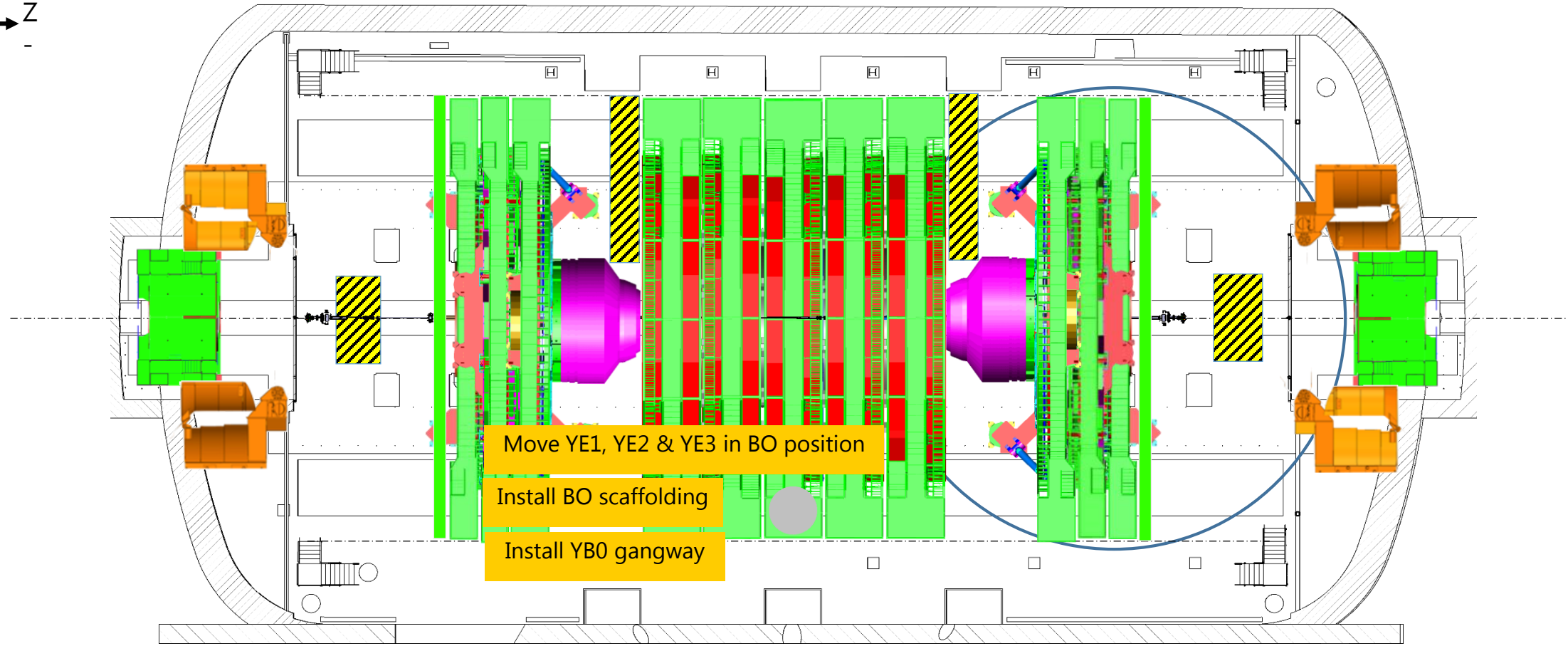
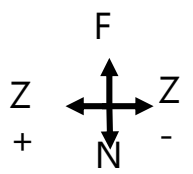

5m



Crane

Cryo.	█	EL power	█	Water cool.	█	Database	█
IT	█	Magnet	█	C6F14	█	Gas	█
SL. 0	GEM	ECAL	ZEC	DT+ RB	Survey	TE-VSC	GS Dept
CP. 0	TOTEM	CMX	CSC RE	TK PIX	HCAL	EN Dept	RP

PX56 Plug CLOSED
TX54 Plug CLOSED

2020
September - Week 40

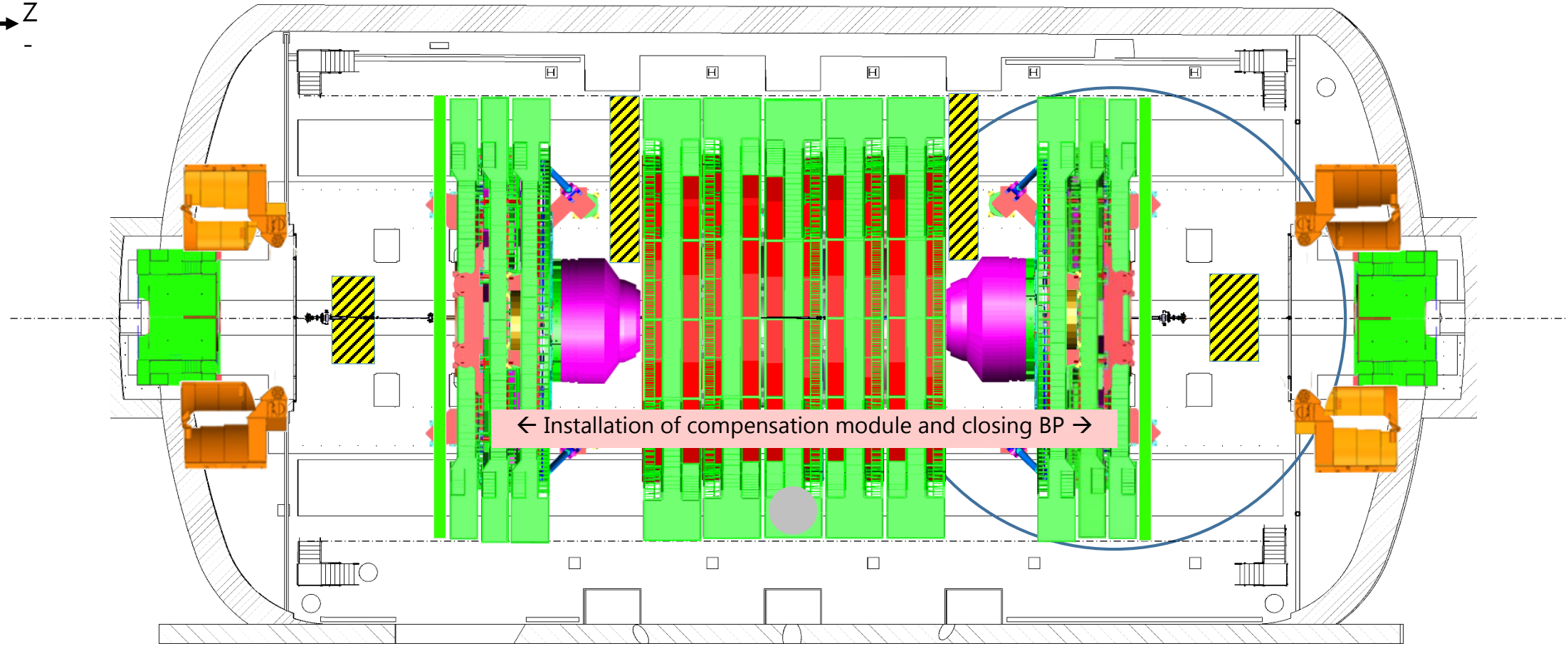
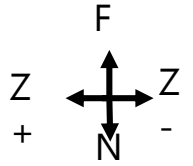

← Installation of compensation module and closing BP →

5m



Crane

Cryo.	■	EL power	■	Water cool.	■	Database	■
IT	■	Magnet	■	C6F14	■	Gas	■
SL. 0	GEM	ECAL	ZEC	DT+ RB	Survey	TE-VSC	GS Dept
CP. 0	TOTEM	CMX	CSC RE	TK PIX	HCAL	EN Dept	RP

PX56 Plug CLOSED
TX54 Plug CLOSED

2020
October - Week 41

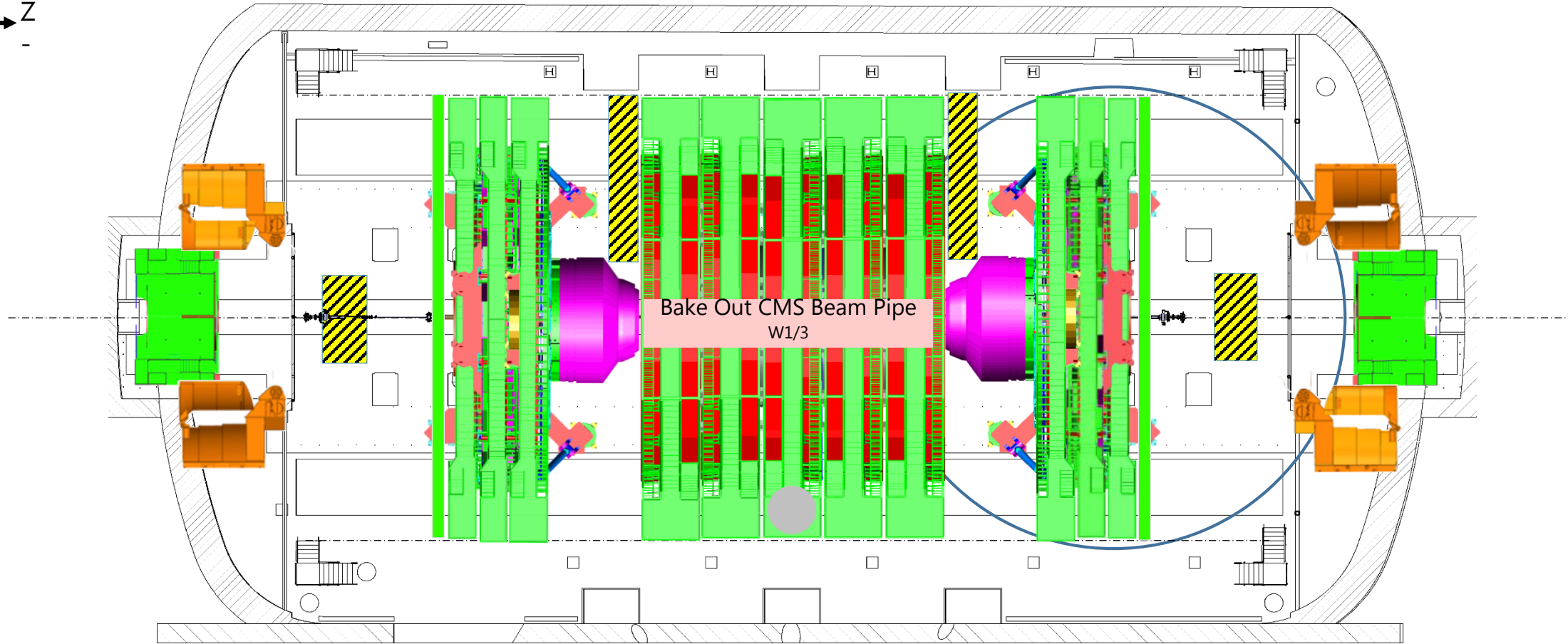
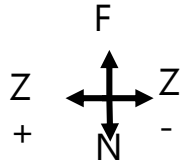

5m



Crane

Cryo.	█	EL power	█	Water cool.	█	Database	█
IT	█	Magnet	█	C6F14	█	Gas	█
SL. 0	GEM	ECAL	ZEC	DT+ RB	Survey	TE-VSC	GS Dept
CP. 0	TOTEM	CMX	CSC RE	TK PIX	HCAL	EN Dept	RP

PX56 Plug
CLOSED

TX54 Plug
CLOSED

2020

October - Week 42

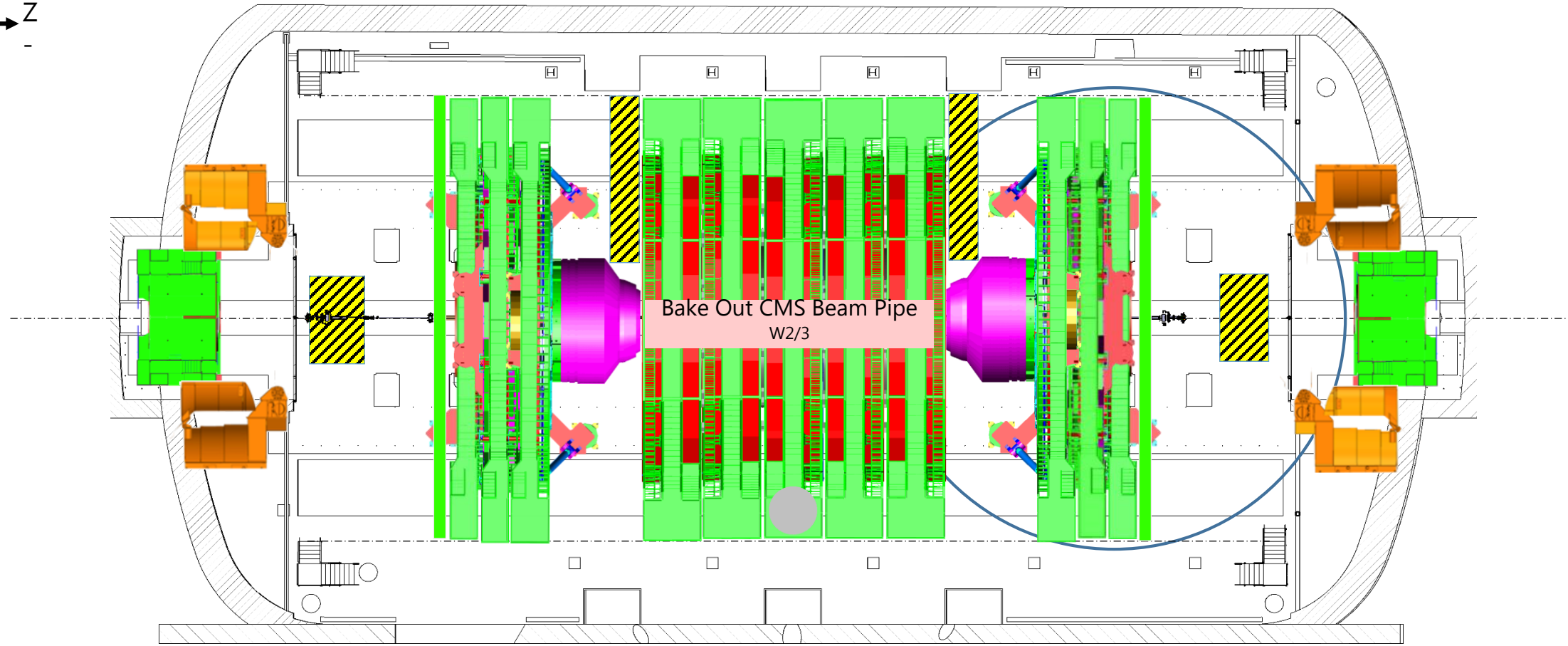
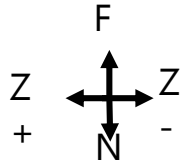

5m



Crane

Cryo.	█	EL power	█	Water cool.	█	Database	█
IT	█	Magnet	█	C6F14	█	Gas	█
SL. 0	GEM	ECAL	ZEC	DT+ RB	Survey	TE-VSC	GS Dept
CP. 0	TOTEM	CMX	CSC RE	TK PIX	HCAL	EN Dept	RP

PX56 Plug CLOSED
TX54 Plug CLOSED

2020
October - Week 43

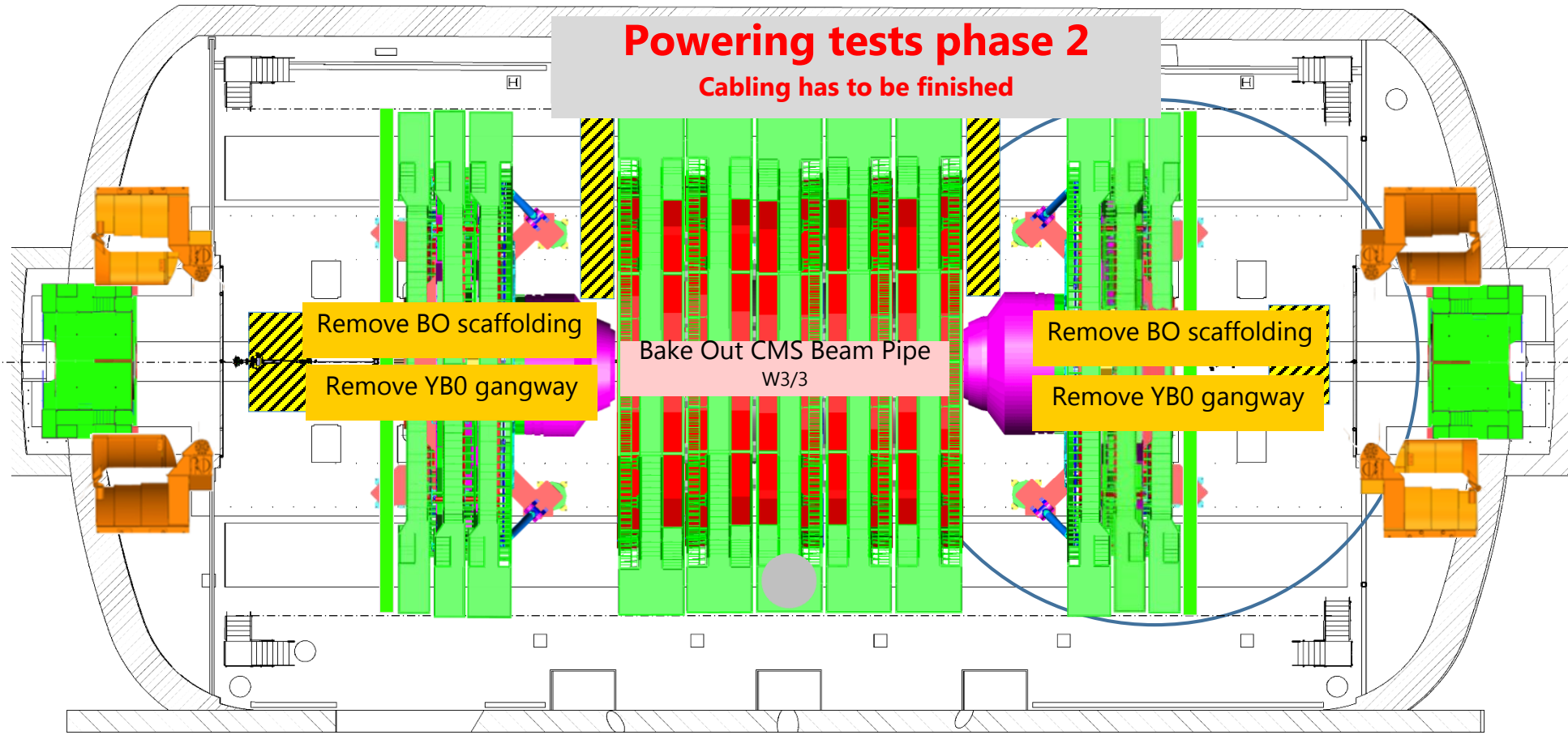
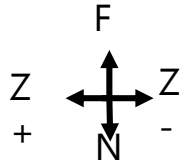

Powering tests phase 2
Cabling has to be finished

Remove BO scaffolding
Remove YB0 gangway

Bake Out CMS Beam Pipe
W3/3

Remove BO scaffolding
Remove YB0 gangway

5m



Cryo.	█	EL power	█	Water cool.	█	Database	█
IT	█	Magnet	█	C6F14	█	Gas	█
SL. 0	GEM	ECAL	ZEC	DT+ RB	Survey	TE-VSC	GS Dept
CP. 0	TOTEM	CMX	CSC RE	TK PIX	HCAL	EN Dept	RP

PX56 Plug
CLOSED

TX54 Plug
CLOSED

2020

October - Week 44

Crane

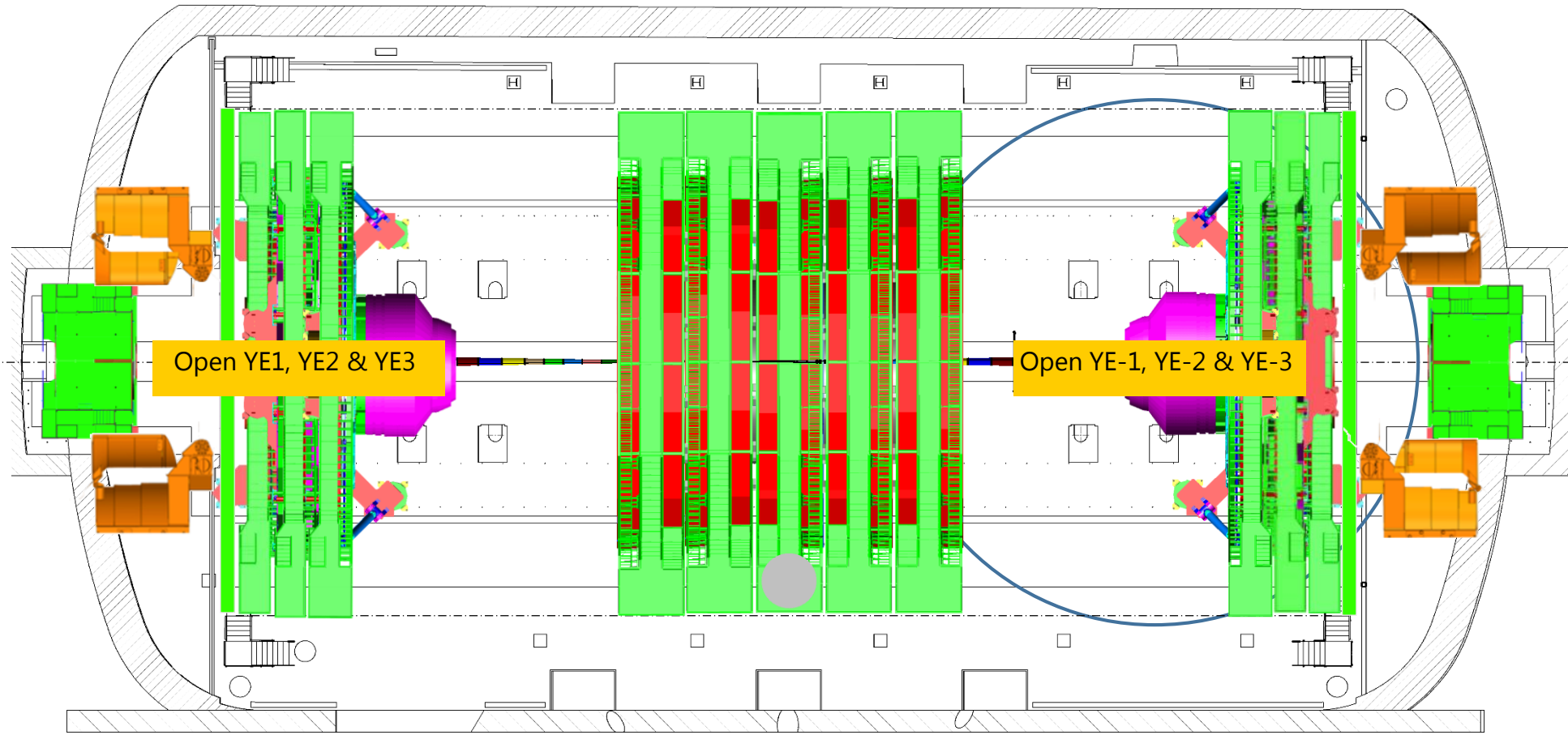
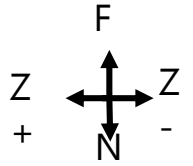

5m



Crane

Cryo.	█	EL power	█	Water cool.	█	Database	█
IT	█	Magnet	█	C6F14	█	Gas	█
SL. 0	GEM	ECAL	ZEC	DT+ RB	Survey	TE-VSC	GS Dept
CP. 0	TOTEM	CMX	CSC RE	TK PIX	HCAL	EN Dept	RP

PX56 Plug
CLOSED

TX54 Plug
CLOSED

2020

November - Week 45

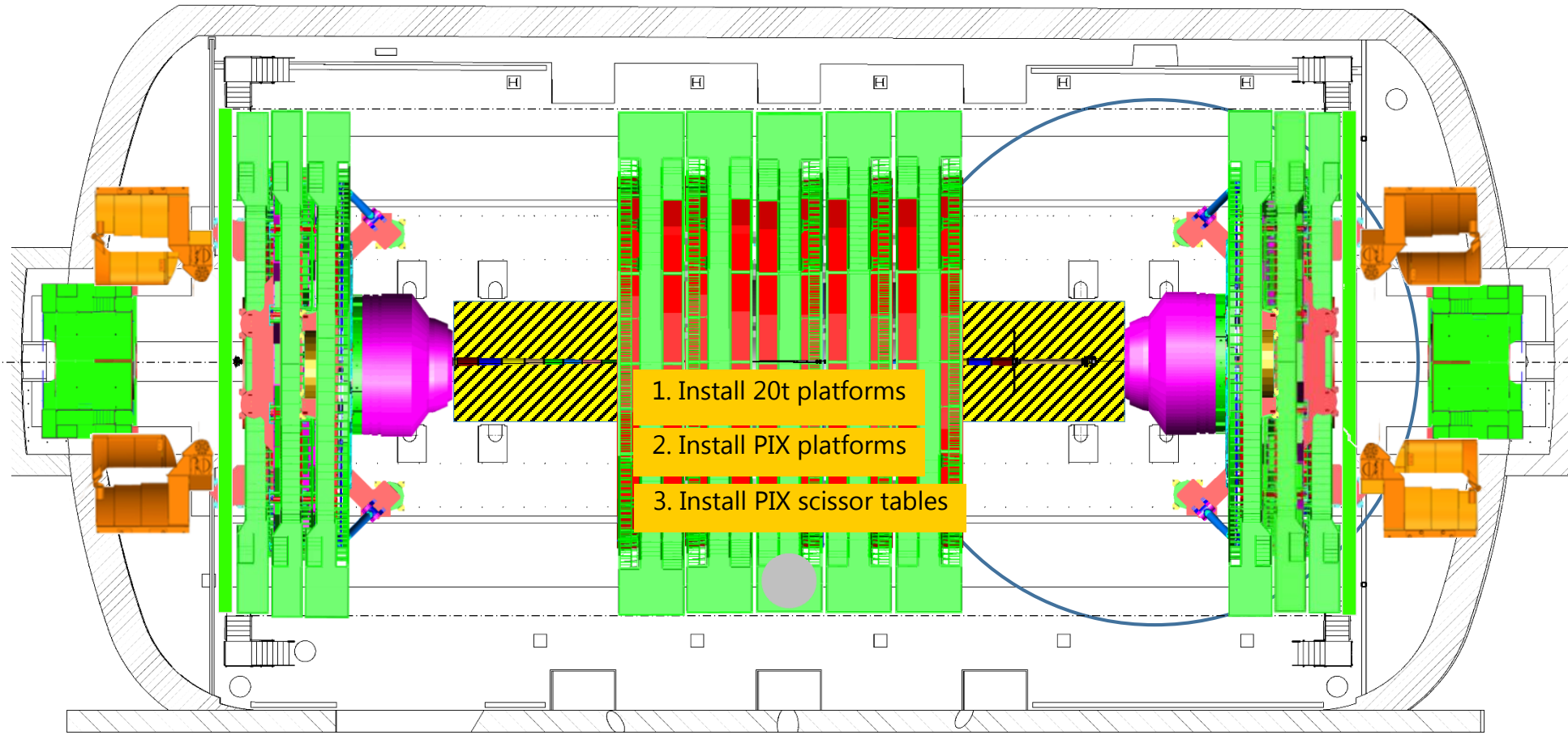
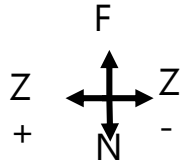

1. Install 20t platforms
2. Install PIX platforms
3. Install PIX scissor tables

5m



Crane

Cryo.	█	EL power	█	Water cool.	█	Database	█
IT	█	Magnet	█	C6F14	█	Gas	█
SL. 0	GEM	ECAL	ZEC	DT+ RB	Survey	TE-VSC	GS Dept
CP. 0	TOTEM	CMX	CSC RE	TK PIX	HCAL	EN Dept	RP

PX56 Plug
CLOSED

TX54 Plug
CLOSED

2020

November - Week 46

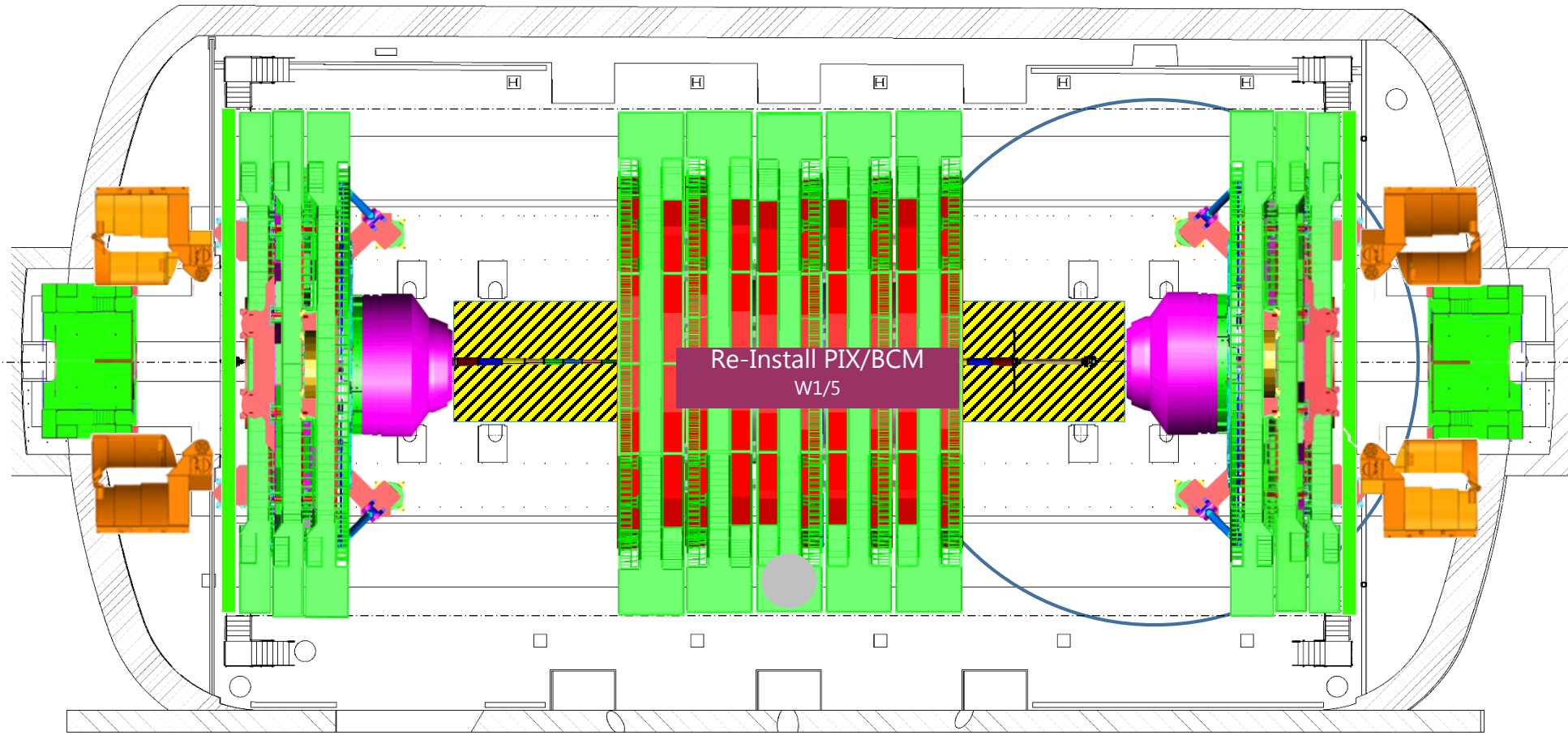
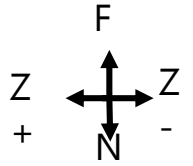

5m



Cryo.	█	EL power	█	Water cool.	█	Database	█
IT	█	Magnet	█	C6F14	█	Gas	█
SL. 0	GEM	ECAL	ZEC	DT+ RB	Survey	TE-VSC	GS Dept
CP. 0	TOTEM	CMX	CSC RE	TK PIX	HCAL	EN Dept	RP

PX56 Plug
CLOSED

TX54 Plug
CLOSED

2020

November - Week 47

Crane

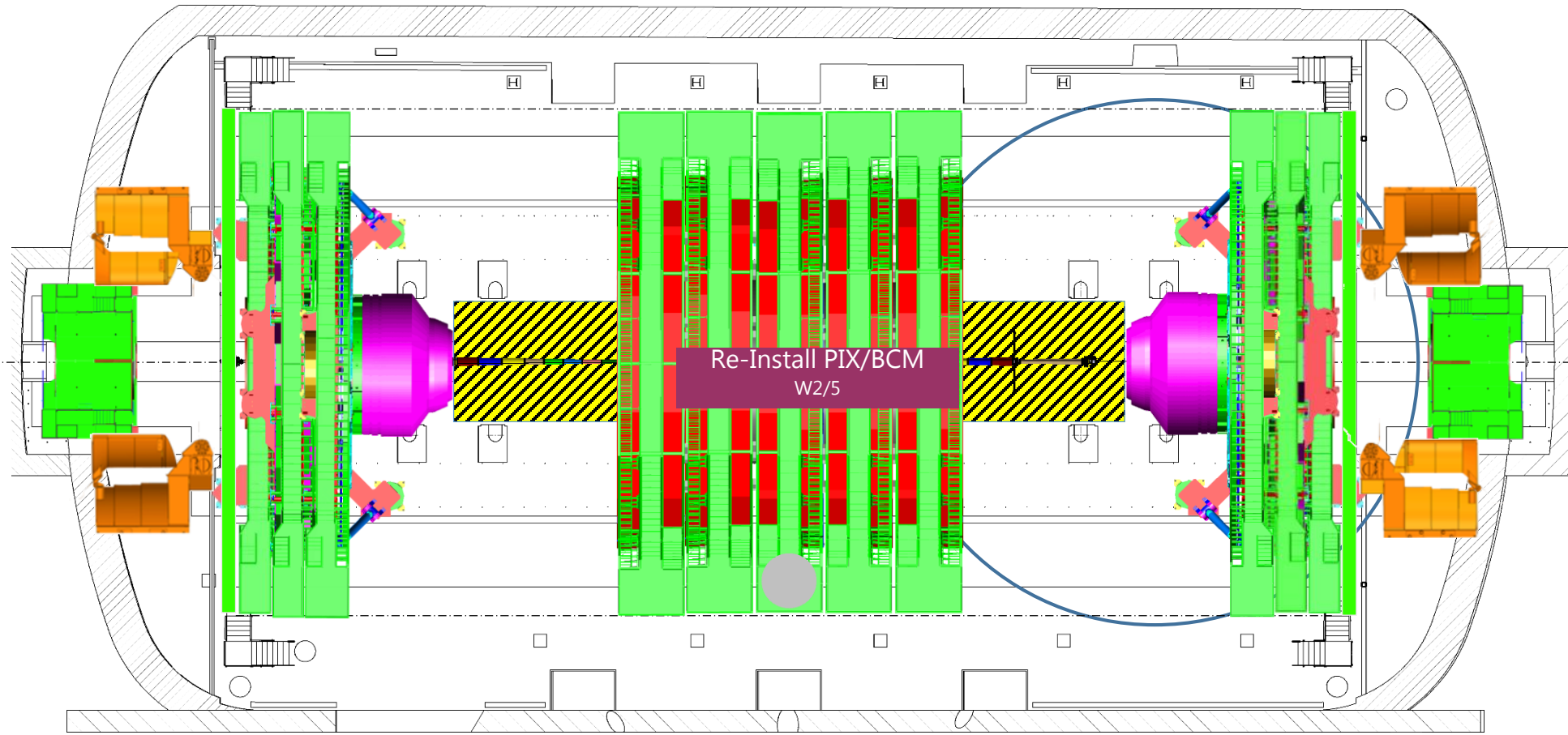
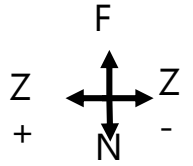

5m



Crane

Cryo.		EL power		Water cool.		Database	
IT		Magnet		C6F14		Gas	
SL. 0							
CP. 0							

PX56 Plug CLOSED
TX54 Plug CLOSED

2020
November - Week 48

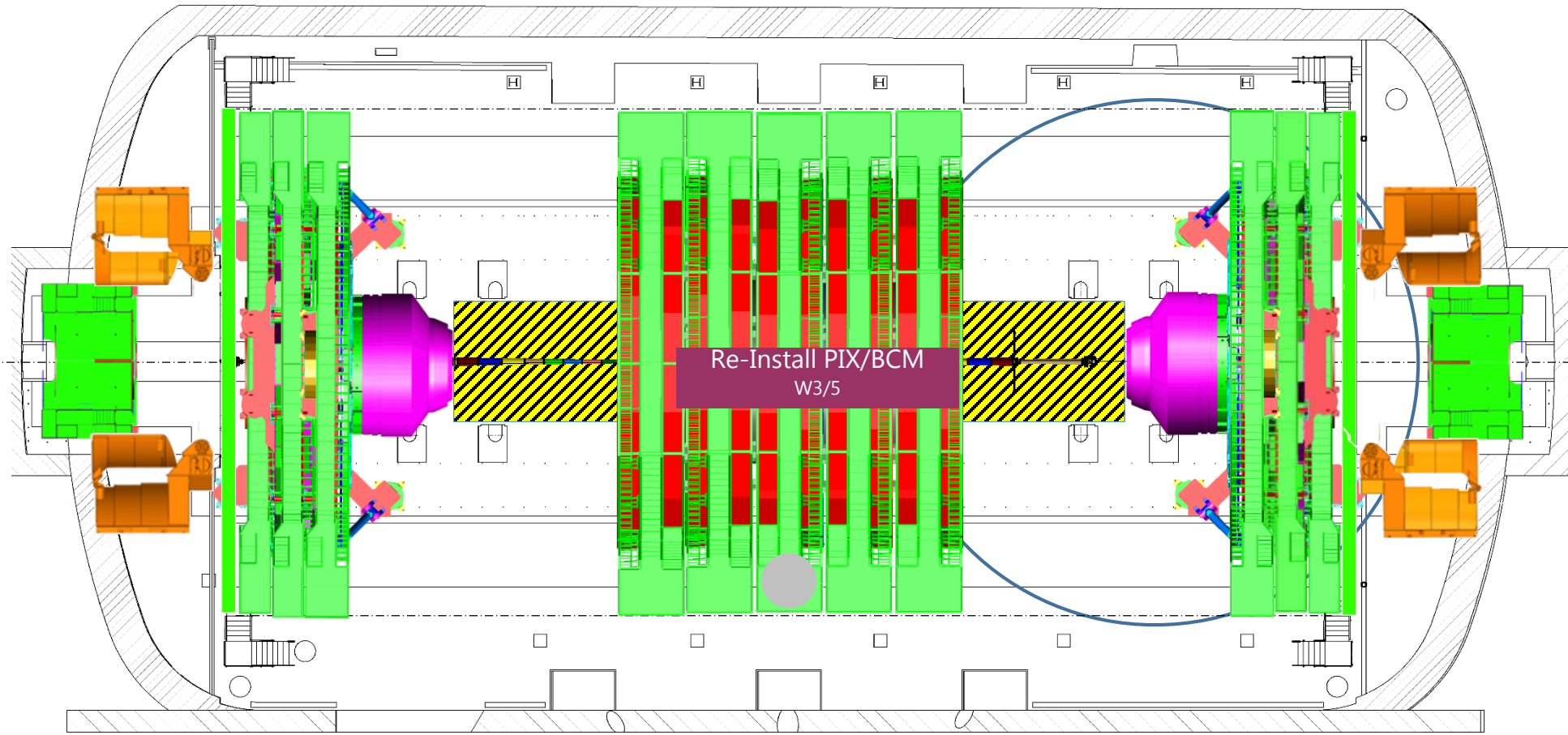
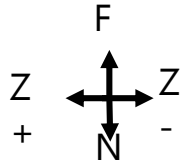

5m



Cryo.	█	EL power	█	Water cool.	█	Database	█
IT	█	Magnet	█	C6F14	█	Gas	█
SL. 0	GEM	ECAL	ZEC	DT+ RB	Survey	TE-VSC	GS Dept
CP. 0	TOTEM	CMX	CSC RE	TK PIX	HCAL	EN Dept	RP

PX56 Plug
CLOSED

TX54 Plug
CLOSED

2020

November - Week 49

Crane

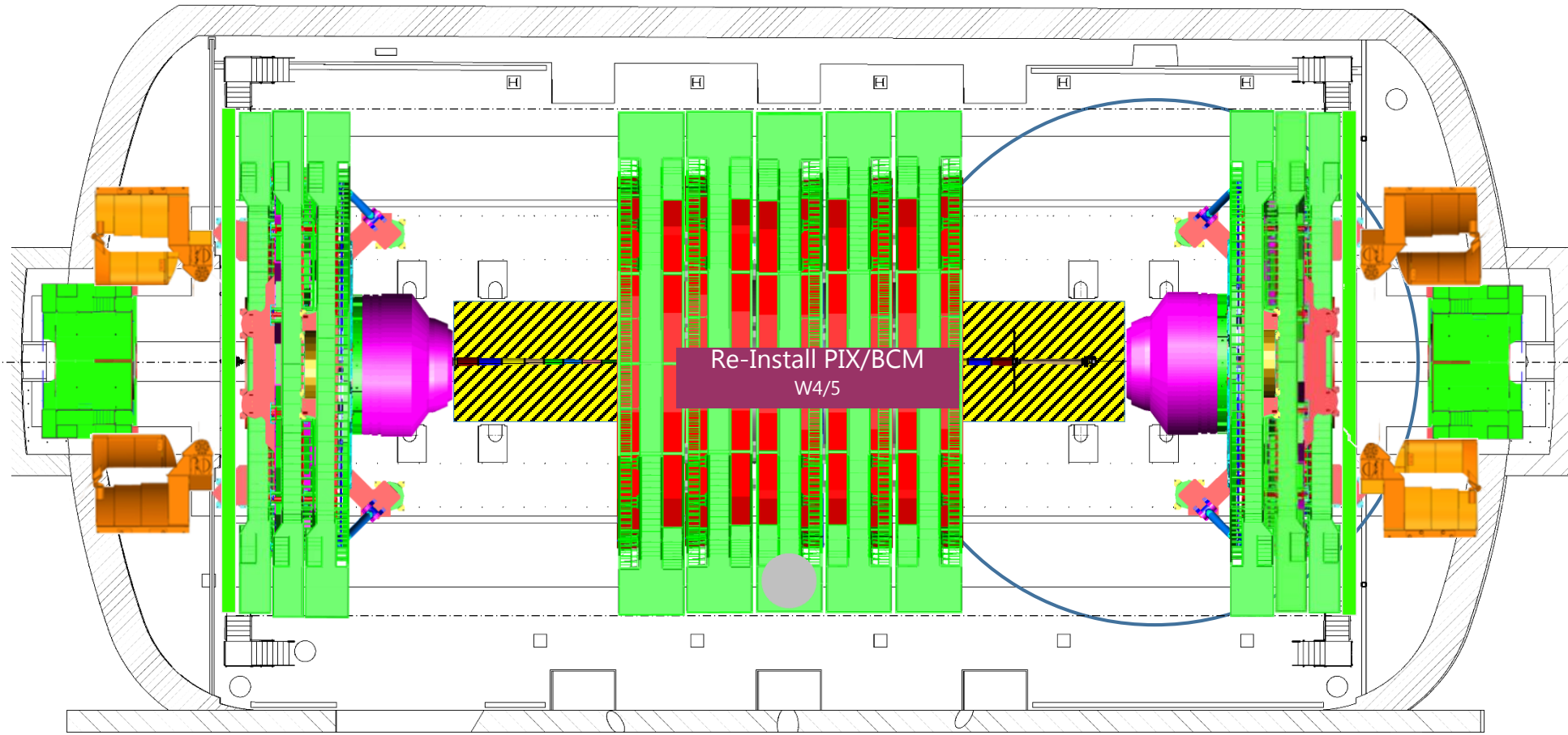
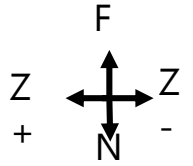

5m



Crane

Cryo.	EL power	Water cool.	Database				
IT	Magnet	C6F14	Gas				
SL. 0	GEM	ECAL	ZEC	DT+ RB	Survey	TE-VSC	GS Dept
CP. 0	TOTEM	CMX	CSC RE	TK PIX	HCAL	EN Dept	RP

PX56 Plug CLOSED
TX54 Plug CLOSED

2020
December - Week 50

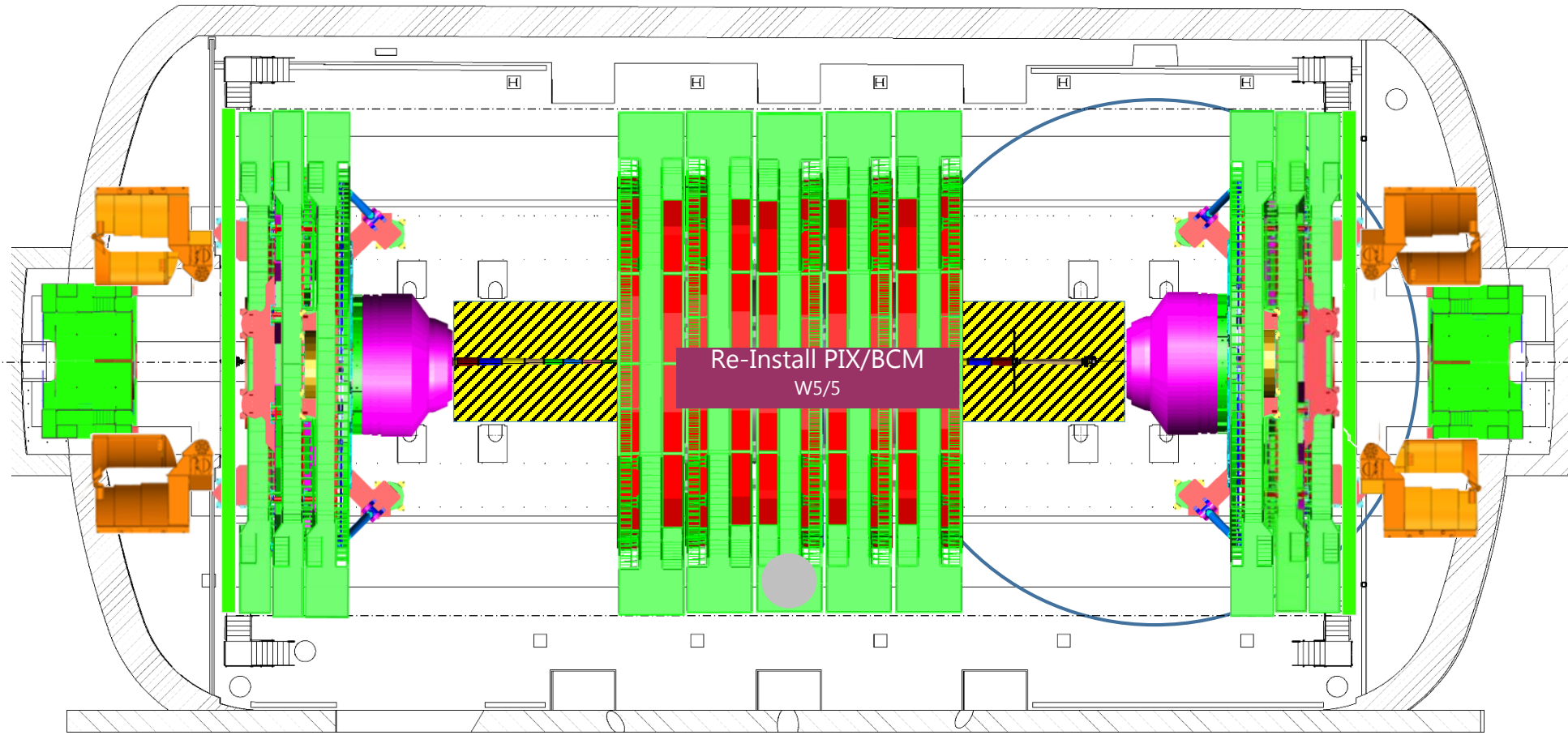
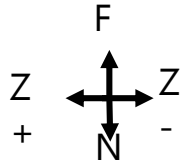

5m



Cryo.	█	EL power	█	Water cool.	█	Database	█
IT	█	Magnet	█	C6F14	█	Gas	█
SL. 0	GEM	ECAL	ZEC	DT+ RB	Survey	TE-VSC	GS Dept
CP. 0	TOTEM	CMX	CSC RE	TK PIX	HCAL	EN Dept	RP

PX56 Plug
CLOSED

TX54 Plug
CLOSED

2020

December - Week 51

Crane

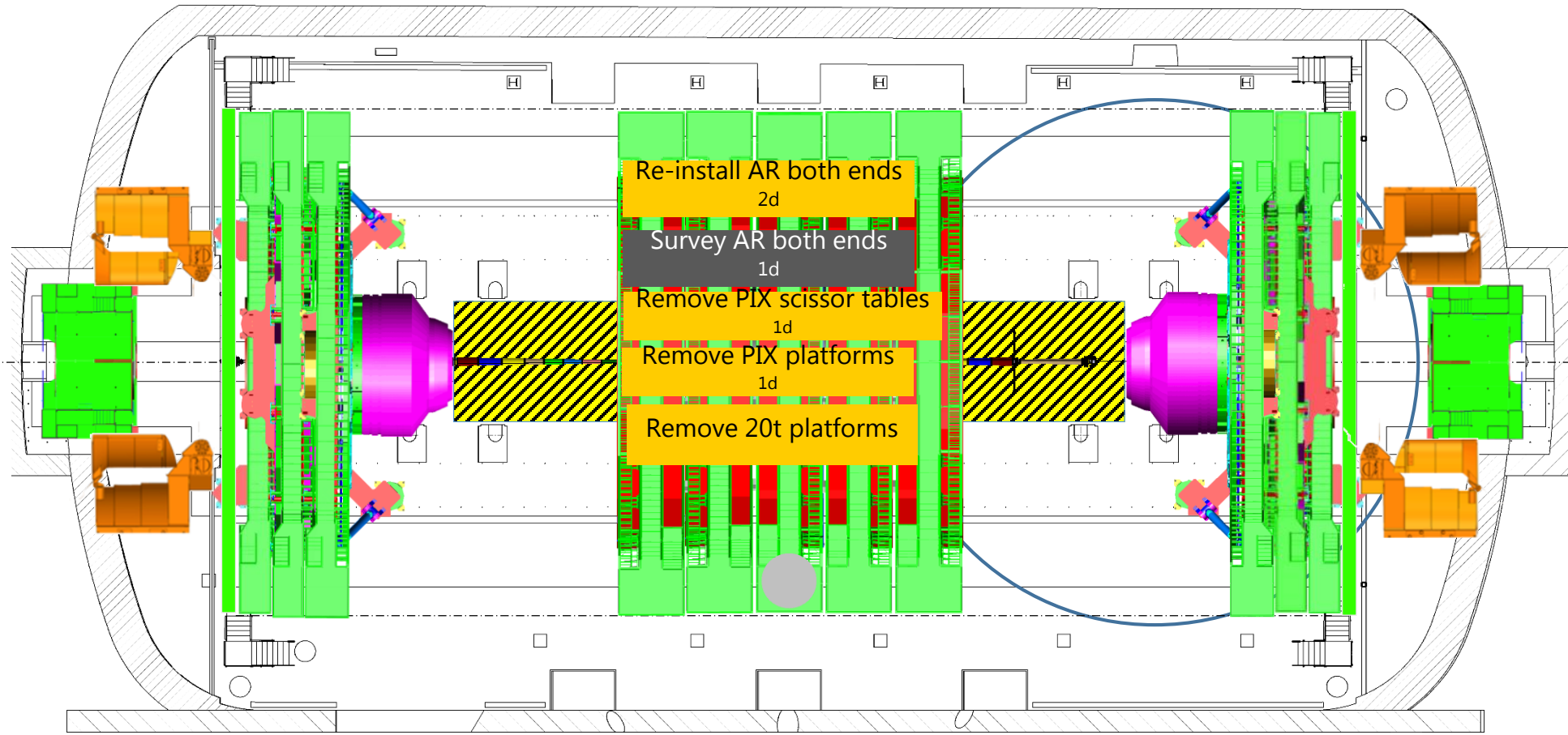
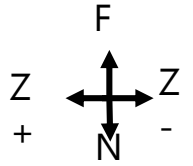

5m



Crane

Cryo.	<input type="checkbox"/>	EL power	<input type="checkbox"/>	Water cool.	<input type="checkbox"/>	Database	<input type="checkbox"/>	
IT	<input type="checkbox"/>	Magnet	<input type="checkbox"/>	C6F14	<input type="checkbox"/>	Gas	<input type="checkbox"/>	
SL.	0	GEM	ECAL	ZEC	DT+ RB	Survey	TE-VSC	GS Dept
CP.	0	TOTEM	CMX	CSC RE	TK PIX	HCAL	EN Dept	RP

PX56 Plug	CLOSED
TX54 Plug	CLOSED

2020

December - Week 52

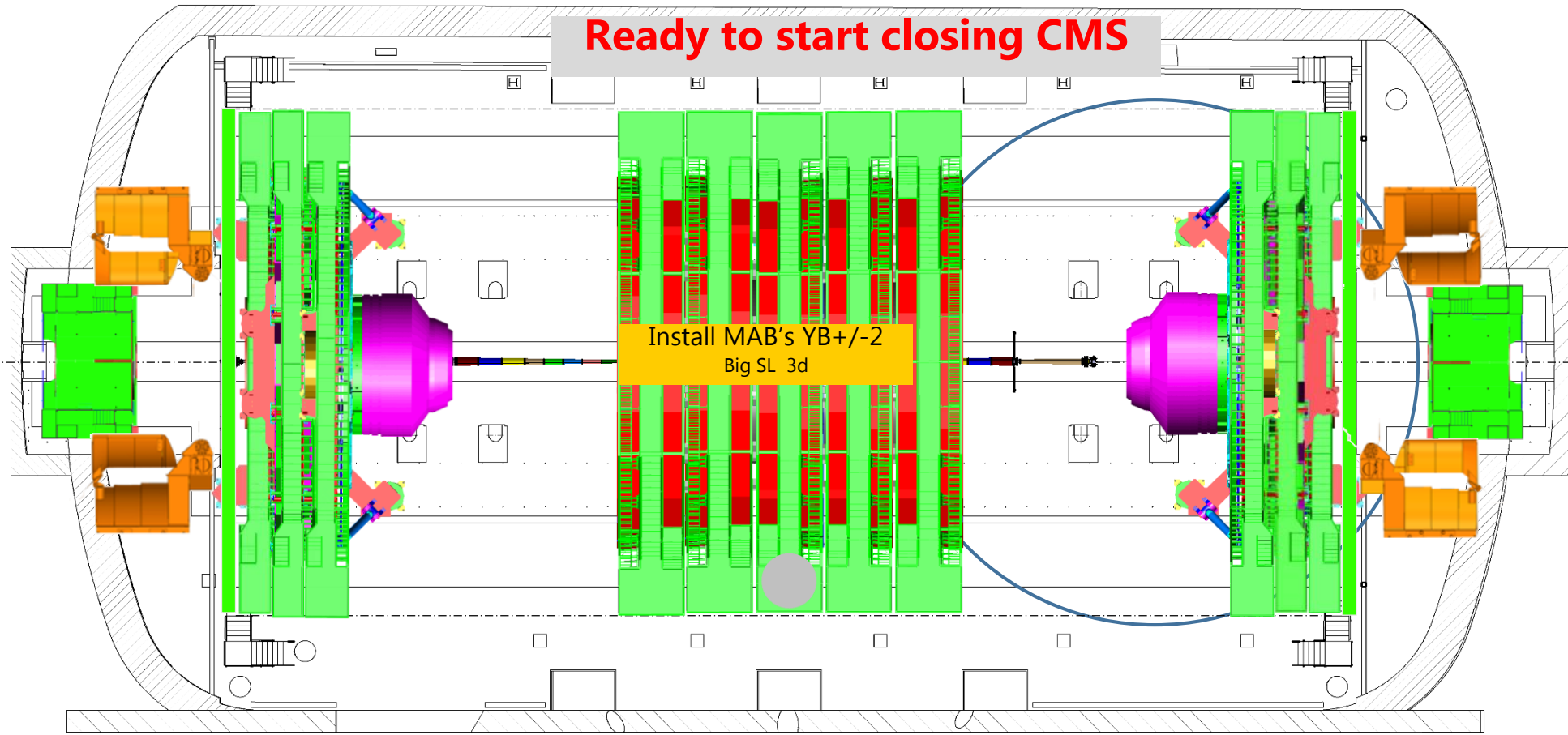
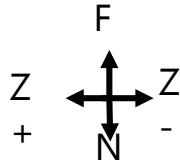

Ready to start closing CMS

Install MAB's YB+/-2
Big SL 3d

5m



Crane

Cryo.	█	EL power	█	Water cool.	█	Database	█
IT	█	Magnet	█	C6F14	█	Gas	█
SL. 0	GEM	ECAL	ZEC	DT+ RB	Survey	TE-VSC	GS Dept
CP. 0	TOTEM	CMX	CSC RE	TK PIX	HCAL	EN Dept	RP

PX56 Plug
CLOSED

2020

TX54 Plug
CLOSED

December - Week 53

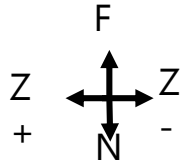

End of year lab closure

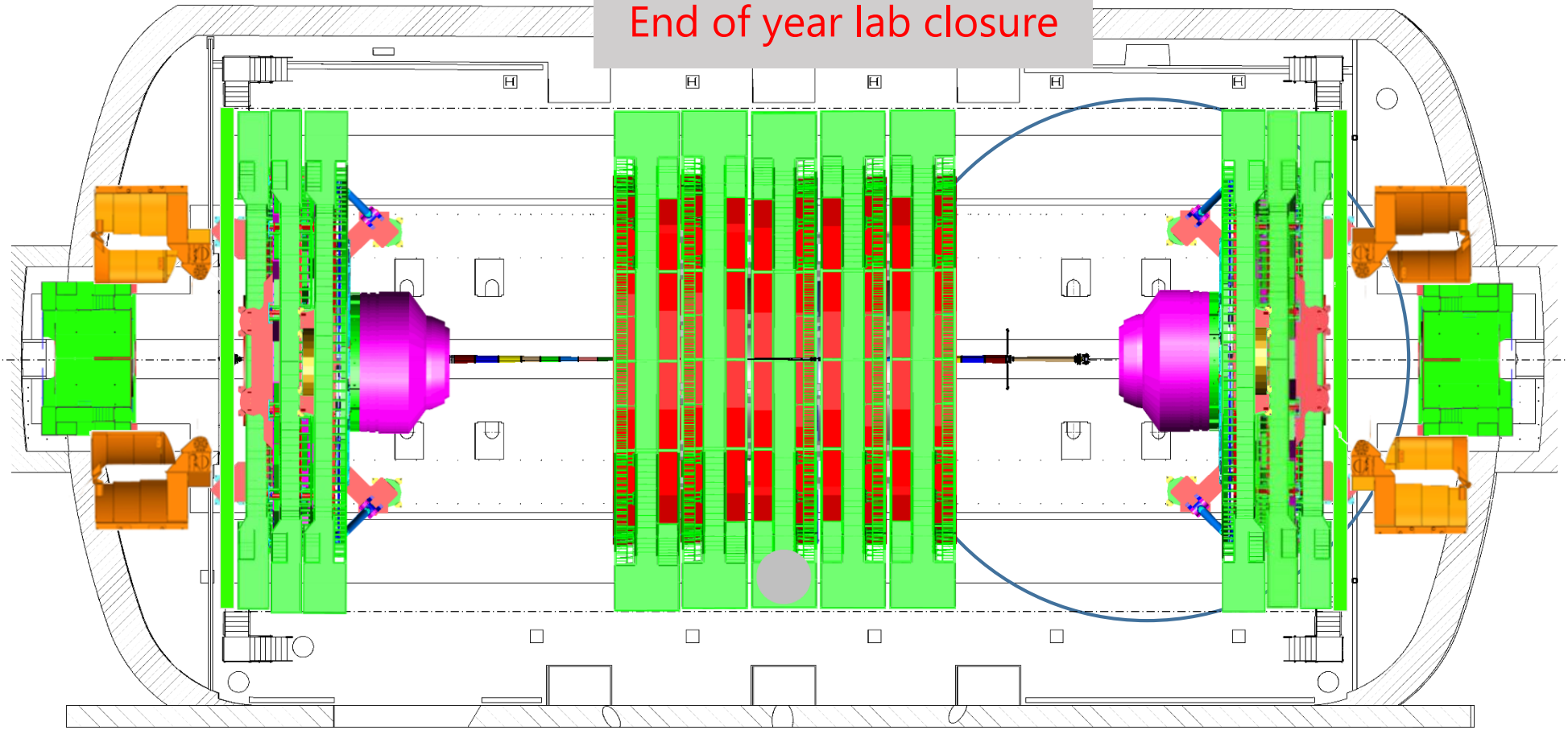

5m



Crane

Cryo.	█	EL power	█	Water cool.	█	Database	█
IT	█	Magnet	█	C6F14	█	Gas	█
SL. 0	GEM	ECAL	ZEC	DT+ RB	Survey	TE-VSC	GS Dept
CP. 0	TOTEM	CMX	CSC RE	TK PIX	HCAL	EN Dept	RP

PX56 Plug
CLOSED

2021

TX54 Plug
CLOSED

January - Week 1

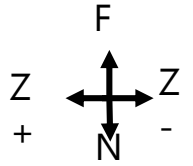

End of year lab closure

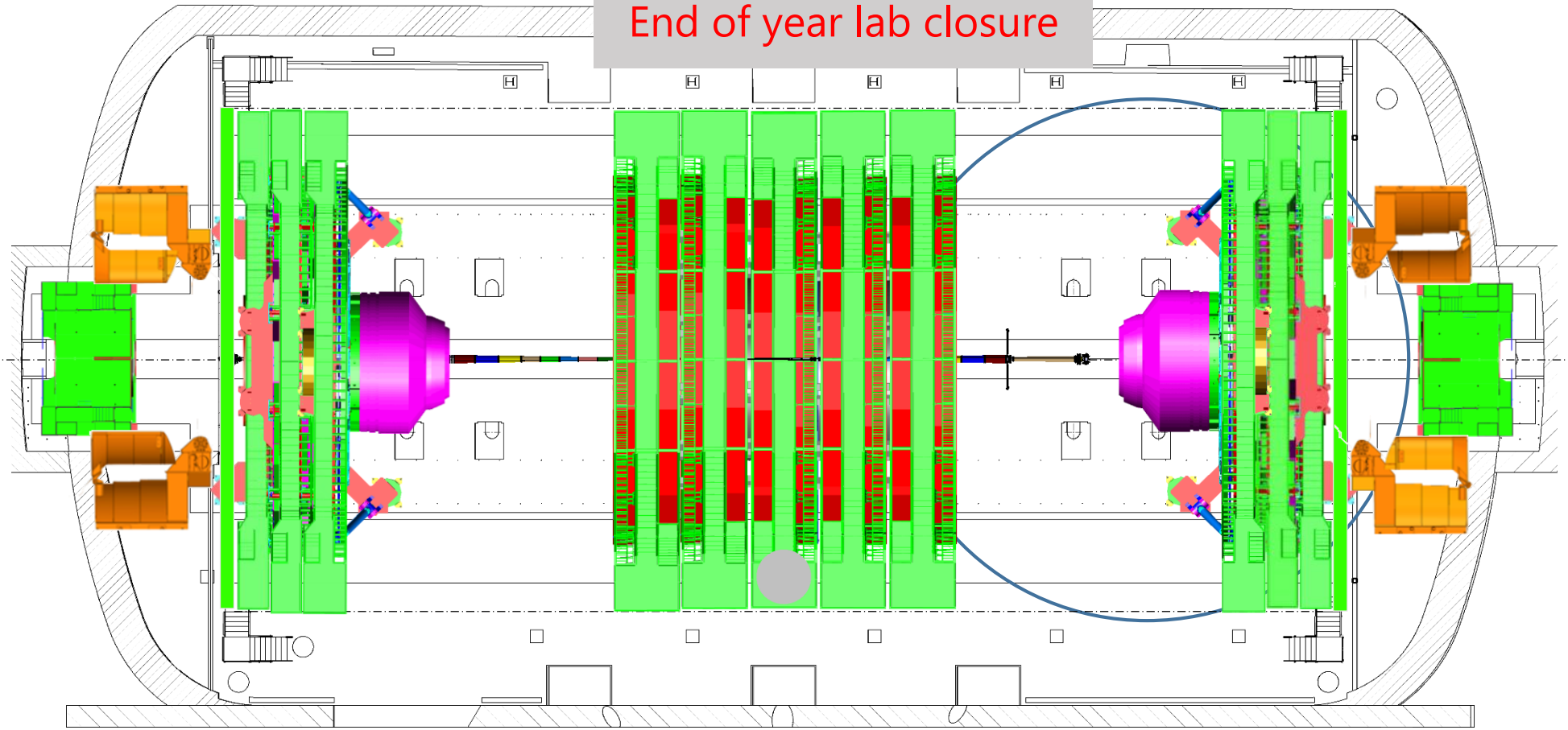

5m



Cryo.	■	EL power	■	Water cool.	■	Database	■
IT	■	Magnet	■	C6F14	■	Gas	■
SL. 0	GEM	ECAL	ZEC	DT+ RB	Survey	TE-VSC	GS Dept
CP. 0	TOTEM	CMX	CSC RE	TK PIX	HCAL	EN Dept	RP

PX56 Plug
CLOSED

TX54 Plug
CLOSED

2021

January - Week 2

Crane

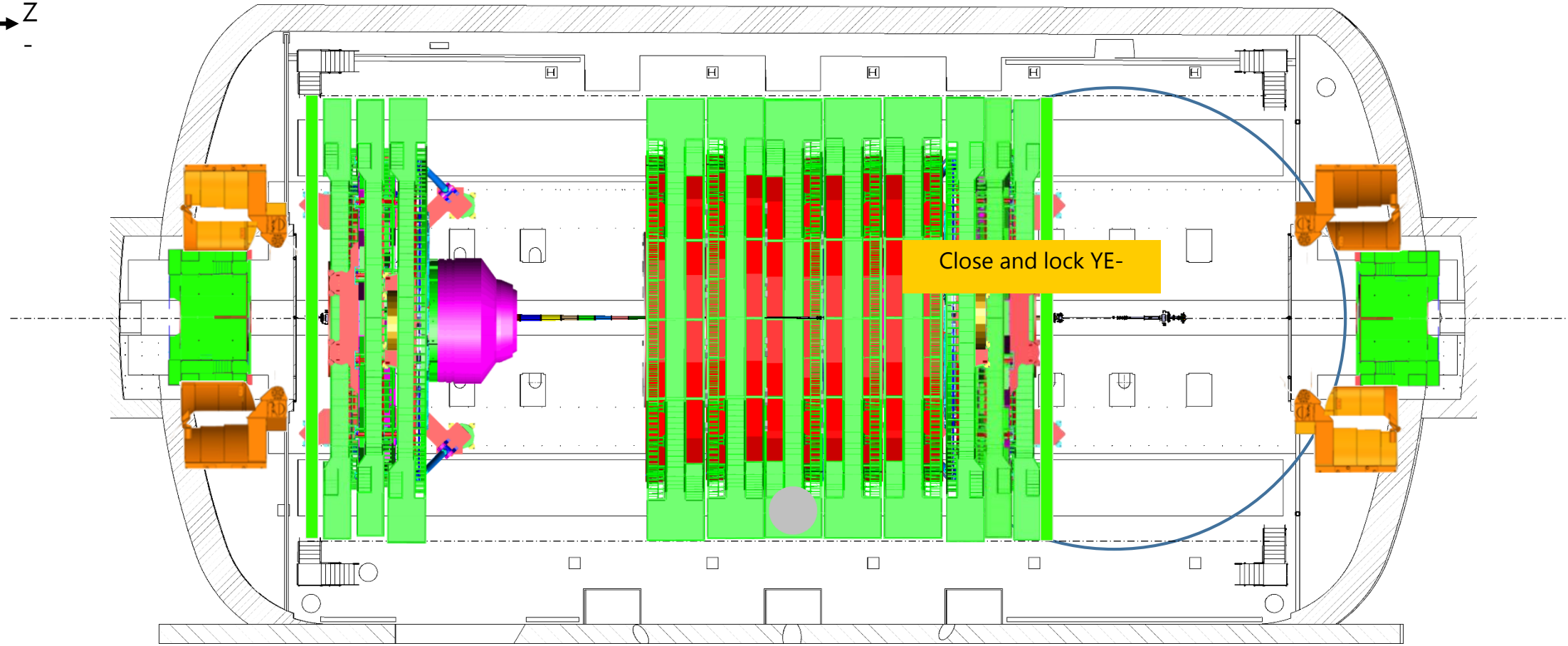
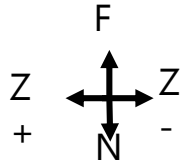

5m



Crane

Cryo.	█	EL power	█	Water cool.	█	Database	█
IT	█	Magnet	█	C6F14	█	Gas	█
SL. 0	GEM	ECAL	ZEC	DT+ RB	Survey	TE-VSC	GS Dept
CP. 0	TOTEM	CMX	CSC RE	TK PIX	HCAL	EN Dept	RP

PX56 Plug
CLOSED

2021

TX54 Plug
CLOSED

January - Week 3

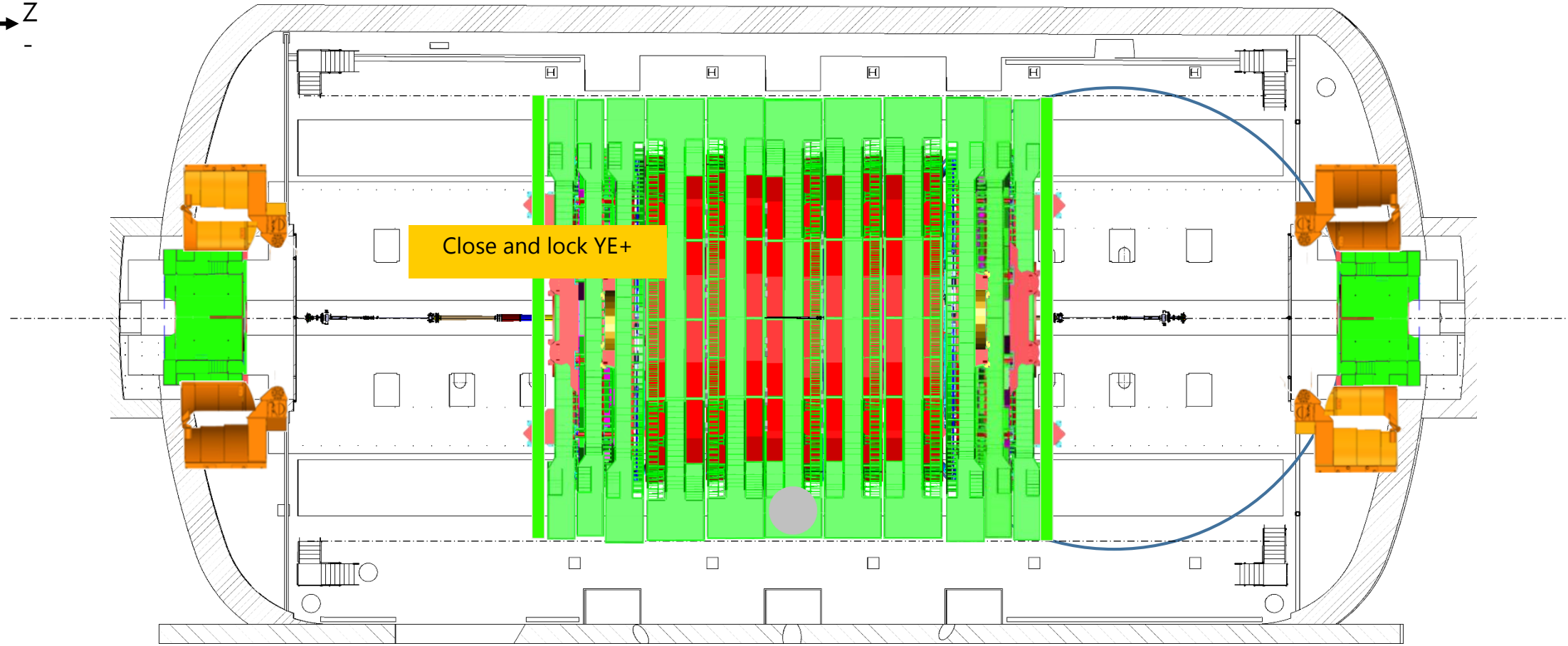
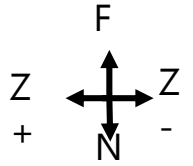

5m



Cryo.	■	EL power	■	Water cool.	■	Database	■
IT	■	Magnet	■	C6F14	■	Gas	■
SL. 0	GEM	ECAL	ZEC	DT+ RB	Survey	TE-VSC	GS Dept
CP. 0	TOTEM	CMX	CSC RE	TK PIX	HCAL	EN Dept	RP

PX56 Plug CLOSED	2021
TX54 Plug CLOSED	January - Week 4

Crane

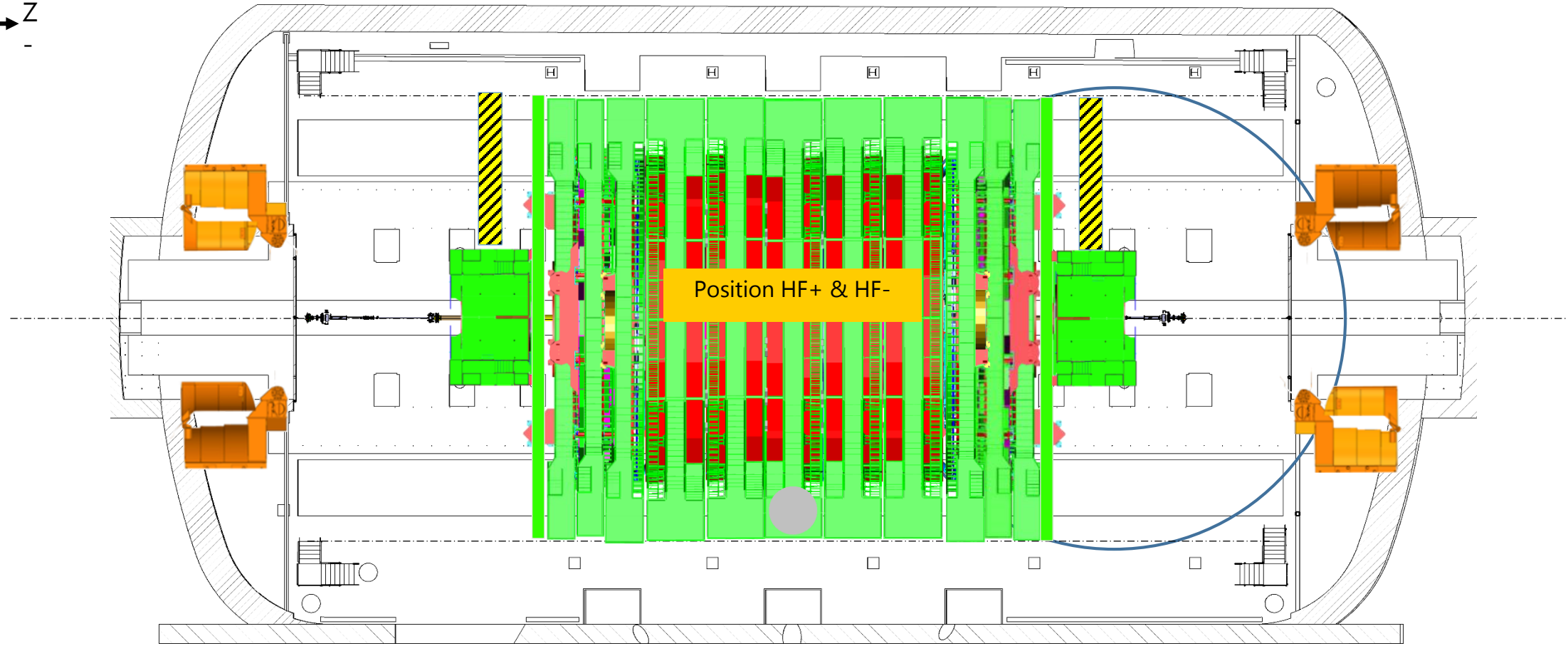
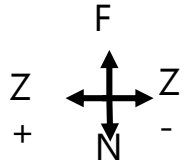

5m



Crane

Cryo.	■	EL power	■	Water cool.	■	Database	■
IT	■	Magnet	■	C6F14	■	Gas	■
SL. 0	GEM	ECAL	ZEC	DT+ RB	Survey	TE-VSC	GS Dept
CP. 0	TOTEM	CMX	CSC RE	TK PIX	HCAL	EN Dept	RP

PX56 Plug
CLOSED

2021

TX54 Plug
CLOSED

February - Week 5

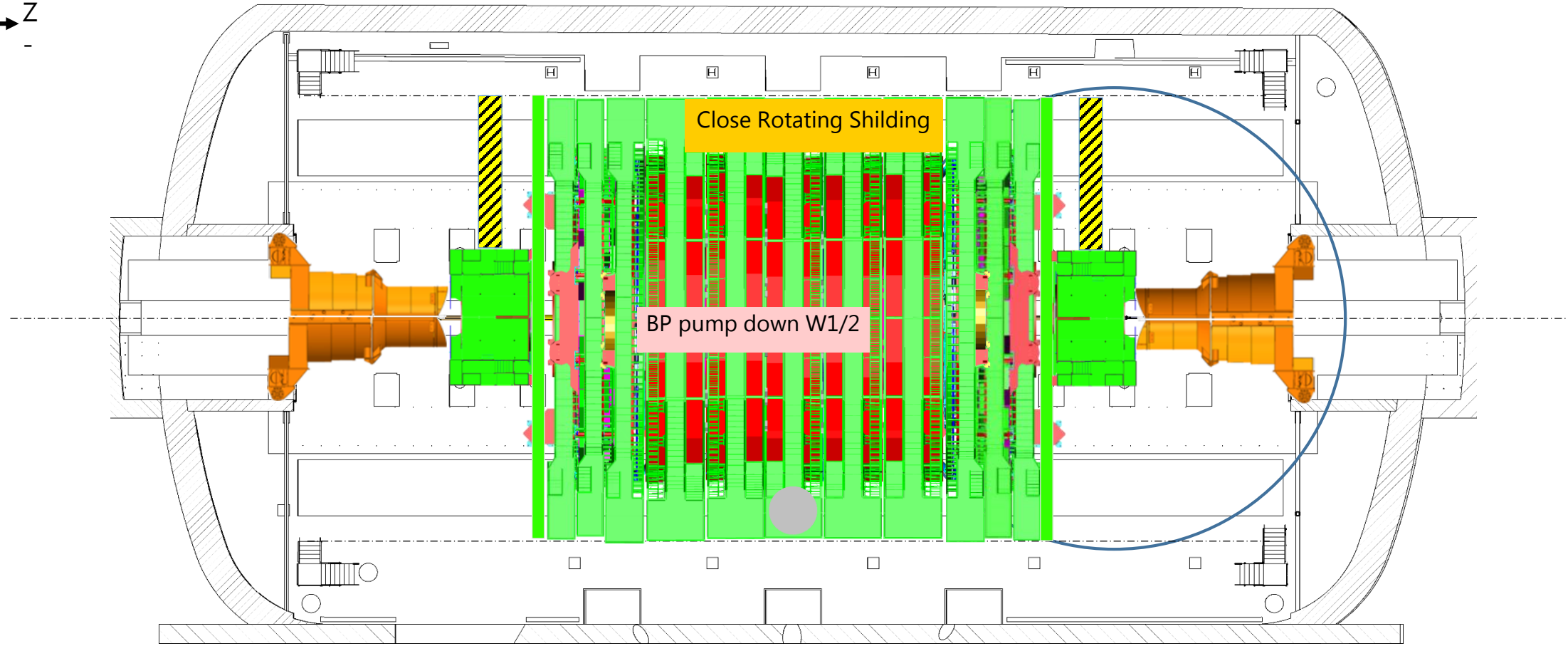
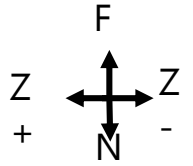

5m



Crane

Cryo.	■	EL power	■	Water cool.	■	Database	■
IT	■	Magnet	■	C6F14	■	Gas	■
SL. 0	GEM	ECAL	ZEC	DT+ RB	Survey	TE-VSC	GS Dept
CP. 0	TOTEM	CMX	CSC RE	TK PIX	HCAL	EN Dept	RP

PX56 Plug
CLOSED

TX54 Plug
CLOSED

2021

February - Week 6

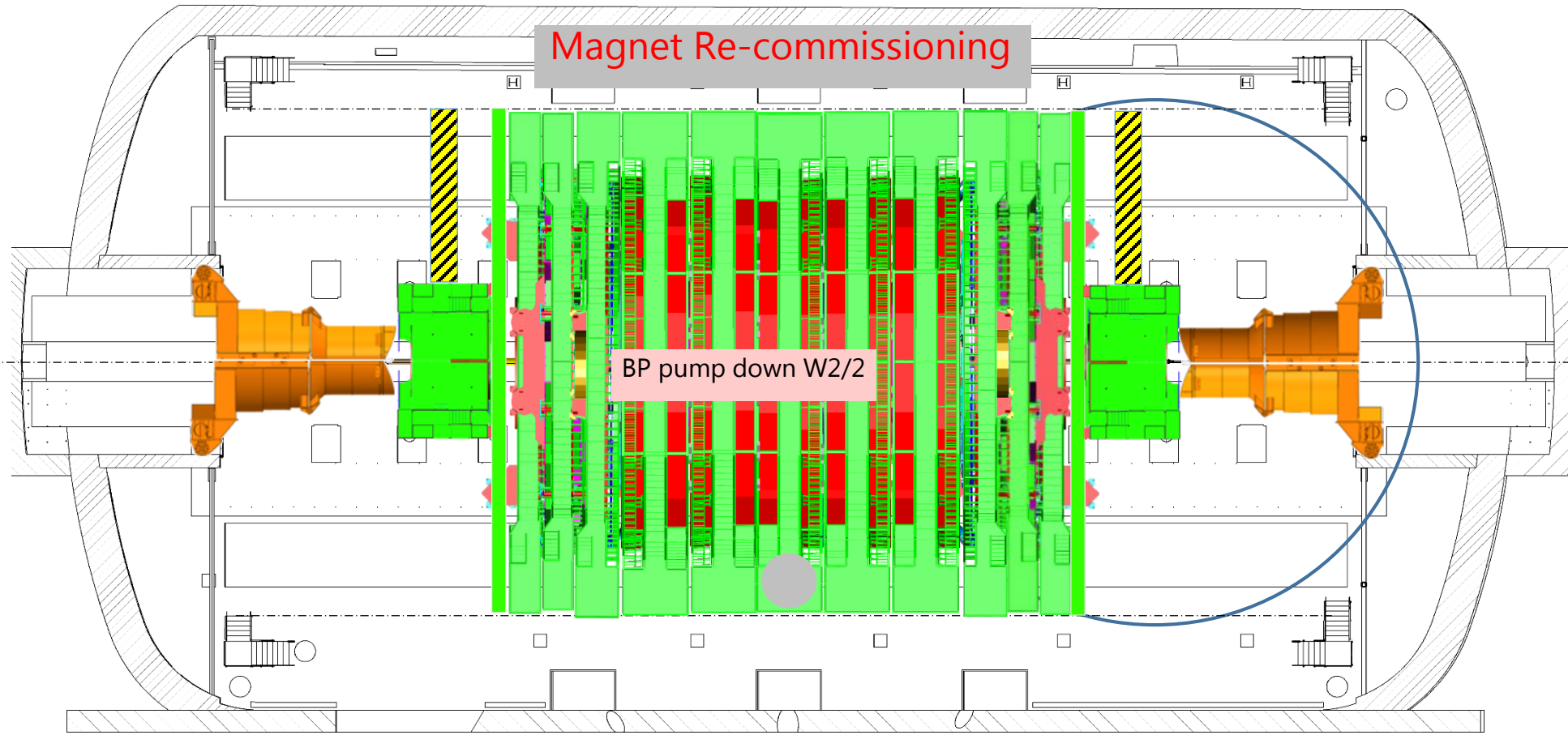
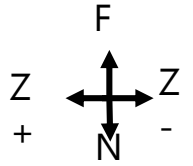

5m



Crane

Cryo.	█	EL power	█	Water cool.	█	Database	█
IT	█	Magnet	█	C6F14	█	Gas	█
SL. 0	GEM	ECAL	ZEC	DT+ RB	Survey	TE-VSC	GS Dept
CP. 0	TOTEM	CMX	CSC RE	TK PIX	HCAL	EN Dept	RP

PX56 Plug CLOSED
TX54 Plug CLOSED

2021
February - Week 7

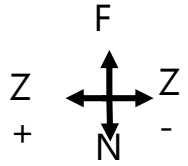

Ready for re-commissioning with Beam

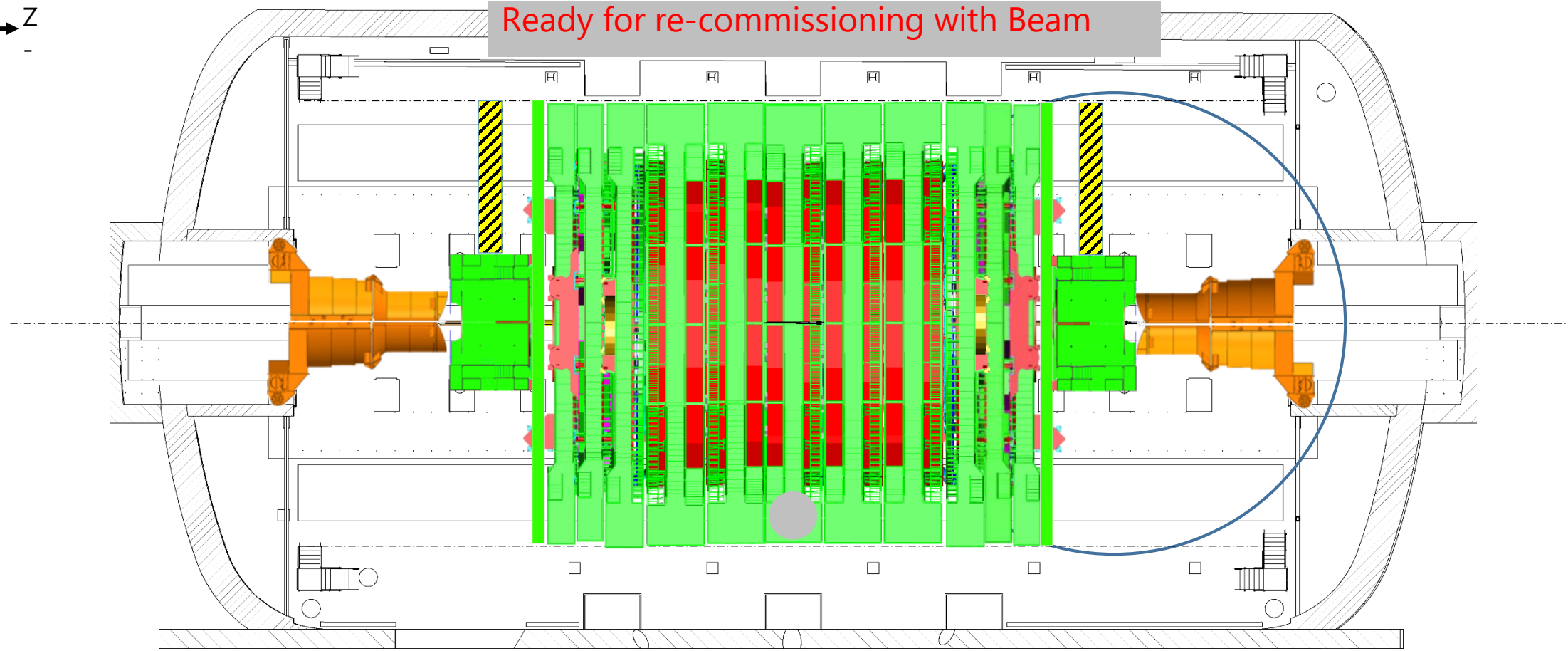

5m



Crane

Cryo.	■	EL power	■	Water cool.	■	Database	■
IT	■	Magnet	■	C6F14	■	Gas	■
SL. 0	GEM	ECAL	ZEC	DT+ RB	Survey	TE-VSC	GS Dept
CP. 0	TOTEM	CMX	CSC RE	TK PIX	HCAL	EN Dept	RP

PX56 Plug
CLOSED

TX54 Plug
CLOSED

2021

February - Week 08

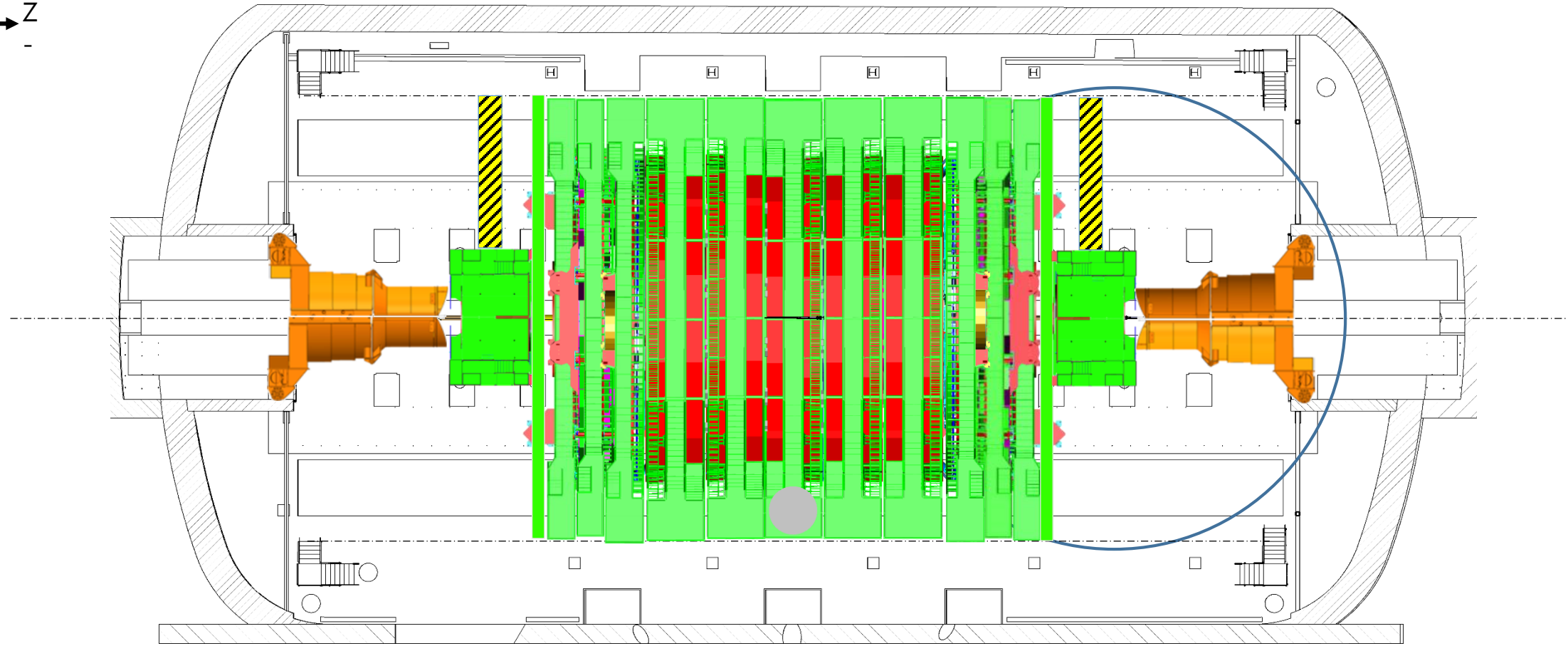
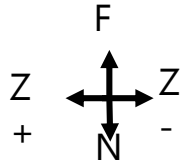

5m



Crane

Cryo.	■	EL power	■	Water cool.	■	Database	■
IT	■	Magnet	■	C6F14	■	Gas	■
SL. 0	GEM	ECAL	ZEC	DT+ RB	Survey	TE-VSC	GS Dept
CP. 0	TOTEM	CMX	CSC RE	TK PIX	HCAL	EN Dept	RP

PX56 Plug CLOSED	2021
TX54 Plug CLOSED	March - Week 09

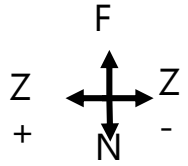

Last week of LS2

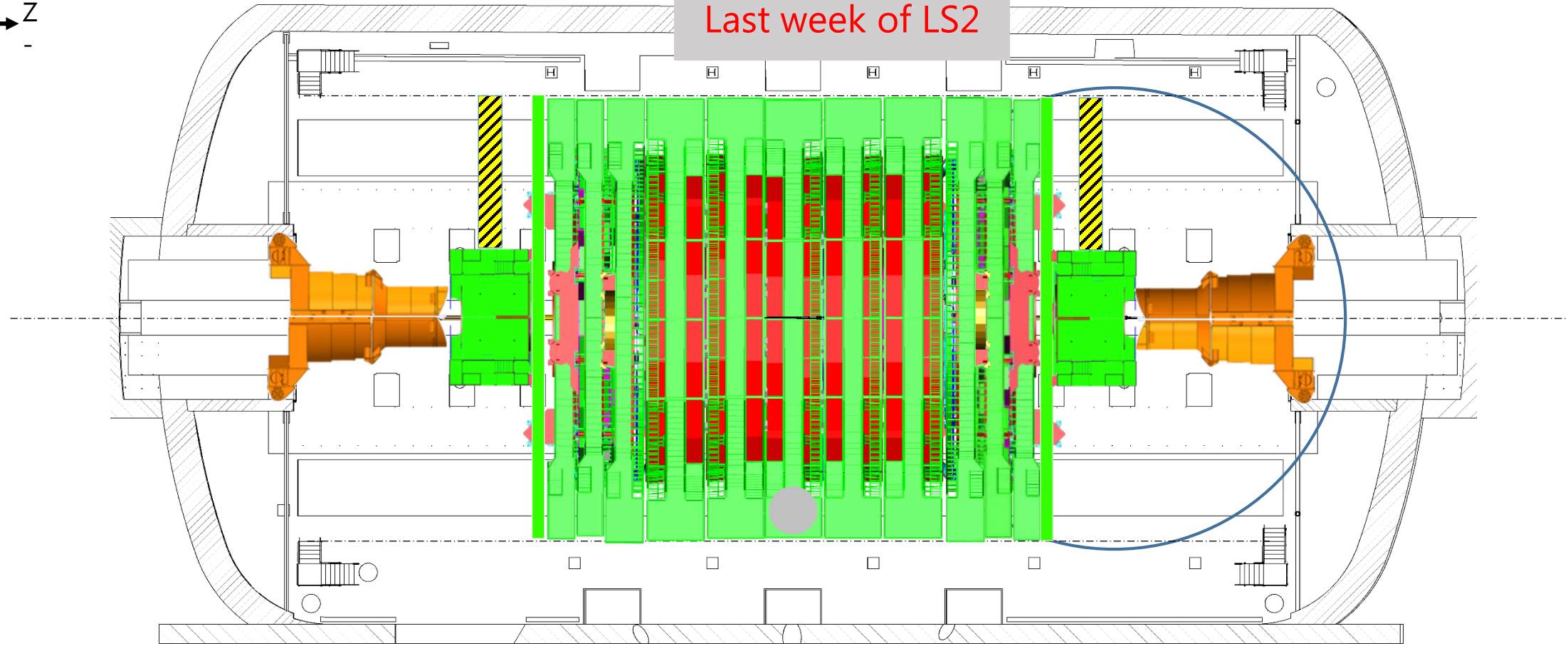

5m