



# Long Shutdown 2 2018-2021 Week by Week Schedule

Many thanks for your input

# Working days 2018-19

**December 2018**  
1 days included

Mon	Tue	Wed	Thu	Fri	Sat	Sun
					1	2
3	4	5	6	7	8	9
10	11	12	13	14	15	16
17	18	19	20	21	22	23
24	25	26	27	28	29	30
31						

**January 2019**  
22 days included

Mon	Tue	Wed	Thu	Fri	Sat	Sun
	1	2	3	4	5	6
7	8	9	10	11	12	13
14	15	16	17	18	19	20
21	22	23	24	25	26	27
28	29	30	31			

**February 2019**  
20 days included

Mon	Tue	Wed	Thu	Fri	Sat	Sun
				1	2	3
4	5	6	7	8	9	10
11	12	13	14	15	16	17
18	19	20	21	22	23	24
25	26	27	28			

**March 2019**  
21 days included

Mon	Tue	Wed	Thu	Fri	Sat	Sun
				1	2	3
4	5	6	7	8	9	10
11	12	13	14	15	16	17
18	19	20	21	22	23	24
25	26	27	28	29	30	31

**April 2019**  
20 days included

Mon	Tue	Wed	Thu	Fri	Sat	Sun
1	2	3	4	5	6	7
8	9	10	11	12	13	14
15	16	17	18	19	20	21
22	23	24	25	26	27	28
29	30					

**May 2019**  
22 days included

Mon	Tue	Wed	Thu	Fri	Sat	Sun
		1	2	3	4	5
6	7	8	9	10	11	12
13	14	15	16	17	18	19
20	21	22	23	24	25	26
27	28	29	30	31		

**June 2019**  
19 days included

Mon	Tue	Wed	Thu	Fri	Sat	Sun
					1	2
3	4	5	6	7	8	9
10	11	12	13	14	15	16
17	18	19	20	21	22	23
24	25	26	27	28	29	30

**July 2019**  
23 days included

Mon	Tue	Wed	Thu	Fri	Sat	Sun
1	2	3	4	5	6	7
8	9	10	11	12	13	14
15	16	17	18	19	20	21
22	23	24	25	26	27	28
29	30	31				

**August 2019**  
21 days included

Mon	Tue	Wed	Thu	Fri	Sat	Sun
			1	2	3	4
5	6	7	8	9	10	11
12	13	14	15	16	17	18
19	20	21	22	23	24	25
26	27	28	29	30	31	

**September 2019**  
20 days included

Mon	Tue	Wed	Thu	Fri	Sat	Sun
						1
2	3	4	5	6	7	8
9	10	11	12	13	14	15
16	17	18	19	20	21	22
23	24	25	26	27	28	29
30						

**October 2019**  
23 days included

Mon	Tue	Wed	Thu	Fri	Sat	Sun
	1	2	3	4	5	6
7	8	9	10	11	12	13
14	15	16	17	18	19	20
21	22	23	24	25	26	27
28	29	30	31			

**November 2019**  
21 days included

Mon	Tue	Wed	Thu	Fri	Sat	Sun
				1	2	3
4	5	6	7	8	9	10
11	12	13	14	15	16	17
18	19	20	21	22	23	24
25	26	27	28	29	30	

**December 2019**  
1 days included

Mon	Tue	Wed	Thu	Fri	Sat	Sun
						1
2	3	4	5	6	7	8
9	10	11	12	13	14	15
16	17	18	19	20	21	22
23	24	25	26	27	28	29
30	31					

11/06/18

cms-tc-planning@cern.ch

# Working Days 2020

**January 2020**  
2 days included

Mon	Tue	Wed	Thu	Fri	Sat	Sun
		1	2	3	4	5
6	7	8	9	10	11	12
13	14	15	16	17	18	19
20	21	22	23	24	25	26
27	28	29	30	31		

**February 2020**  
20 days included

Mon	Tue	Wed	Thu	Fri	Sat	Sun
					1	2
3	4	5	6	7	8	9
10	11	12	13	14	15	16
17	18	19	20	21	22	23
24	25	26	27	28	29	

**March 2020**  
22 days included

Mon	Tue	Wed	Thu	Fri	Sat	Sun
						1
2	3	4	5	6	7	8
9	10	11	12	13	14	15
16	17	18	19	20	21	22
23	24	25	26	27	28	29
30	31					

**April 2020**  
20 days included

Mon	Tue	Wed	Thu	Fri	Sat	Sun
		1	2	3	4	5
6	7	8	9	10	11	12
13	14	15	16	17	18	19
20	21	22	23	24	25	26
27	28	29	30			

**May 2020**  
20 days included

Mon	Tue	Wed	Thu	Fri	Sat	Sun
				1	2	3
4	5	6	7	8	9	10
11	12	13	14	15	16	17
18	19	20	21	22	23	24
25	26	27	28	29	30	31

**June 2020**  
21 days included

Mon	Tue	Wed	Thu	Fri	Sat	Sun
1	2	3	4	5	6	7
8	9	10	11	12	13	14
15	16	17	18	19	20	21
22	23	24	25	26	27	28
29	30					

**July 2020**  
23 days included

Mon	Tue	Wed	Thu	Fri	Sat	Sun
		1	2	3	4	5
6	7	8	9	10	11	12
13	14	15	16	17	18	19
20	21	22	23	24	25	26
27	28	29	30	31		

**August 2020**  
21 days included

Mon	Tue	Wed	Thu	Fri	Sat	Sun
					1	2
3	4	5	6	7	8	9
10	11	12	13	14	15	16
17	18	19	20	21	22	23
24	25	26	27	28	29	30
31						

**September 2020**  
21 days included

Mon	Tue	Wed	Thu	Fri	Sat	Sun
	1	2	3	4	5	6
7	8	9	10	11	12	13
14	15	16	17	18	19	20
21	22	23	24	25	26	27
28	29	30				

**October 2020**  
22 days included

Mon	Tue	Wed	Thu	Fri	Sat	Sun
			1	2	3	4
5	6	7	8	9	10	11
12	13	14	15	16	17	18
19	20	21	22	23	24	25
26	27	28	29	30	31	

**November 2020**  
21 days included

Mon	Tue	Wed	Thu	Fri	Sat	Sun
						1
2	3	4	5	6	7	8
9	10	11	12	13	14	15
16	17	18	19	20	21	22
23	24	25	26	27	28	29
30						

**December 2020**  
1 days included

Mon	Tue	Wed	Thu	Fri	Sat	Sun
	1	2	3	4	5	6
7	8	9	10	11	12	13
14	15	16	17	18	19	20
21	22	23	24	25	26	27
28	29	30	31			

# Working Days 2021

January 2021						
20 days included						
Mon	Tue	Wed	Thu	Fri	Sat	Sun
				1	2	3
4	5	6	7	8	9	10
11	12	13	14	15	16	17
18	19	20	21	22	23	24
25	26	27	28	29	30	31

February 2021						
20 days included						
Mon	Tue	Wed	Thu	Fri	Sat	Sun
1	2	3	4	5	6	7
8	9	10	11	12	13	14
15	16	17	18	19	20	21
22	23	24	25	26	27	28

# Design Method

---

## → Assumptions

- 5 working days/week = 561 days
- Bank holidays / Lab closure included
- Shift work possible when required
- Current levels of expertise maintained
- Using proven existing tooling

# Objectives not included in this draft

---

- CMS Safety activities
- ECAL activities
- Rotating shielding...
- UXC55 X1 floor survey
- HF grease pad maintenance
- HVAC software upgrade

# Key objectives

---

## Infrastructure:

- Modify SCX5 Ctrl room by beginning of LS2 – CMS/SMB
- Build SXA5 – CMS/SMB
- Add UPS for the DAQ computer farm – EN-EL
- Move SCX5 UPS out of ctrl room to dedicated UPS building – EN-EL ???
- Add 1.5 MW cooling capacity to the chilled water system –EN-CV
  - Check with Paola
- Refurbish SUX5 control infrastructure for chilled/mixed water production – EN-CV
- Refurbish USC55 control infrastructure for all water distribution system – EN-CV
- Consolidate instrument air infrastructure in SH5 – EN-CV
- Refurbish underground ventilation control system– EN-CV

# Key objectives

---

## Work on End Caps:

- Install new beam pipe
- Install GE1/1 (including pipes + cables – remove “slice test” detector installed in 2016)
- Refurbish ME2/1, ME3/1, ME4/1 – trigger latency boards
- Repair DT minicrates (4w per Barrel gap + 2w at EC-B interface)



# Key objectives

---

## Work on Barrels:

- Fix RPC leaks in barrel region (tackle worse chambers first)
- MB4 Shielding
- HB - Carry out phase1 upgrade of Front-End electronics, i.e. replacement of HPD->SiPMs



Crane

Cryo.	■	EL power	■	Water cool.	■	Database	■
IT	■	Magnet	■	C6F14	■	Gas	■
SL. 0	GEM	ECAL	ZEC	DT+ RB	Survey	TE-VSC	GS Dept
CP. 0	TOTEM	CMX	CSC RE	TK PIX	HCAL	EN Dept	<b>RP</b>

PX56 Plug CLOSED
TX54 Plug CLOSED

2018
December - Week 49

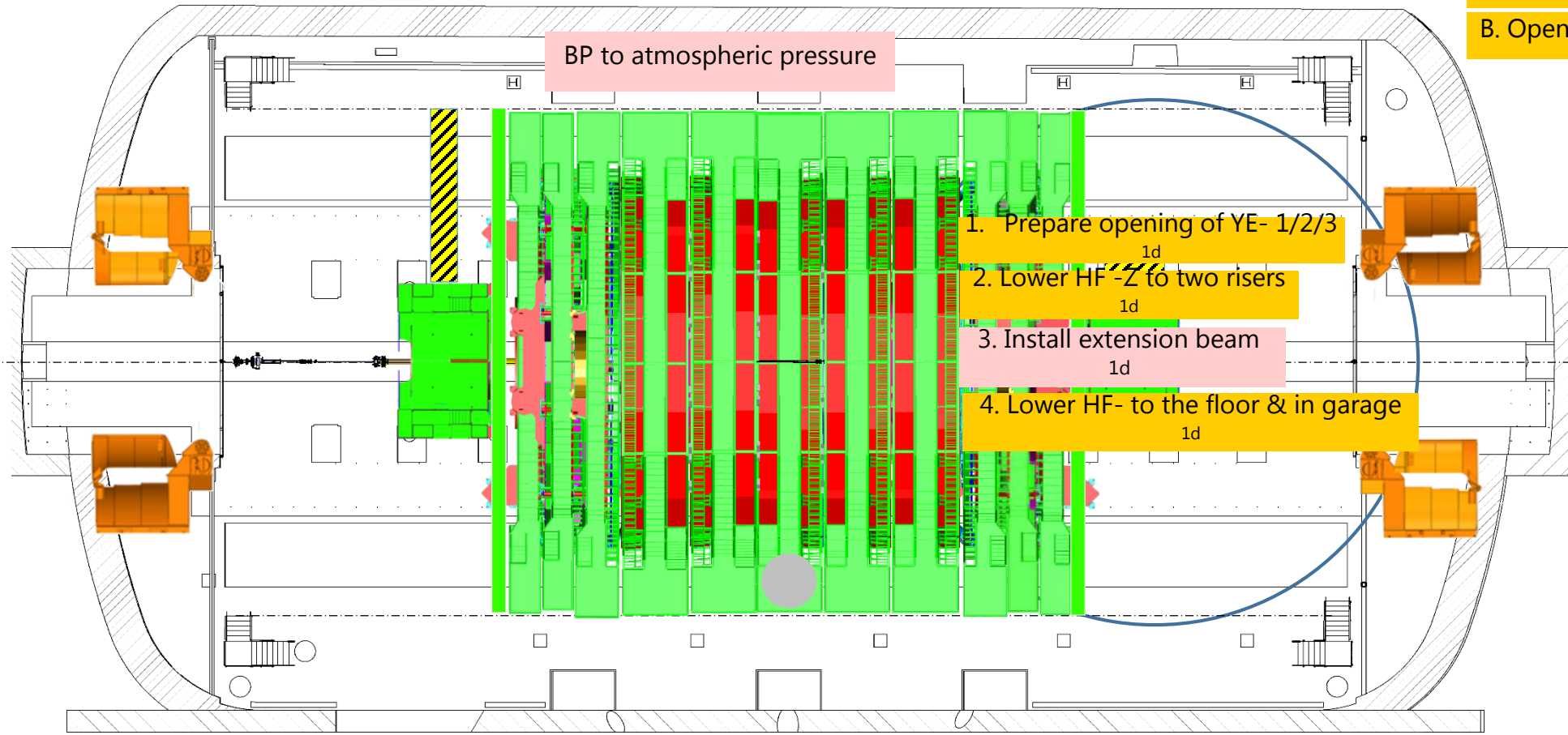
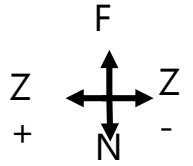

- A. Open PX56 Plug
- B. Open TX54 Plug

1. Prepare opening of YE- 1/2/3  
1d
2. Lower HF-Z to two risers  
1d
3. Install extension beam  
1d
4. Lower HF- to the floor & in garage  
1d

5m



Crane

Cryo.	■	EL power	■	Water cool.	■	Database	■
IT	■	Magnet	■	C6F14	■	Gas	■
SL. 0	GEM	ECAL	ZEC	DT+ RB	Survey	TE-VSC	GS Dept
CP. 0	TOTEM	CMX	CSC RE	TK PIX	HCAL	EN Dept	<b>RP</b>

PX56 Plug CLOSED
TX54 Plug CLOSED

2018
December - Week 50

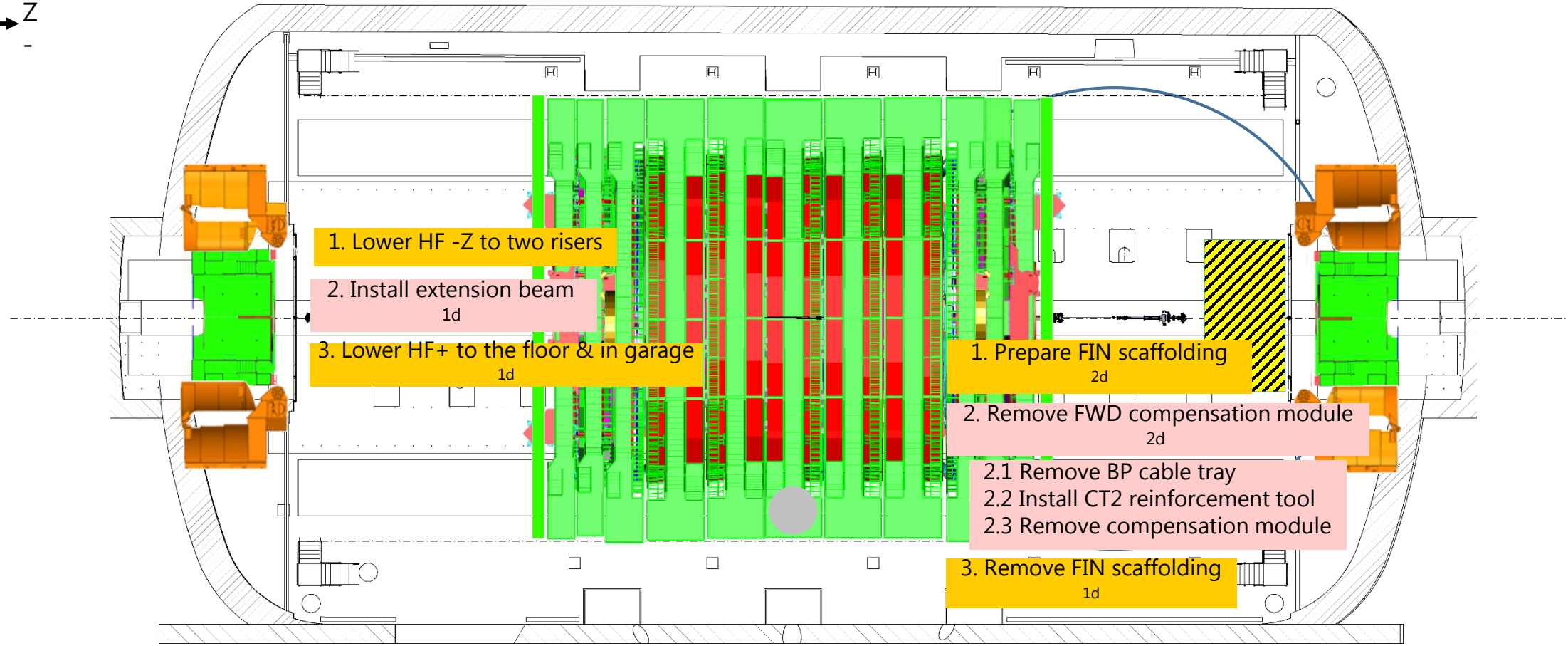
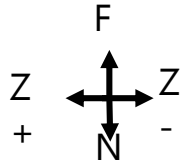

1. Lower HF -Z to two risers

2. Install extension beam  
1d

3. Lower HF+ to the floor & in garage  
1d

1. Prepare FIN scaffolding  
2d

2. Remove FWD compensation module  
2d

2.1 Remove BP cable tray  
2.2 Install CT2 reinforcement tool  
2.3 Remove compensation module

3. Remove FIN scaffolding  
1d

5m



Crane

Cryo.	■	EL power	■	Water cool.	■	Database	■								
IT	■	Magnet	■	C6F14	■	Gas	■								
SL.	0	GEM	■	ECAL	■	ZEC	■	DT+ RB	■	Survey	■	TE-VSC	■	GS Dept	■
CP.	0	TOTEM	■	CMX	■	CSC RE	■	TK PIX	■	HCAL	■	EN Dept	■	<b>RP</b>	■

PX56 Plug  
CLOSED

2018

TX54 Plug  
CLOSED

December - Week 51

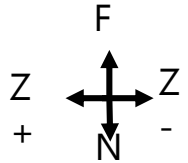

A. Open PX56 Plug

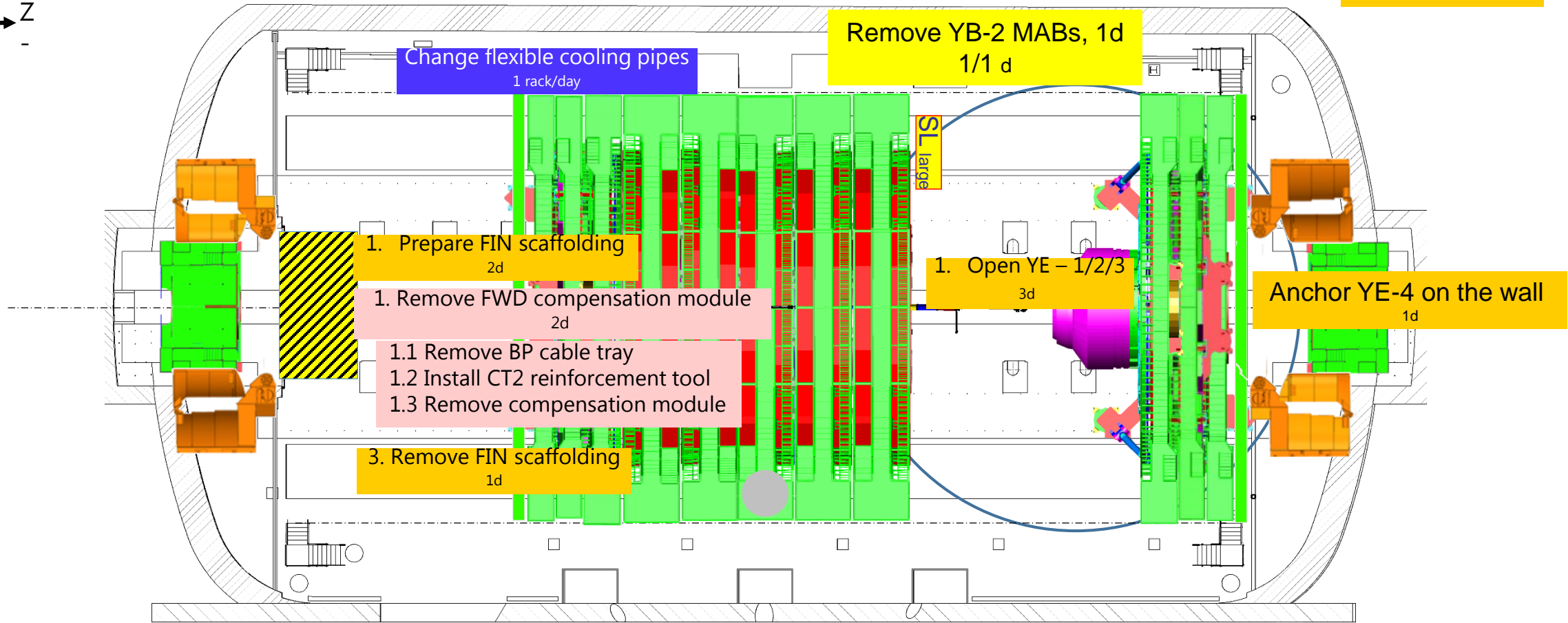

5m



Crane

Cryo.	■	EL power	■	Water cool.	■	Database	■
IT	■	Magnet	■	C6F14	■	Gas	■
SL. 0	GEM	ECAL	ZEC	DT+ RB	Survey	TE-VSC	GS Dept
CP. 0	TOTEM	CMX	CSC RE	TK PIX	HCAL	EN Dept	<b>RP</b>

PX56 Plug  
CLOSED

TX54 Plug  
CLOSED

2018

December - Week 52

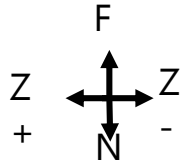

End of Year Lab Closure

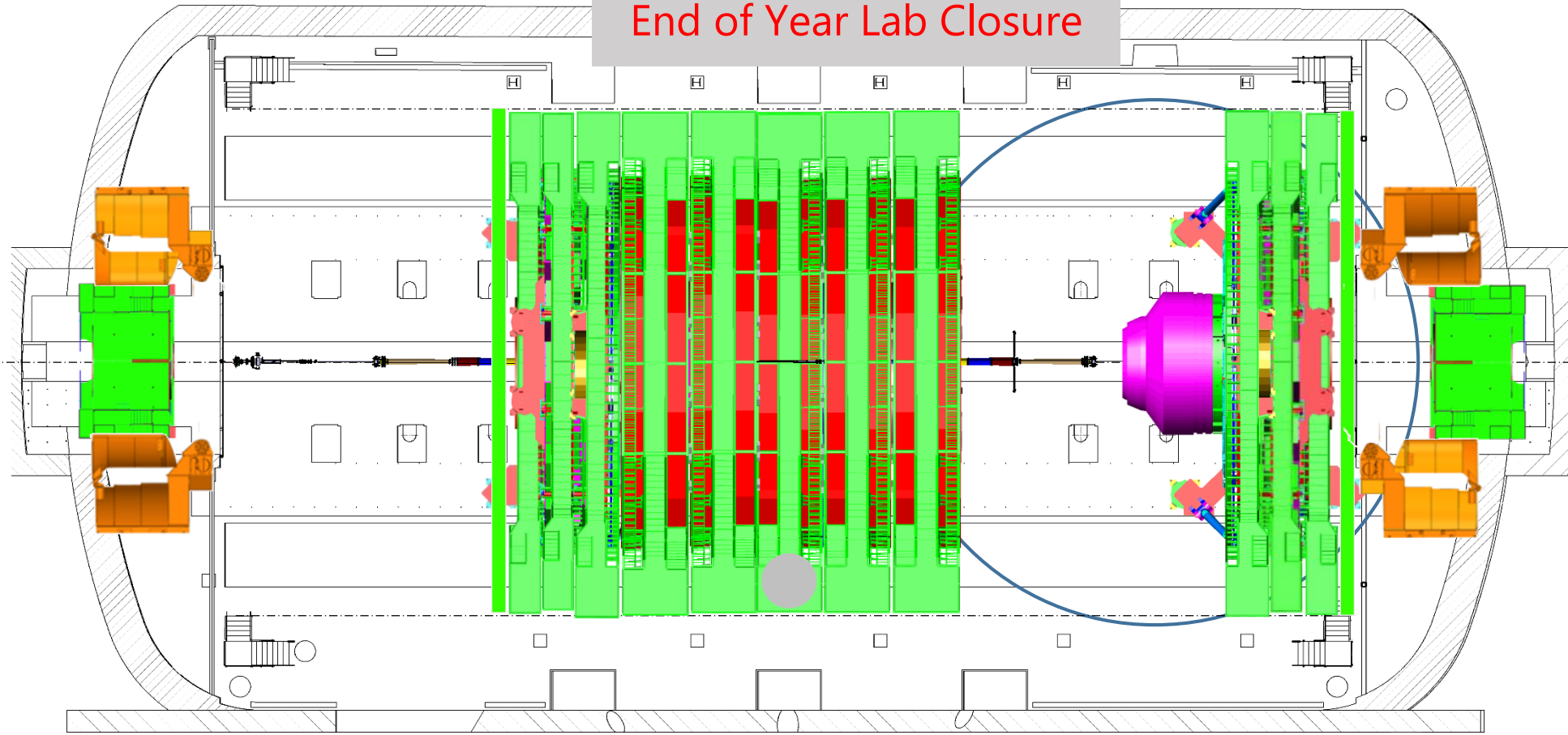

5m



Crane

Cryo.	■	EL power	■	Water cool.	■	Database	■
IT	■	Magnet	■	C6F14	■	Gas	■
SL. 0	GEM	ECAL	ZEC	DT+ RB	Survey	TE-VSC	GS Dept
CP. 0	TOTEM	CMX	CSC RE	TK PIX	HCAL	EN Dept	<b>RP</b>

PX56 Plug  
CLOSED

TX54 Plug  
CLOSED

2019

January - Week 1

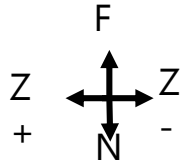

End of Year Lab Closure

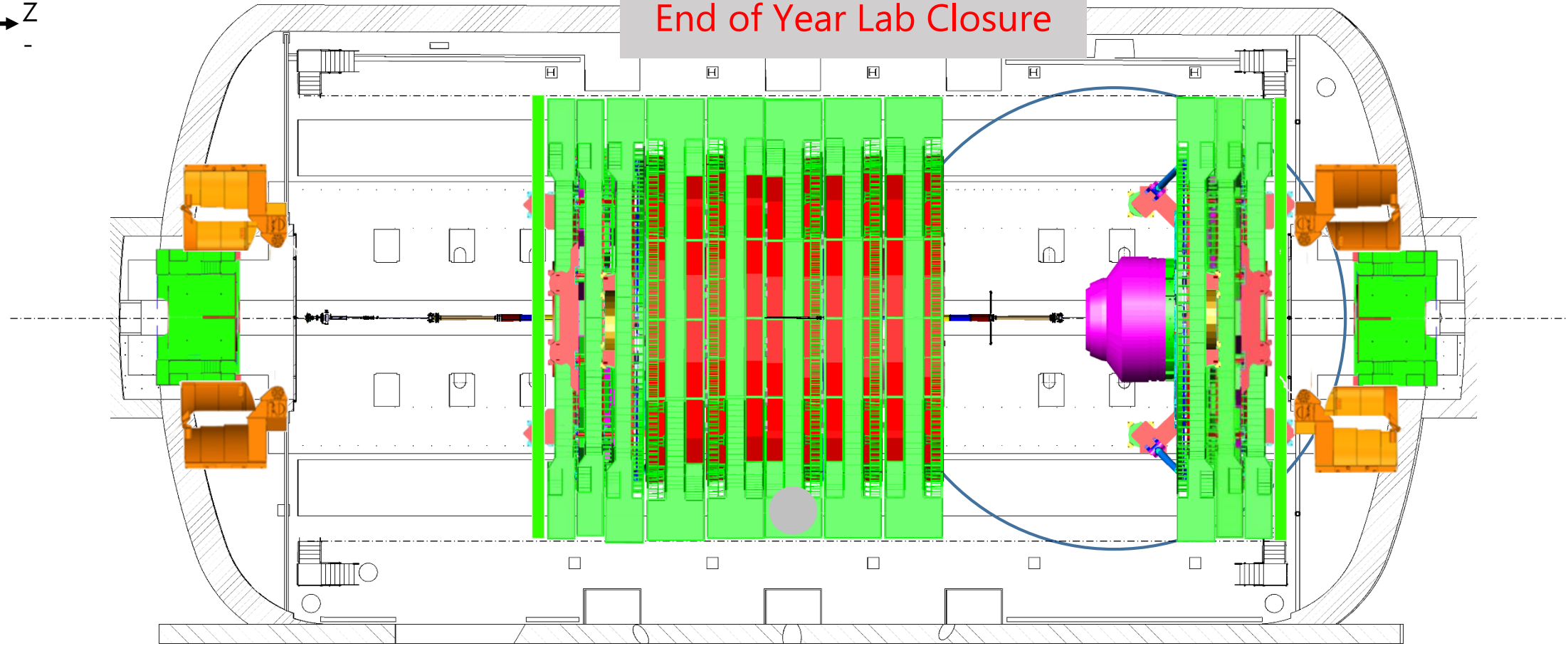

5m





Crane

Cryo.	<span style="background-color: green; color: white;">■</span>	EL power	<span style="background-color: green; color: white;">■</span>	Water cool.	<span style="background-color: yellow; color: black;">■</span>	Database	<span style="background-color: green; color: white;">■</span>
IT	<span style="background-color: green; color: white;">■</span>	Magnet	<span style="background-color: red; color: white;">■</span>	C6F14	<span style="background-color: red; color: white;">■</span>	Gas	<span style="background-color: green; color: white;">■</span>
SL. 0	GEM	ECAL	ZEC	DT+ RB	Survey	TE-VSC	GS Dept
CP. 0	TOTEM	CMX	CSC RE	TK PIX	HCAL	EN Dept	<b>RP</b>

PX56 Plug  
CLOSED

TX54 Plug  
CLOSED

2019

January - Week 2

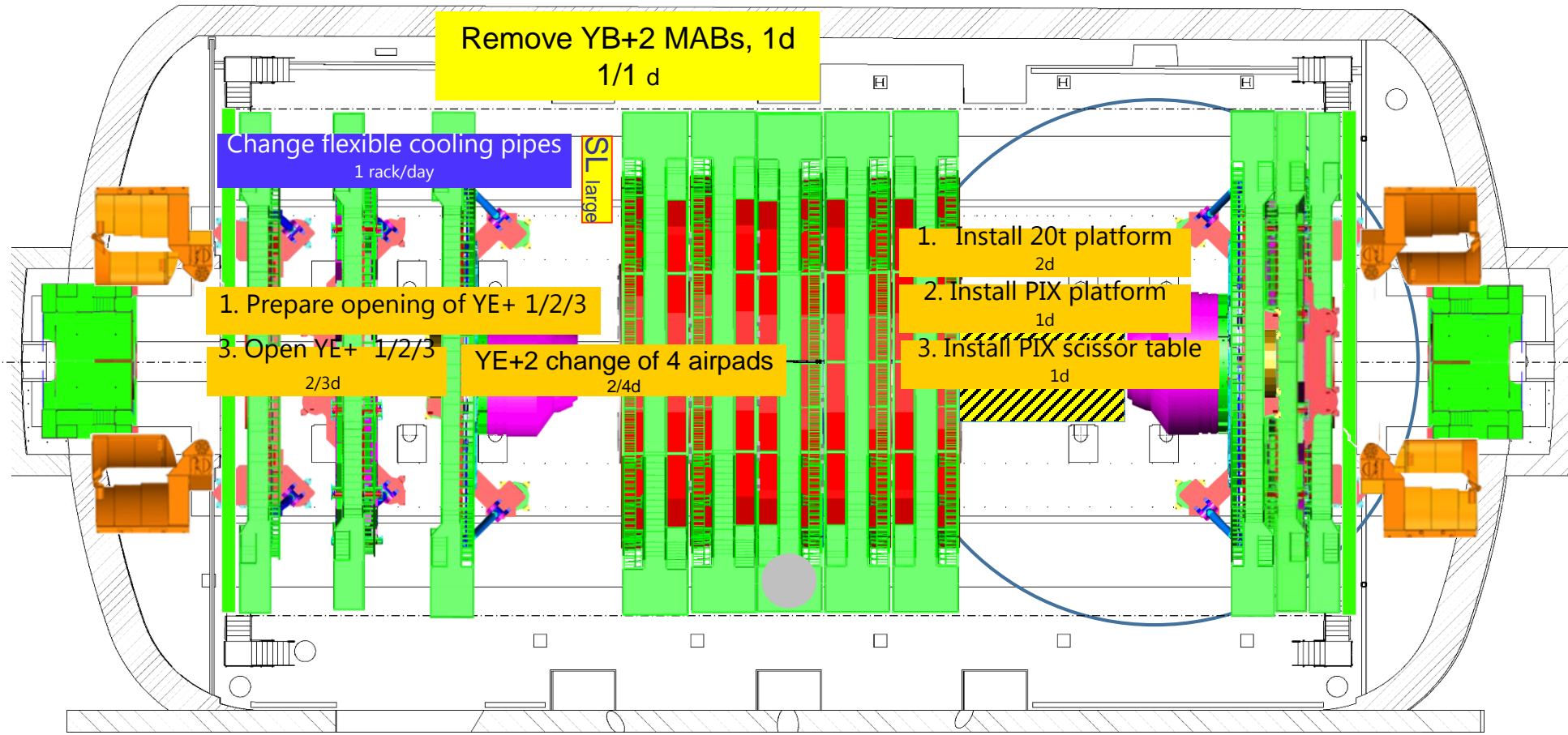
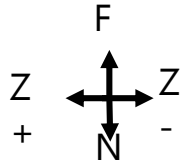

5m



Crane

Cryo.	<span style="color: green;">■</span>	EL power	<span style="color: green;">■</span>	Water cool.	<span style="color: red;">■</span>	Database	<span style="color: green;">■</span>
IT	<span style="color: green;">■</span>	Magnet	<span style="color: red;">■</span>	C6F14	<span style="color: red;">■</span>	Gas	<span style="color: green;">■</span>
SL. 0	GEM	ECAL	ZEC	DT+ RB	Survey	TE-VSC	GS Dept
CP. 0	TOTEM	CMX	CSC RE	TK PIX	HCAL	EN Dept	<b>RP</b>

PX56 Plug CLOSED
TX54 Plug CLOSED

2019
January - Week 3

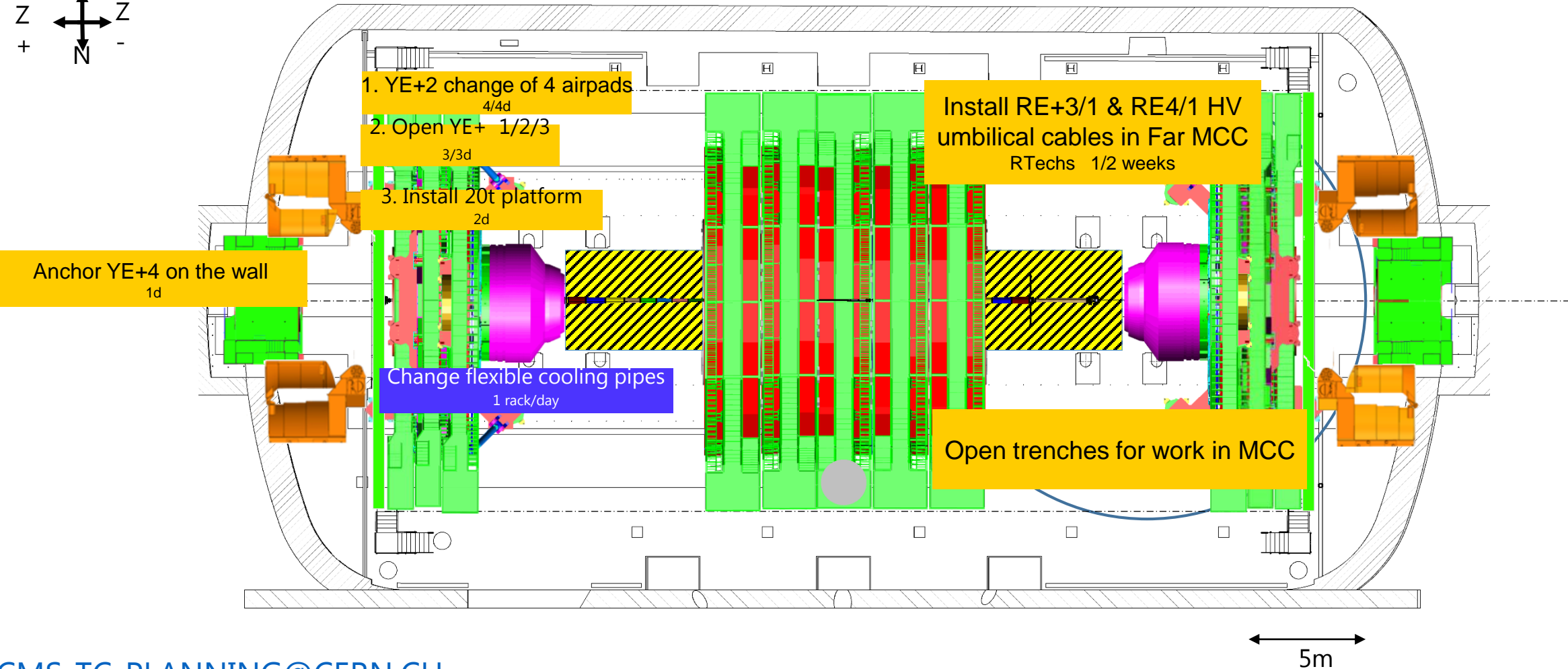
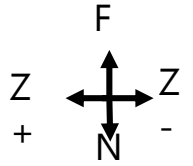





Crane

Cryo.	█	EL power	█	Water cool.	█	Database	█								
IT	█	Magnet	█	C6F14	█	Gas	█								
SL.	0	GEM	█	ECAL	█	ZEC	█	DT+ RB	█	Survey	█	TE-VSC	█	GS Dept	█
CP.	0	TOTEM	█	CMX	█	CSC RE	█	TK PIX	█	HCAL	█	EN Dept	█	<b>RP</b>	█

PX56 Plug  
CLOSED

TX54 Plug  
CLOSED

2019

January - Week 4

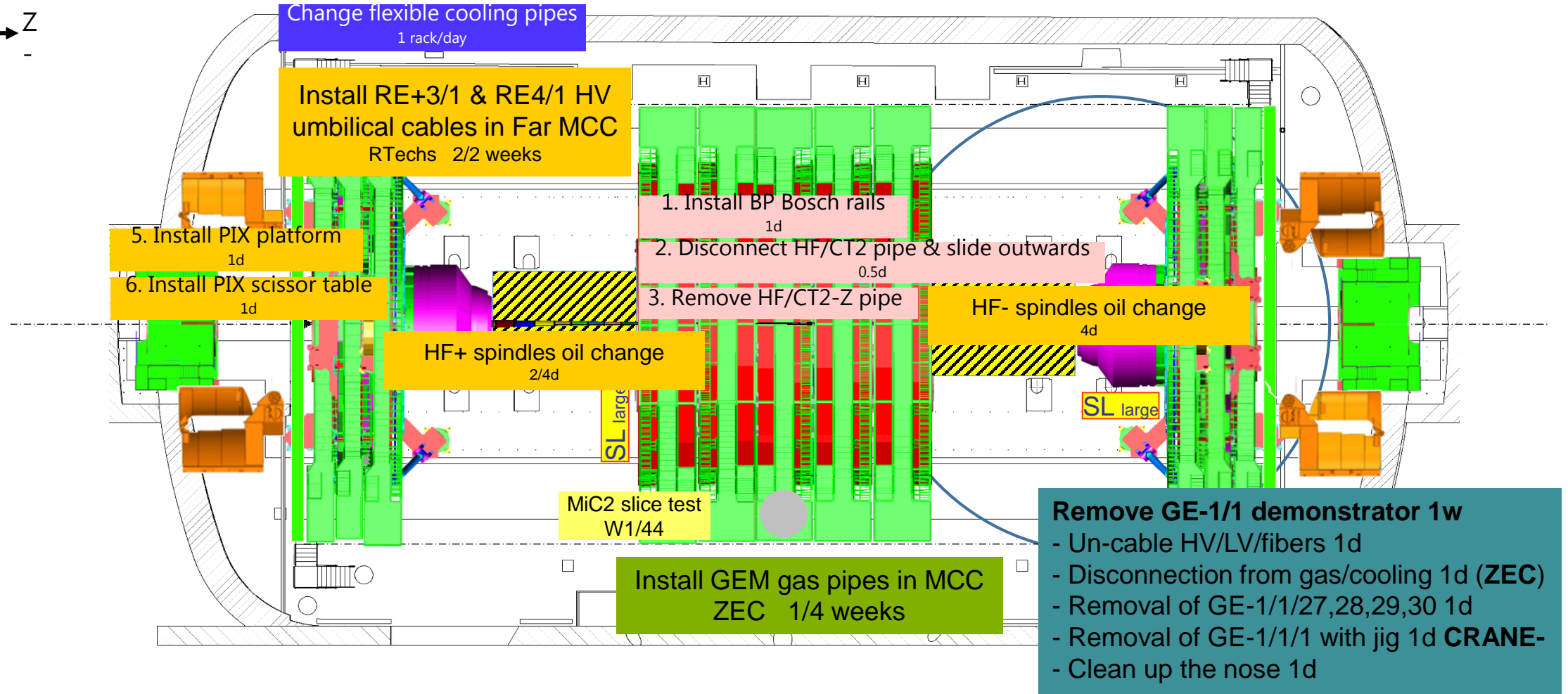



Crane

Cryo.	█	EL power	█	Water cool.	█	Database	█
IT	█	Magnet	█	C6F14	█	Gas	█
SL. 0	GEM	ECAL	ZEC	DT+ RB	Survey	TE-VSC	GS Dept
CP. 0	TOTEM	CMX	CSC RE	TK PIX	HCAL	EN Dept	<b>RP</b>

PX56 Plug  
CLOSED

TX54 Plug  
CLOSED

2019

January - Week 5

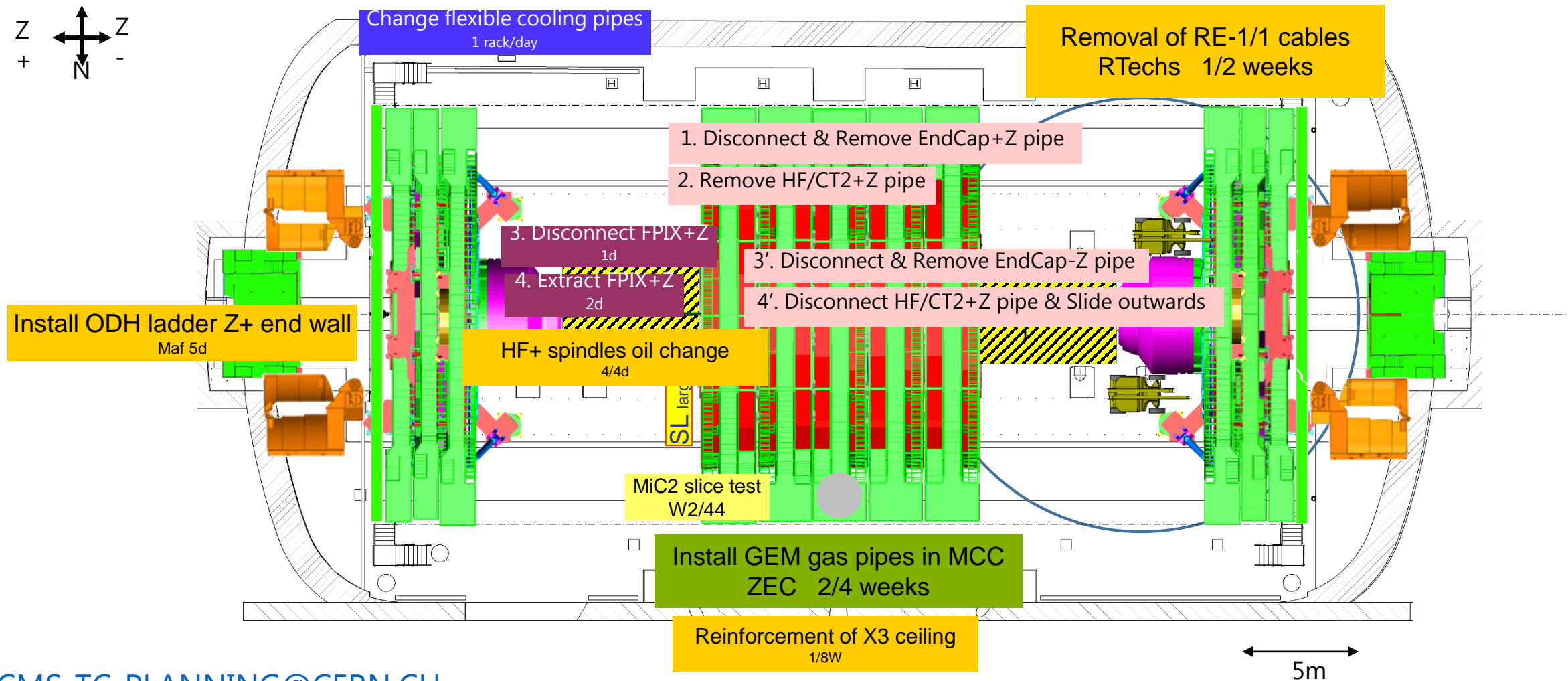
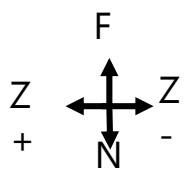



Crane

Cryo.	█	EL power	█	Water cool.	█	Database	█								
IT	█	Magnet	█	C6F14	█	Gas	█								
SL.	0	GEM	█	ECAL	█	ZEC	█	DT+ RB	█	Survey	█	TE-VSC	█	GS Dept	█
CP.	0	TOTEM	█	CMX	█	CSC RE	█	TK PIX	█	HCAL	█	EN Dept	█	<b>RP</b>	█

PX56 Plug	CLOSED
TX54 Plug	CLOSED

2019

February - Week 6

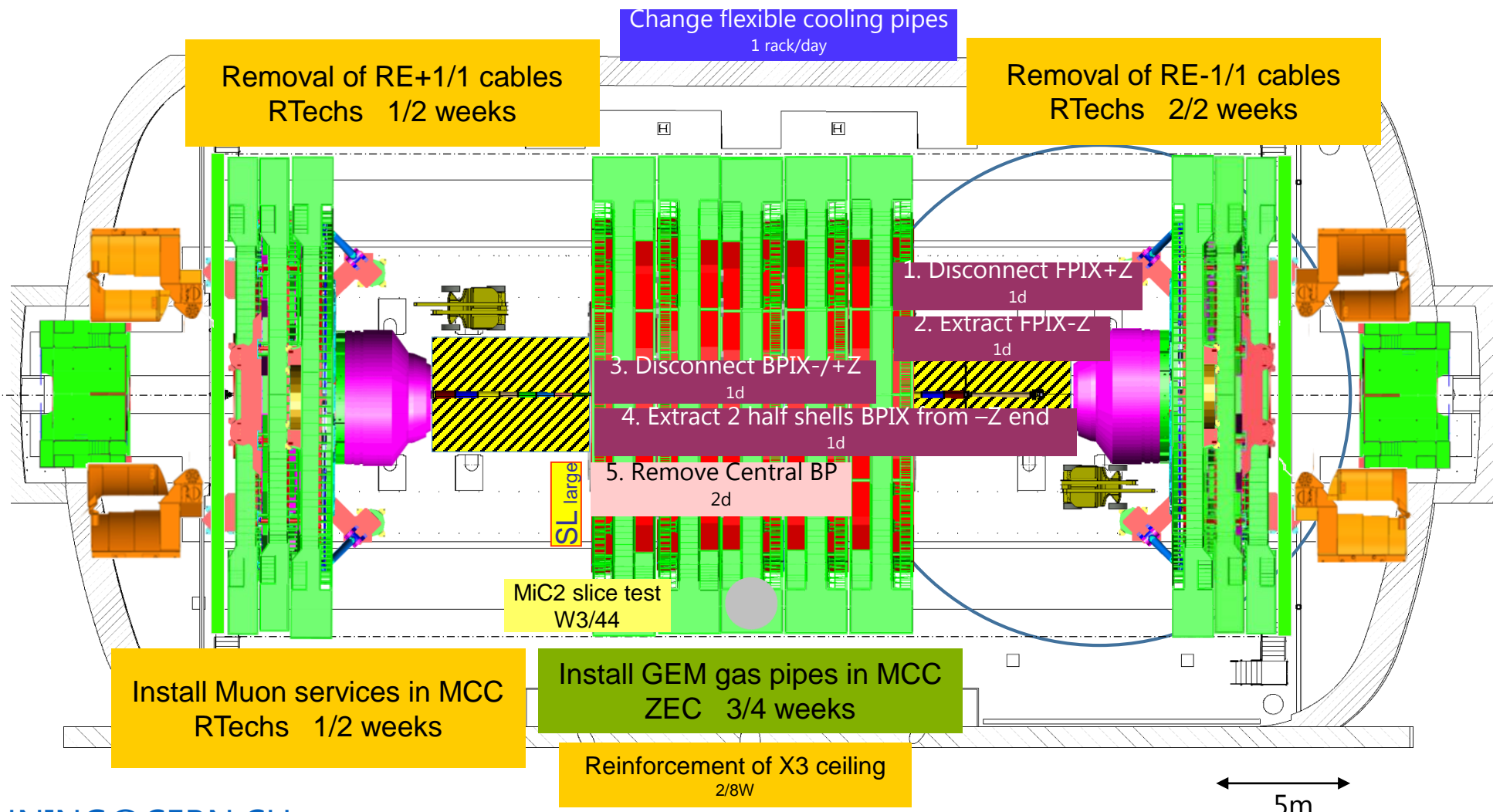
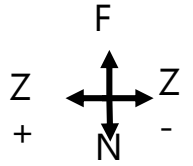



Crane

Cryo.	<span style="color: green;">■</span>	EL power	<span style="color: green;">■</span>	Water cool.	<span style="color: red;">■</span>	Database	<span style="color: green;">■</span>
IT	<span style="color: green;">■</span>	Magnet	<span style="color: red;">■</span>	C6F14	<span style="color: red;">■</span>	Gas	<span style="color: green;">■</span>
SL. 0	GEM	ECAL	ZEC	DT+ RB	Survey	TE-VSC	GS Dept
CP. 0	TOTEM	CMX	CSC RE	TK PIX	HCAL	EN Dept	<b>RP</b>

PX56 Plug  
CLOSED

TX54 Plug  
CLOSED

2019

February - Week 7

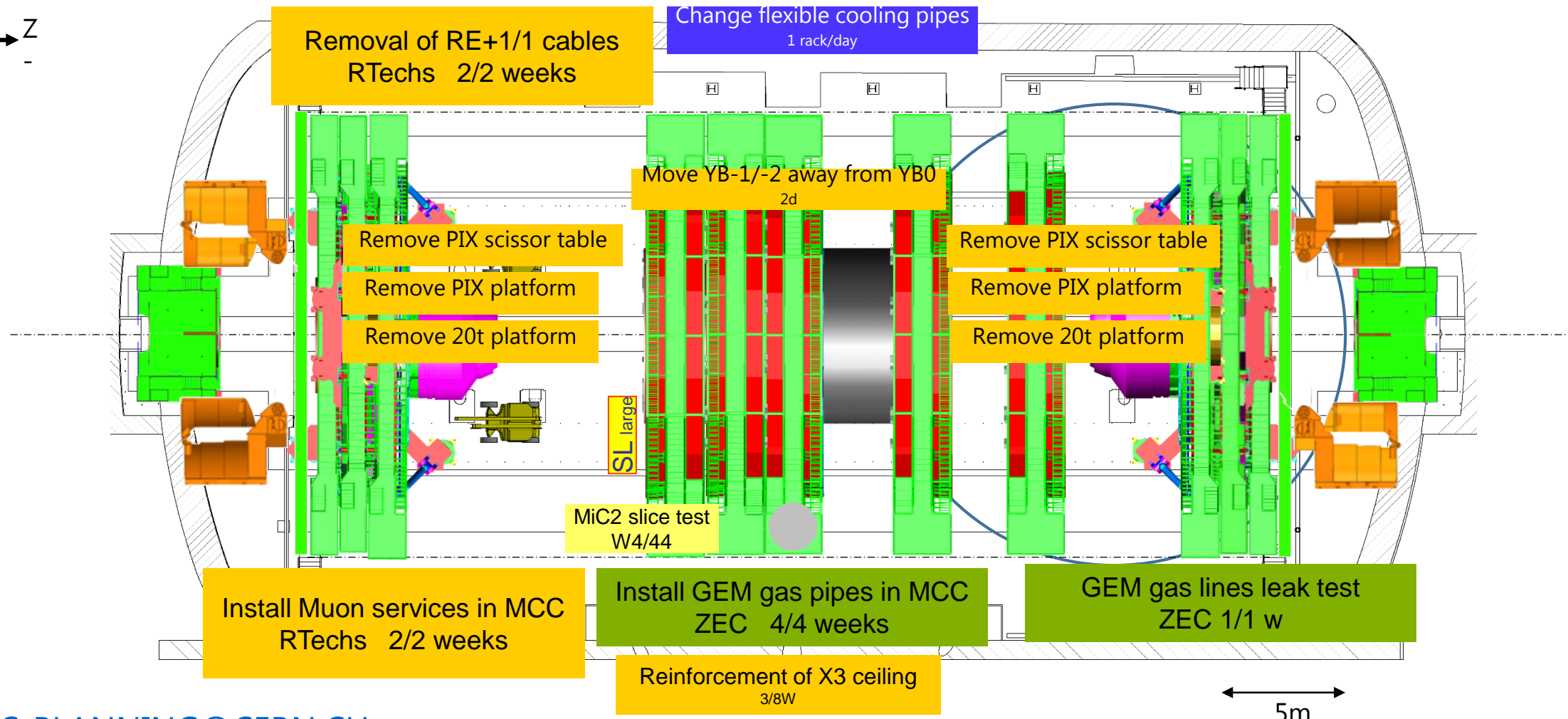
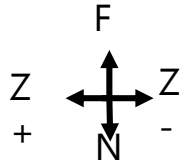



Crane

Cryo.	<span style="color: green;">■</span>	EL power	<span style="color: green;">■</span>	Water cool.	<span style="color: red;">■</span>	Database	<span style="color: green;">■</span>
IT	<span style="color: green;">■</span>	Magnet	<span style="color: red;">■</span>	C6F14	<span style="color: red;">■</span>	Gas	<span style="color: green;">■</span>
SL. 0	GEM	ECAL	ZEC	DT+ RB	Survey	TE-VSC	GS Dept
CP. 0	TOTEM	CMX	CSC RE	TK PIX	HCAL	EN Dept	<b>RP</b>

PX56 Plug CLOSED
TX54 Plug CLOSED

2019
February - Week 8

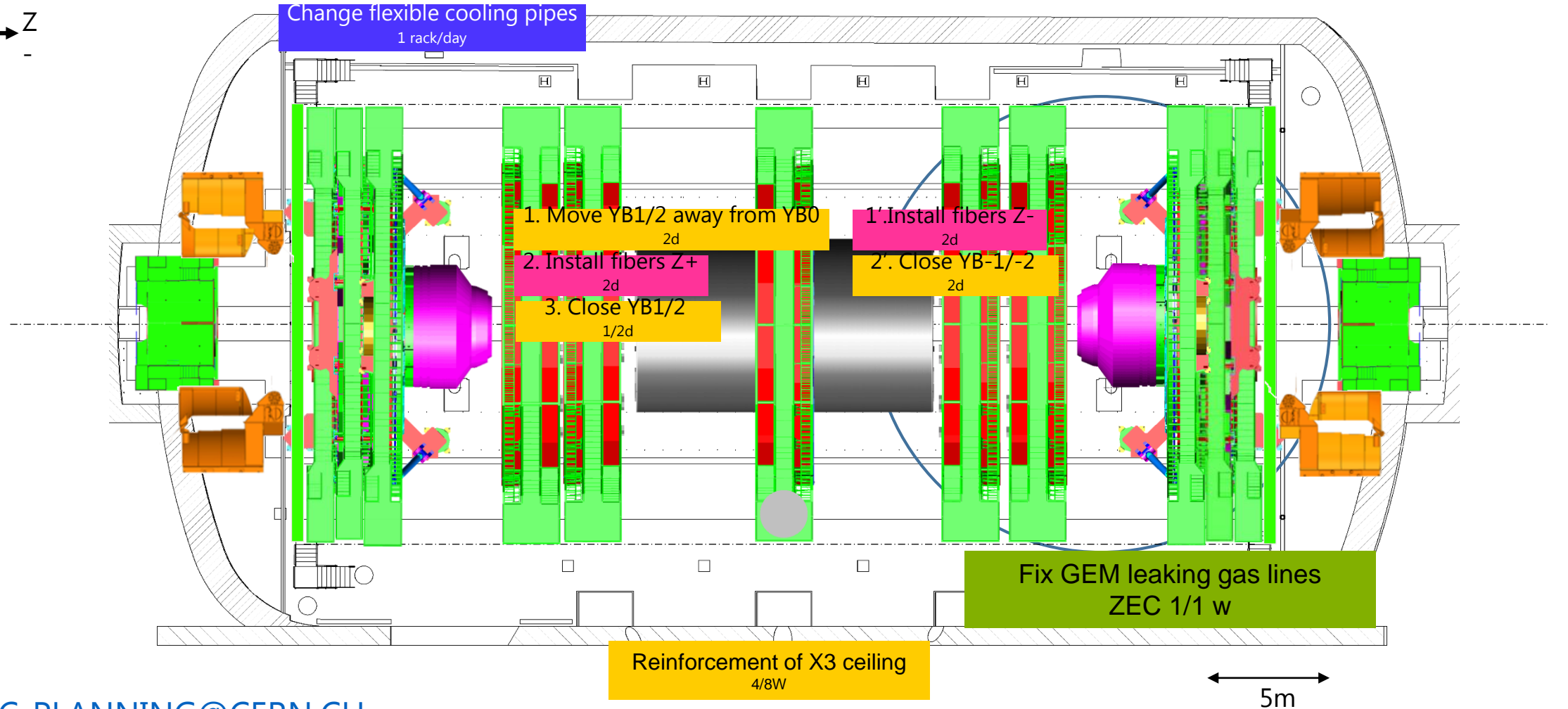
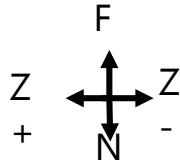





Crane

Cryo.	<span style="color: green;">■</span>	EL power	<span style="color: green;">■</span>	Water cool.	<span style="color: red;">■</span>	Database	<span style="color: green;">■</span>
IT	<span style="color: green;">■</span>	Magnet	<span style="color: red;">■</span>	C6F14	<span style="color: red;">■</span>	Gas	<span style="color: green;">■</span>
SL. 0	GEM	ECAL	ZEC	DT+ RB	Survey	TE-VSC	GS Dept
CP. 0	TOTEM	CMX	CSC RE	TK PIX	HCAL	EN Dept	<b>RP</b>

PX56 Plug  
CLOSED

2019

TX54 Plug  
CLOSED

February – Week 9

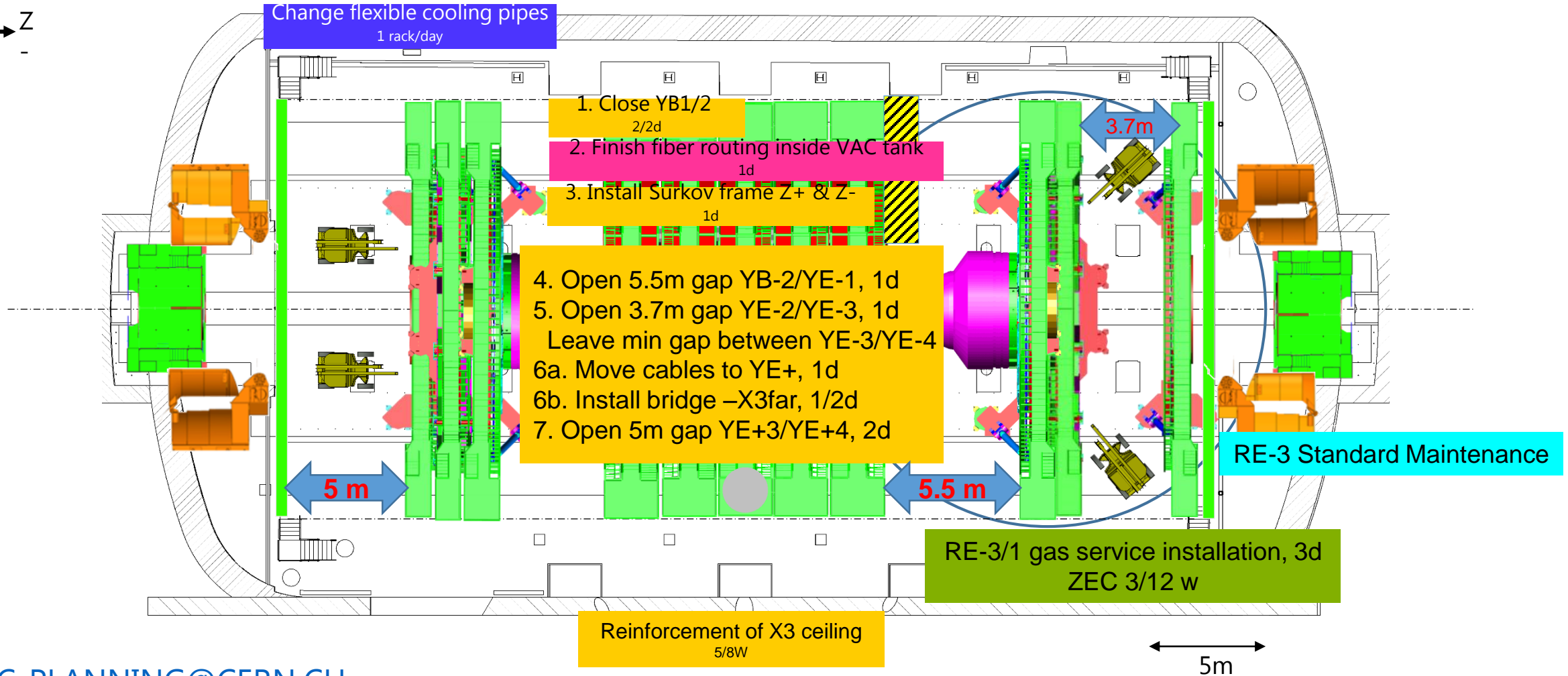
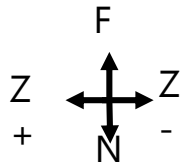



Crane

Cryo.	█	EL power	█	Water cool.	█	Database	█								
IT	█	Magnet	█	C6F14	█	Gas	█								
SL.	0	GEM	█	ECAL	█	ZEC	█	DT+ RB	█	Survey	█	TE-VSC	█	GS Dept	█
CP.	0	TOTEM	█	CMX	█	CSC RE	█	TK PIX	█	HCAL	█	EN Dept	█	<b>RP</b>	█

PX56 Plug  
CLOSED

2019

TX54 Plug  
CLOSED

March – Week 10

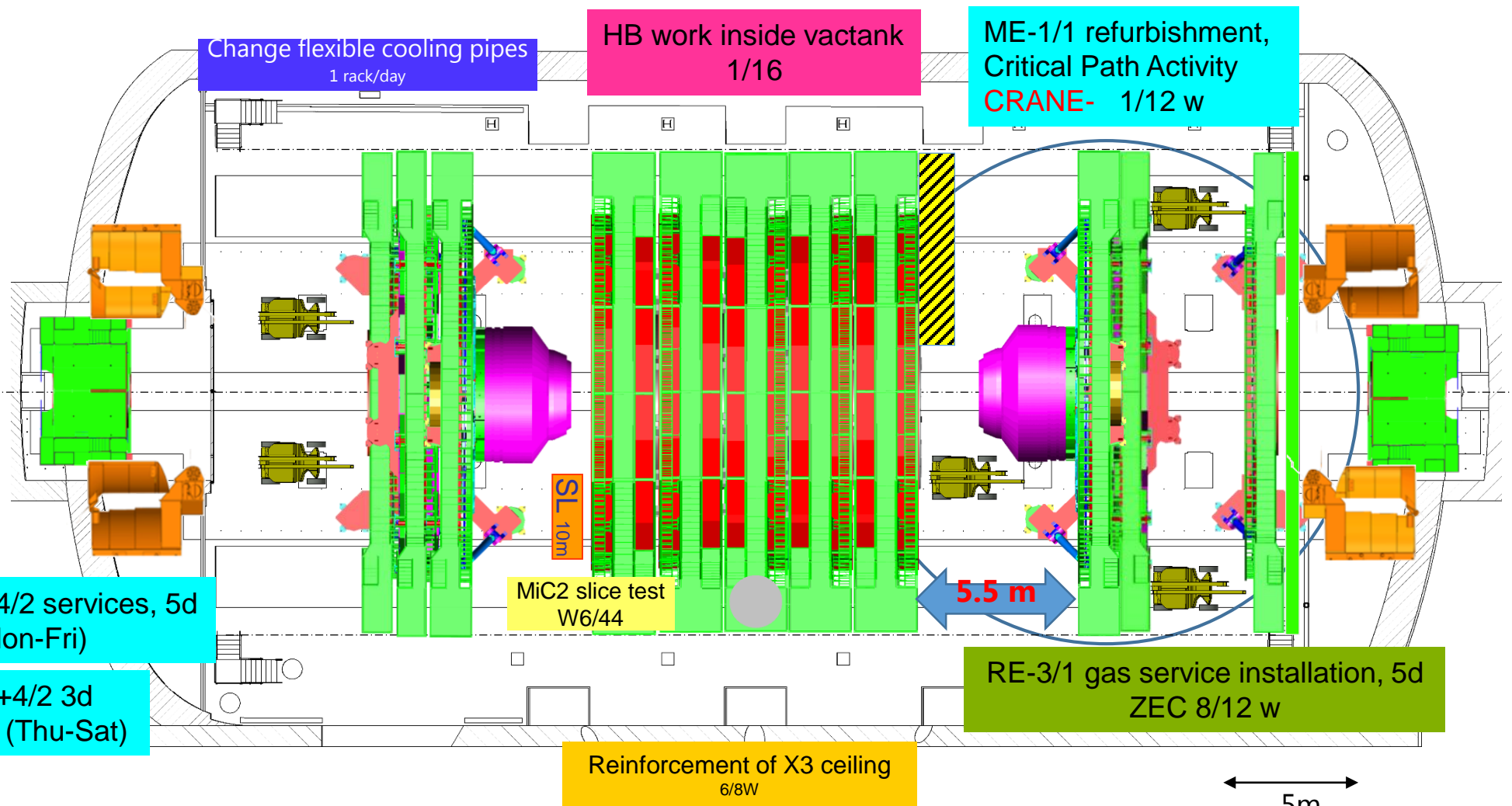
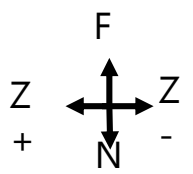



Crane

Cryo.	<span style="background-color: green; color: green;">█</span>	EL power	<span style="background-color: green; color: green;">█</span>	Water cool.	<span style="background-color: green; color: green;">█</span>	Database	<span style="background-color: green; color: green;">█</span>	
IT	<span style="background-color: green; color: green;">█</span>	Magnet	<span style="background-color: red; color: red;">█</span>	C6F14	<span style="background-color: green; color: green;">█</span>	Gas	<span style="background-color: green; color: green;">█</span>	
SL.	0	GEM	ECAL	ZEC	DT+ RB	Survey	TE-VSC	GS Dept
CP.	0	TOTEM	CMX	CSC RE	TK PIX	HCAL	EN Dept	<b>RP</b>

PX56 Plug CLOSED
TX54 Plug CLOSED

2019
March – Week 11

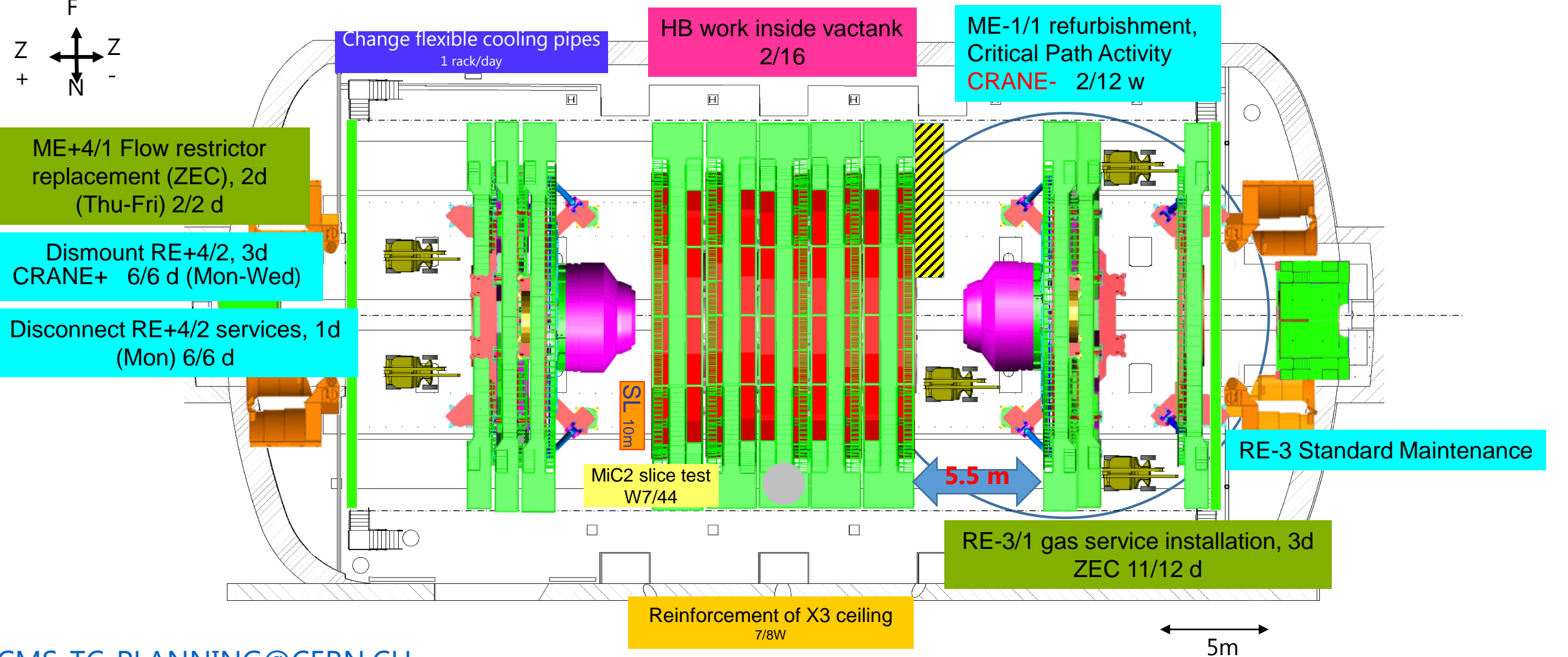
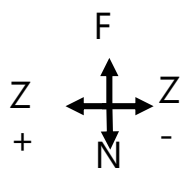





2019

March – Week 12

Cryo.	<span style="background-color: green; width: 15px; height: 15px; display: inline-block;"></span>	EL power	<span style="background-color: green; width: 15px; height: 15px; display: inline-block;"></span>	Water cool.	<span style="background-color: green; width: 15px; height: 15px; display: inline-block;"></span>	Database	<span style="background-color: green; width: 15px; height: 15px; display: inline-block;"></span>	
IT	<span style="background-color: green; width: 15px; height: 15px; display: inline-block;"></span>	Magnet	<span style="background-color: red; width: 15px; height: 15px; display: inline-block;"></span>	C6F14	<span style="background-color: green; width: 15px; height: 15px; display: inline-block;"></span>	Gas	<span style="background-color: green; width: 15px; height: 15px; display: inline-block;"></span>	
SL.	0	GEM	ECAL	ZEC	DT+ RB	Survey	TE-VSC	GS Dept
CP.	0	TOTEM	CMX	CSC RE	TK PIX	HCAL	EN Dept	<b>RP</b>

PX56 Plug  
CLOSED

TX54 Plug  
CLOSED

Crane

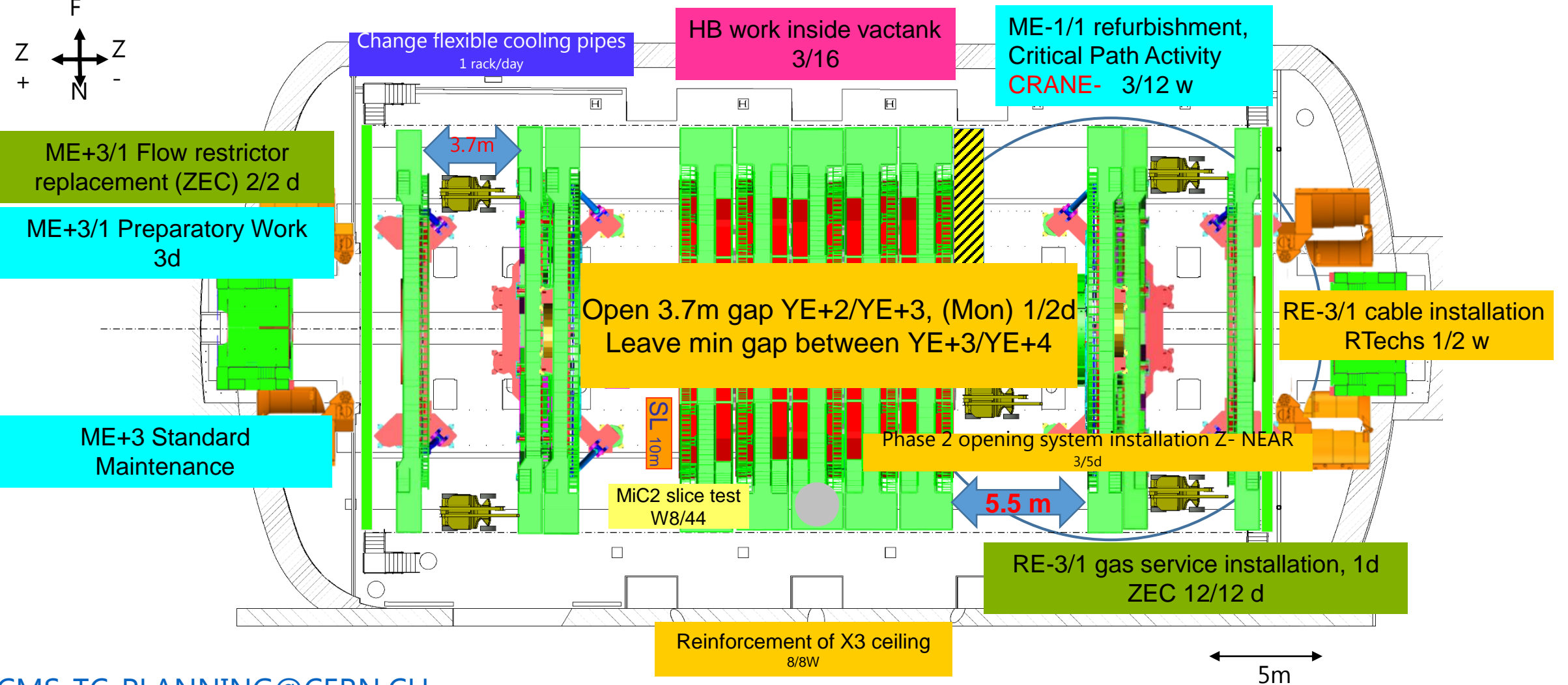
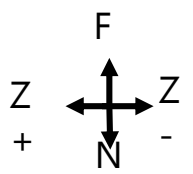



Crane

Cryo.	█	EL power	█	Water cool.	█	Database	█								
IT	█	Magnet	█	C6F14	█	Gas	█								
SL.	0	GEM	█	ECAL	█	ZEC	█	DT+ RB	█	Survey	█	TE-VSC	█	GS Dept	█
CP.	0	TOTEM	█	CMX	█	CSC RE	█	TK PIX	█	HCAL	█	EN Dept	█	<b>RP</b>	█

PX56 Plug  
CLOSED

2019

TX54 Plug  
CLOSED

March – Week 13

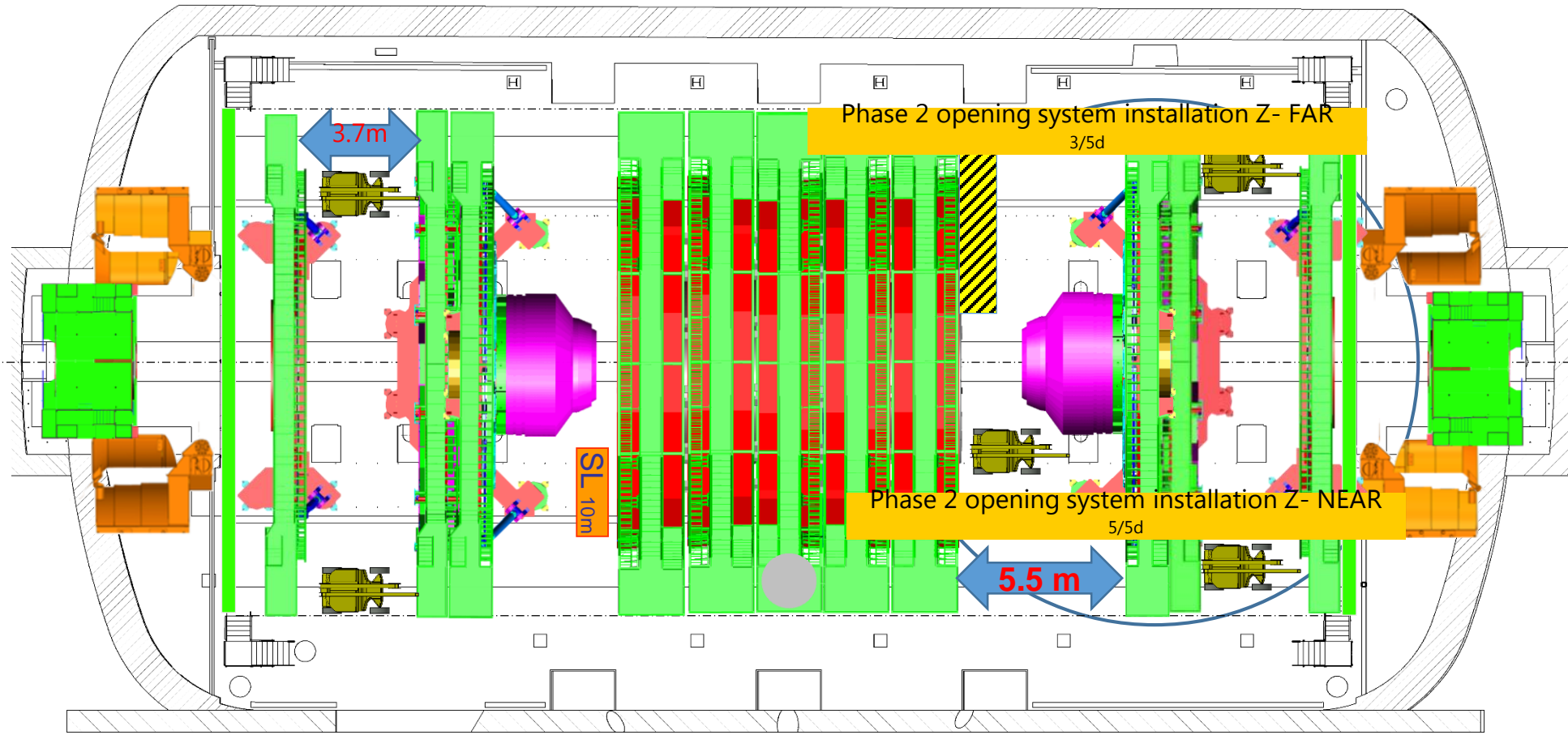
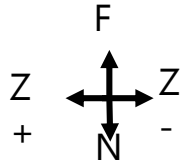

5m



Cryo.	█	EL power	█	Water cool.	█	Database	█
IT	█	Magnet	█	C6F14	█	Gas	█
SL. 0	GEM	ECAL	ZEC	DT+ RB	Survey	TE-VSC	GS Dept
CP. 0	TOTEM	CMX	CSC RE	TK PIX	HCAL	EN Dept	<b>RP</b>

PX56 Plug  
CLOSED

TX54 Plug  
CLOSED

2019

April – Week 14

Crane

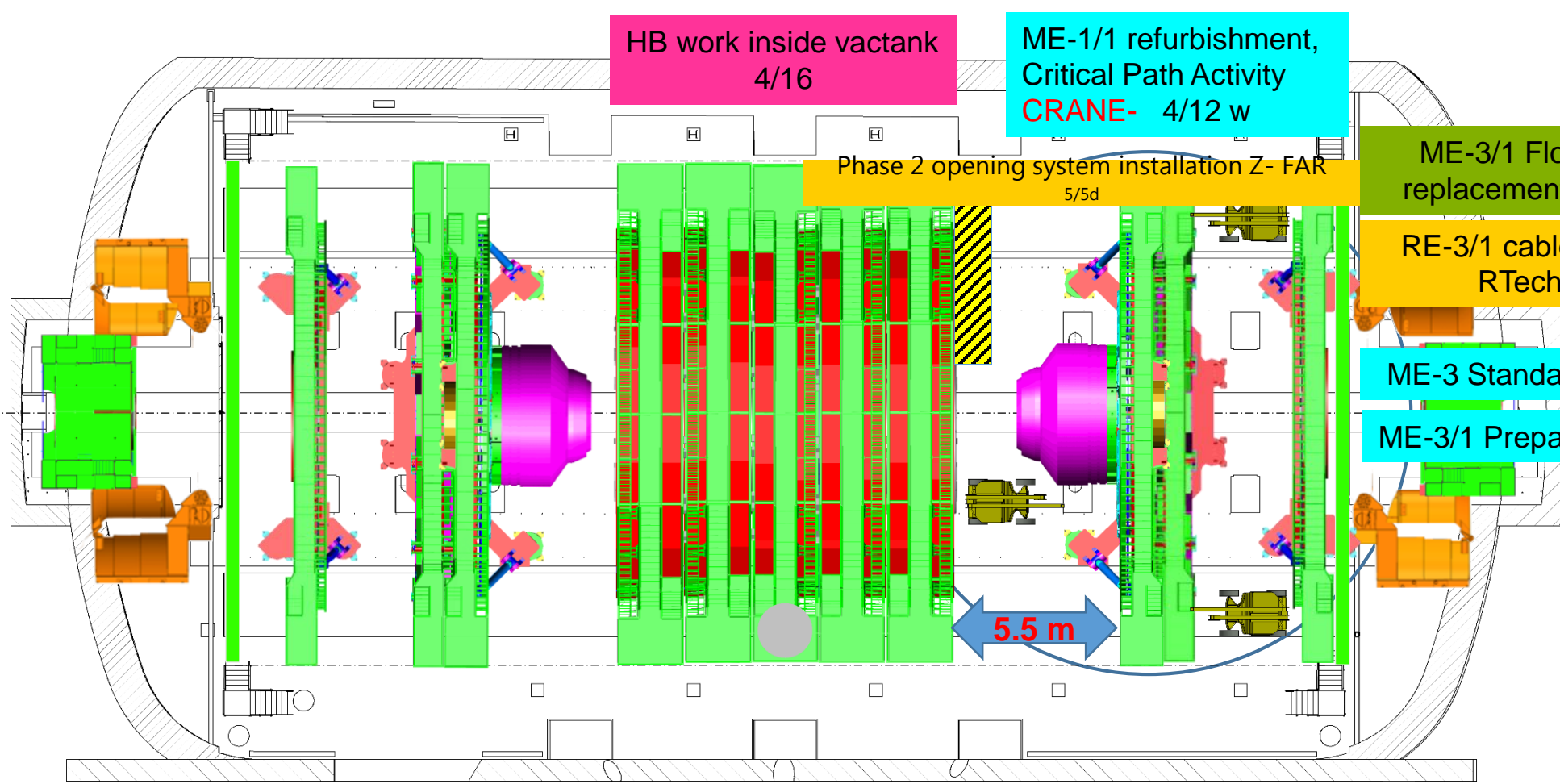
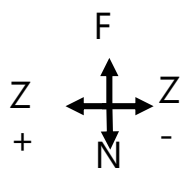

HB work inside vactank  
4/16

ME-1/1 refurbishment,  
Critical Path Activity  
**CRANE-** 4/12 w

Phase 2 opening system installation Z- FAR  
5/5d

ME-3/1 Flow restrictor  
replacement (ZEC) 2/2 d

RE-3/1 cable installation  
RTechs 2/2 w

ME-3 Standard Maintenance

ME-3/1 Preparatory Work 3d

5.5 m

5m



Crane

Cryo.	█	EL power	█	Water cool.	█	Database	█								
IT	█	Magnet	█	C6F14	█	Gas	█								
SL.	0	GEM	█	ECAL	█	ZEC	█	DT+ RB	█	Survey	█	TE-VSC	█	GS Dept	█
CP.	0	TOTEM	█	CMX	█	CSC RE	█	TK PIX	█	HCAL	█	EN Dept	█	RP	█

PX56 Plug  
CLOSED

TX54 Plug  
CLOSED

2019

April – Week 15

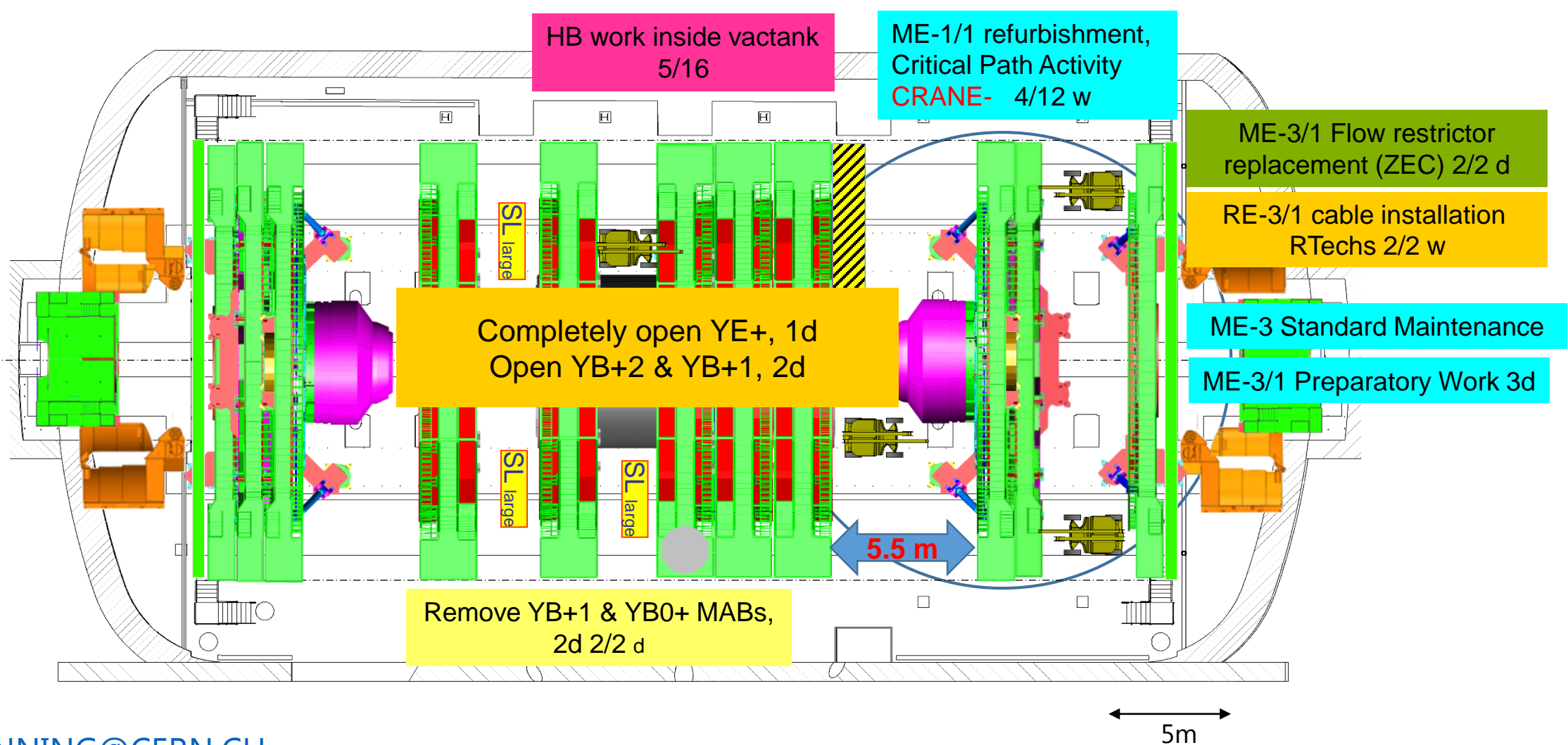
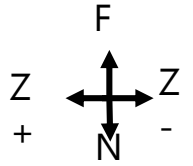





Crane

Cryo.		EL power		Water cool.		Database		
IT		Magnet		C6F14		Gas		
SL.	0	GEM	ECAL	ZEC	DT+ RB	Survey	TE-VSC	GS Dept
CP.	0	TOTEM	CMX	CSC RE	TK PIX	HCAL	EN Dept	<b>RP</b>

PX56 Plug CLOSED	2019
TX54 Plug CLOSED	April – Week 16

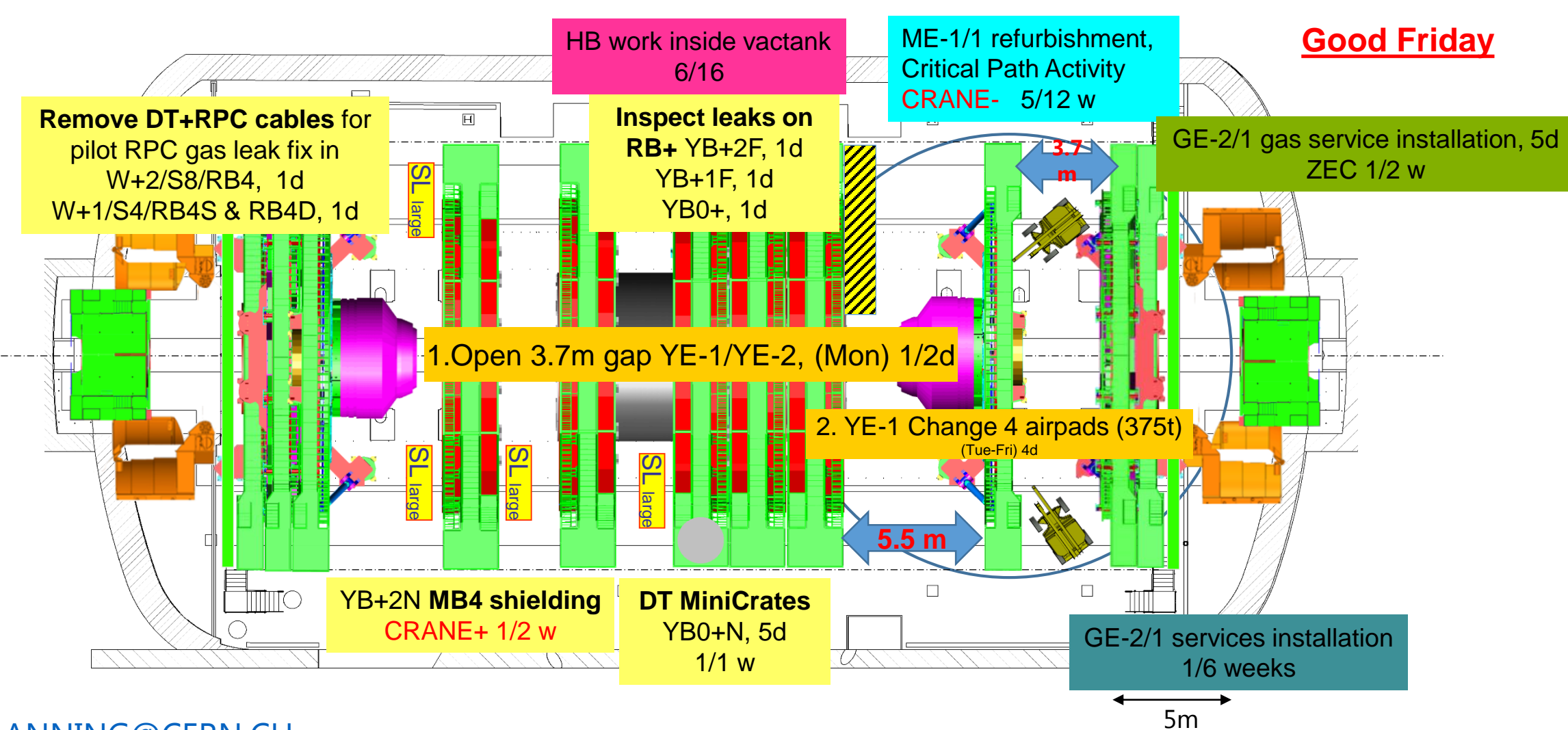
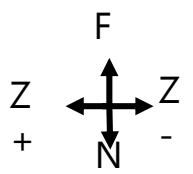

**Good Friday**



Crane

Cryo.	<span style="background-color: green; color: green;">█</span>	EL power	<span style="background-color: green; color: green;">█</span>	Water cool.	<span style="background-color: green; color: green;">█</span>	Database	<span style="background-color: green; color: green;">█</span>
IT	<span style="background-color: green; color: green;">█</span>	Magnet	<span style="background-color: red; color: red;">█</span>	C6F14	<span style="background-color: green; color: green;">█</span>	Gas	<span style="background-color: green; color: green;">█</span>
SL. 0	<span style="background-color: teal; color: white;">GEM</span>	<span style="background-color: blue; color: white;">ECAL</span>	<span style="background-color: green; color: white;">ZEC</span>	<span style="background-color: yellow; color: black;">DT+ RB</span>	<span style="background-color: grey; color: white;">Survey</span>	<span style="background-color: pink; color: black;">TE-VSC</span>	<span style="background-color: brown; color: white;">GS Dept</span>
CP. 0	<span style="background-color: olive; color: white;">TOTEM</span>	<span style="background-color: yellow; color: black;">CMX</span>	<span style="background-color: cyan; color: black;">CSC RE</span>	<span style="background-color: purple; color: white;">TK PIX</span>	<span style="background-color: magenta; color: black;">HCAL</span>	<span style="background-color: orange; color: black;">EN Dept</span>	<span style="border: 2px solid black; padding: 2px;"><b>RP</b></span>

PX56 Plug CLOSED
TX54 Plug CLOSED

2019
April – Week 17

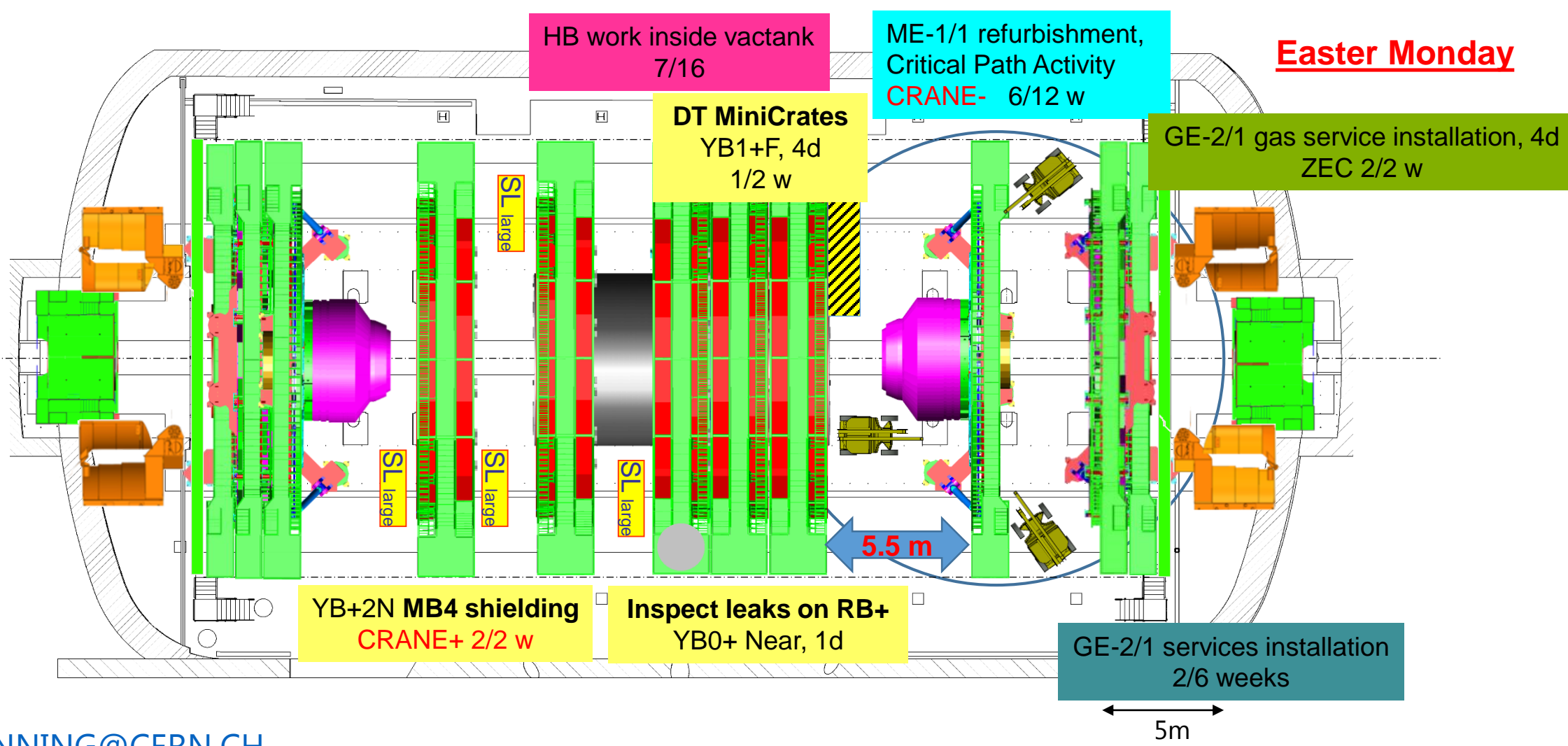
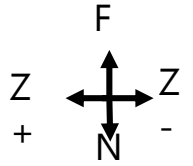



Crane

Cryo.	█	EL power	█	Water cool.	█	Database	█								
IT	█	Magnet	█	C6F14	█	Gas	█								
SL.	0	GEM	█	ECAL	█	ZEC	█	DT+ RB	█	Survey	█	TE-VSC	█	GS Dept	█
CP.	0	TOTEM	█	CMX	█	CSC RE	█	TK PIX	█	HCAL	█	EN Dept	█	<b>RP</b>	█

PX56 Plug	CLOSED
TX54 Plug	CLOSED

2019
April – Week 18

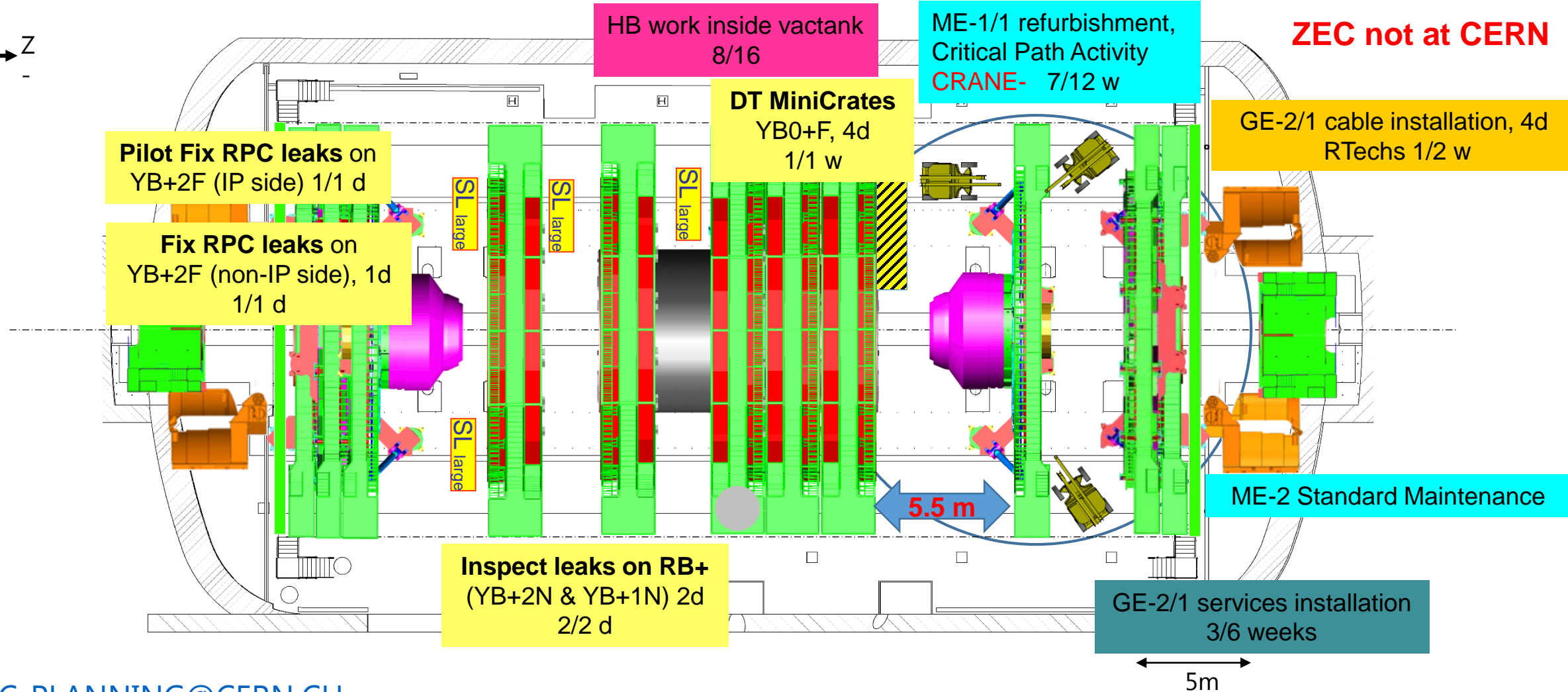
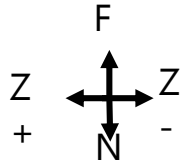



Crane

Cryo.	<span style="background-color: green; color: white;">■</span>	EL power	<span style="background-color: green; color: white;">■</span>	Water cool.	<span style="background-color: green; color: white;">■</span>	Database	<span style="background-color: green; color: white;">■</span>
IT	<span style="background-color: green; color: white;">■</span>	Magnet	<span style="background-color: red; color: white;">■</span>	C6F14	<span style="background-color: green; color: white;">■</span>	Gas	<span style="background-color: green; color: white;">■</span>
SL. 0	<span style="background-color: teal; color: white;">■</span> GEM	<span style="background-color: blue; color: white;">■</span> ECAL	<span style="background-color: green; color: white;">■</span> ZEC	<span style="background-color: yellow; color: black;">■</span> DT+ RB	<span style="background-color: grey; color: white;">■</span> Survey	<span style="background-color: pink; color: black;">■</span> TE-VSC	<span style="background-color: brown; color: white;">■</span> GS Dept
CP. 0	<span style="background-color: olive; color: white;">■</span> TOTEM	<span style="background-color: yellow; color: black;">■</span> CMX	<span style="background-color: cyan; color: black;">■</span> CSC RE	<span style="background-color: purple; color: white;">■</span> TK PIX	<span style="background-color: magenta; color: black;">■</span> HCAL	<span style="background-color: orange; color: black;">■</span> EN Dept	<span style="border: 2px solid black; background-color: white; color: black;">■</span> RP

PX56 Plug  
CLOSED

TX54 Plug  
CLOSED

2019

May – Week 19

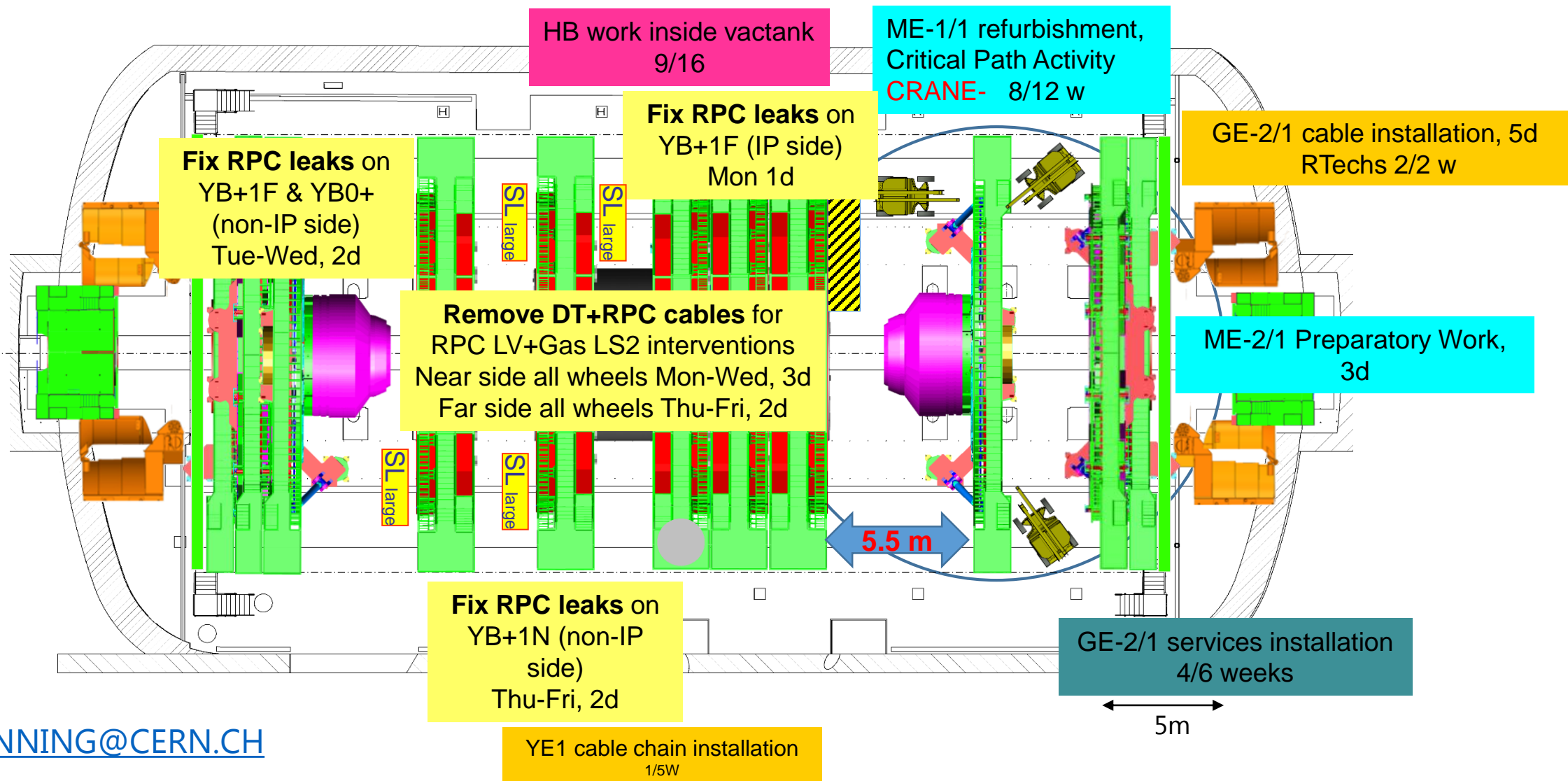
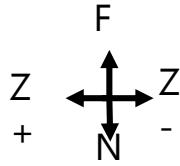





Cryo.	<span style="background-color: green; color: green;">█</span>	EL power	<span style="background-color: green; color: green;">█</span>	Water cool.	<span style="background-color: green; color: green;">█</span>	Database	<span style="background-color: green; color: green;">█</span>
IT	<span style="background-color: green; color: green;">█</span>	Magnet	<span style="background-color: red; color: red;">█</span>	C6F14	<span style="background-color: green; color: green;">█</span>	Gas	<span style="background-color: green; color: green;">█</span>
SL. 0	<span style="background-color: teal; color: white;">GEM</span>	<span style="background-color: blue; color: white;">ECAL</span>	<span style="background-color: green; color: white;">ZEC</span>	<span style="background-color: yellow; color: black;">DT+ RB</span>	<span style="background-color: grey; color: white;">Survey</span>	<span style="background-color: pink; color: black;">TE-VSC</span>	<span style="background-color: brown; color: white;">GS Dept</span>
CP. 0	<span style="background-color: olive; color: white;">TOTEM</span>	<span style="background-color: yellow; color: black;">CMX</span>	<span style="background-color: cyan; color: black;">CSC RE</span>	<span style="background-color: purple; color: white;">TK PIX</span>	<span style="background-color: magenta; color: black;">HCAL</span>	<span style="background-color: orange; color: black;">EN Dept</span>	<span style="background-color: white; border: 2px solid black; color: black; font-weight: bold;">RP</span>

PX56 Plug  
CLOSED

2019

TX54 Plug  
CLOSED

May – Week 20

Crane

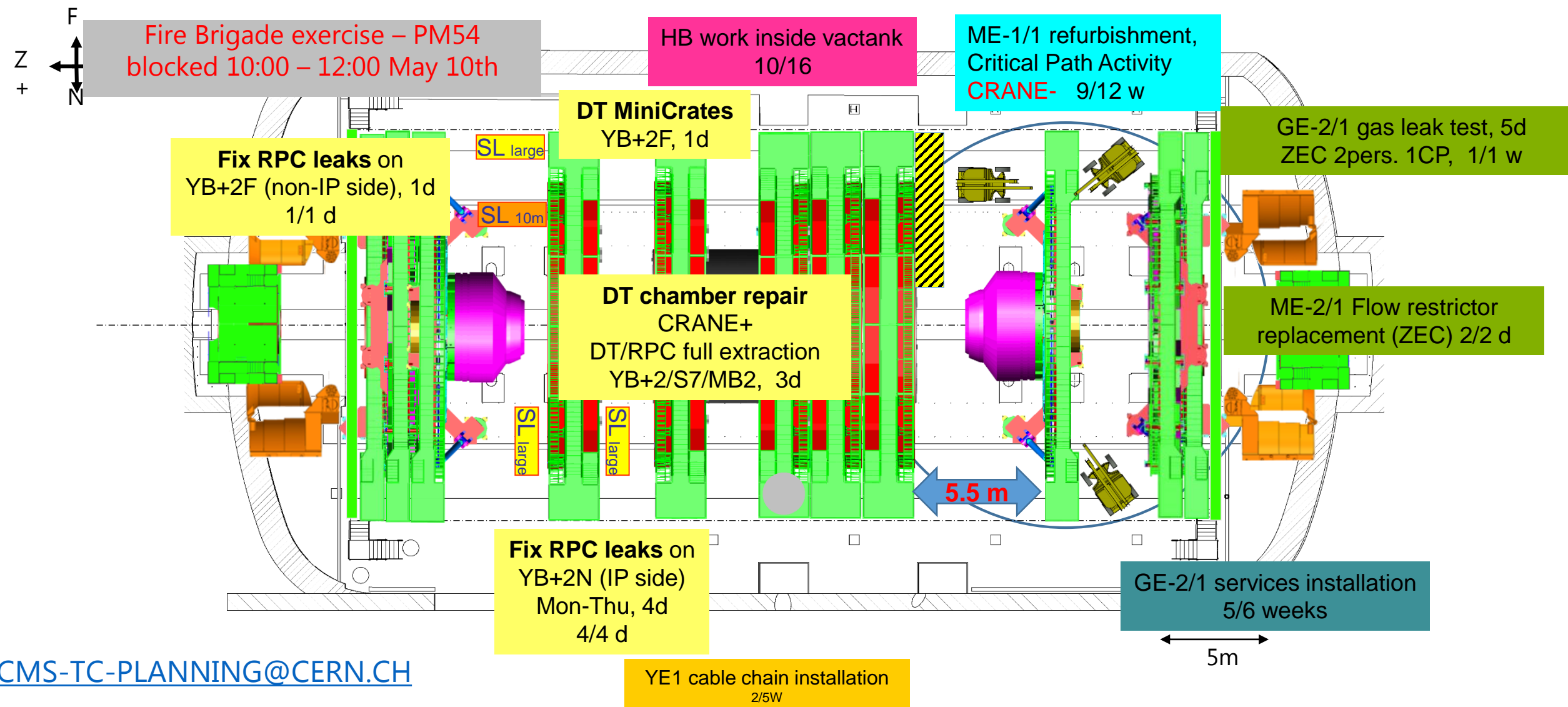



Crane

Cryo.	■	EL power	■	Water cool.	■	Database	■
IT	■	Magnet	■	C6F14	■	Gas	■
SL. 0	GEM	ECAL	ZEC	DT+ RB	Survey	TE-VSC	GS Dept
CP. 0	TOTEM	CMX	CSC RE	TK PIX	HCAL	EN Dept	<b>RP</b>

PX56 Plug  
CLOSED

TX54 Plug  
CLOSED

2019

May – Week 21

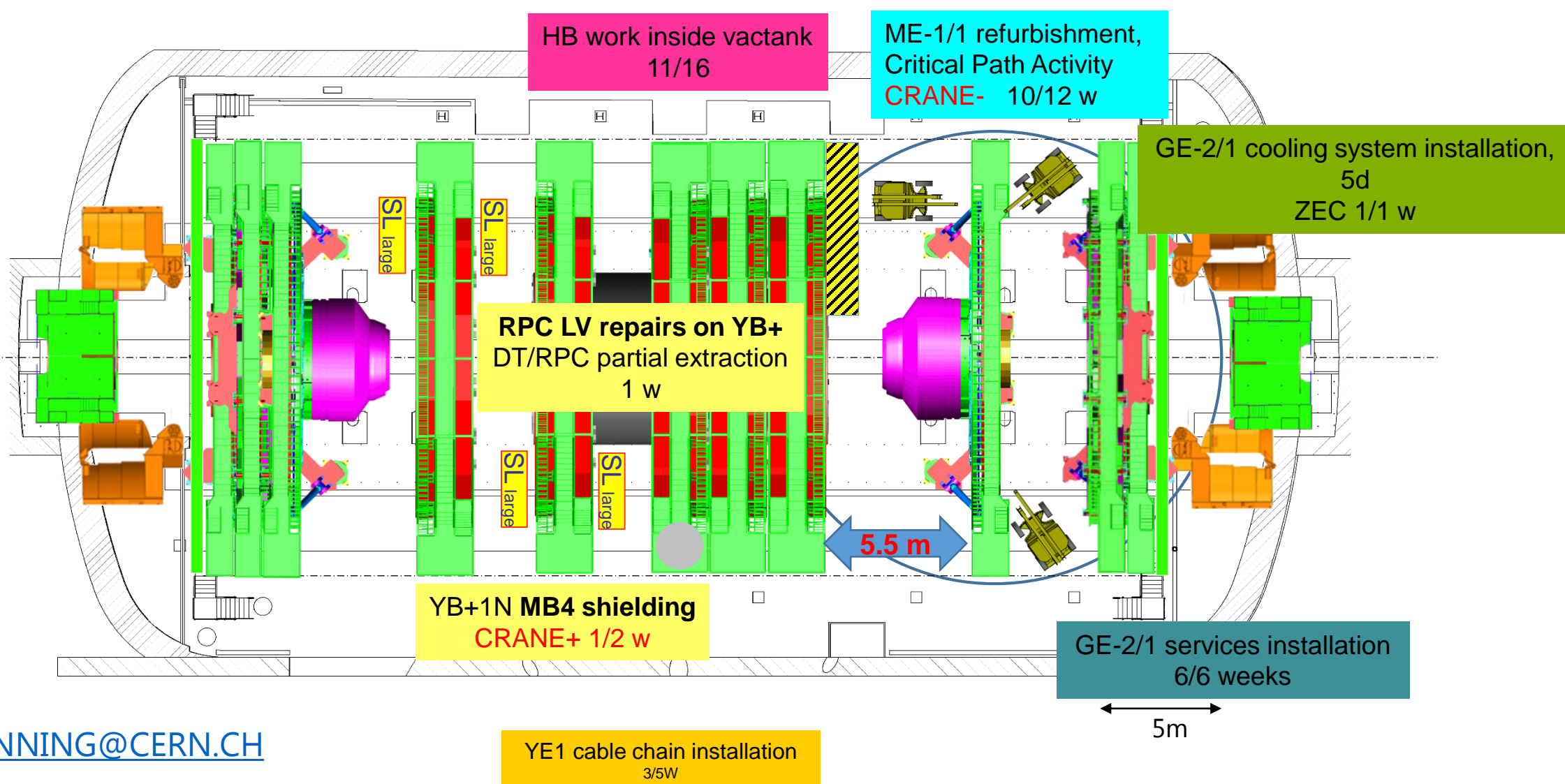
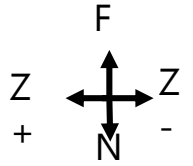



Crane

Cryo.	█	EL power	█	Water cool.	█	Database	█
IT	█	Magnet	█	C6F14	█	Gas	█
SL. 0	GEM	ECAL	ZEC	DT+ RB	Survey	TE-VSC	GS Dept
CP. 0	TOTEM	CMX	CSC RE	TK PIX	HCAL	EN Dept	<b>RP</b>

PX56 Plug CLOSED

2019

TX54 Plug CLOSED

May – Week 22

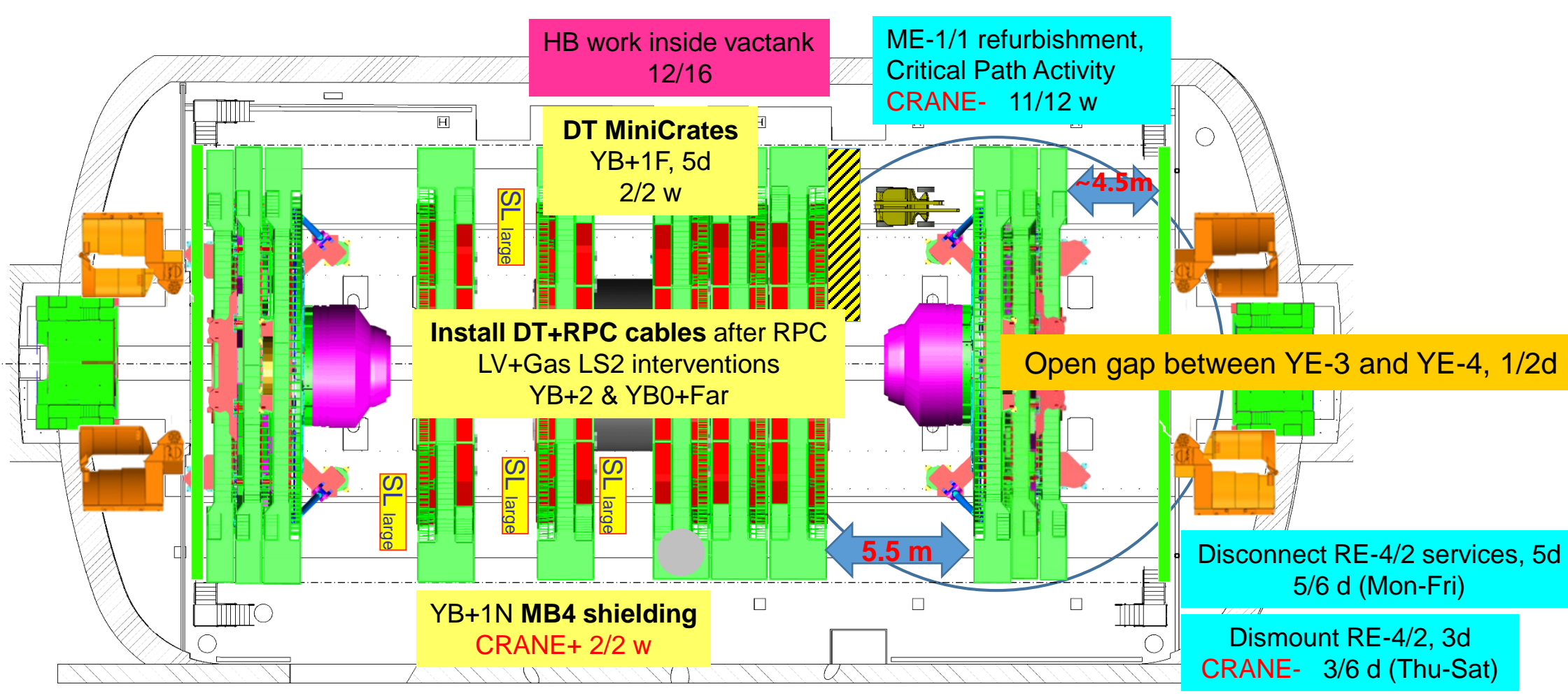
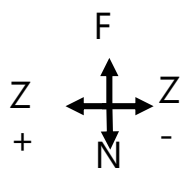

YE1 cable chain installation  
4/5W



Crane

Cryo.	█	EL power	█	Water cool.	█	Database	█								
IT	█	Magnet	█	C6F14	█	Gas	█								
SL.	0	GEM	█	ECAL	█	ZEC	█	DT+ RB	█	Survey	█	TE-VSC	█	GS Dept	█
CP.	0	TOTEM	█	CMX	█	CSC RE	█	TK PIX	█	HCAL	█	EN Dept	█	<b>RP</b>	█

PX56 Plug CLOSED	2019
TX54 Plug CLOSED	June – Week 23

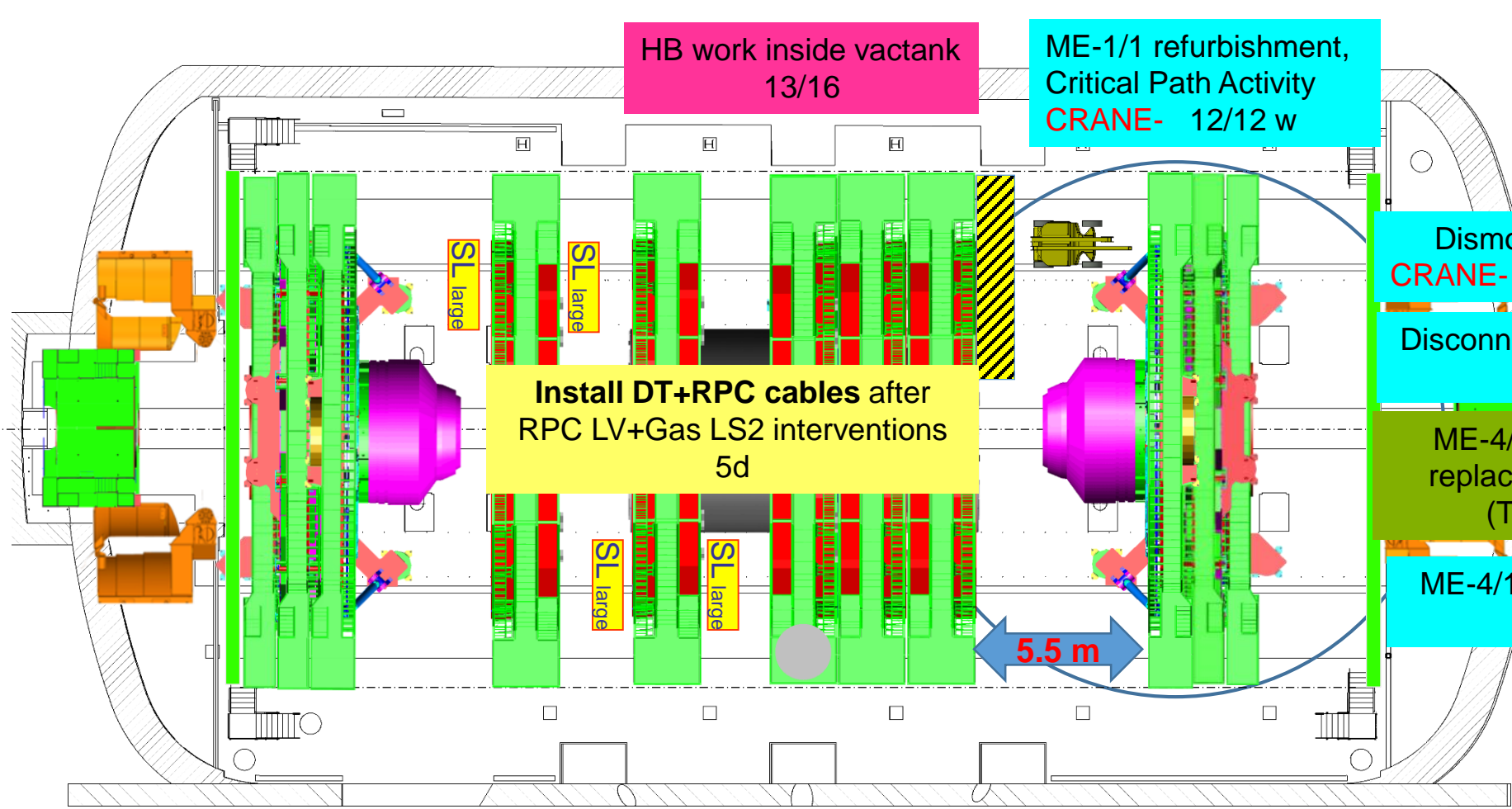
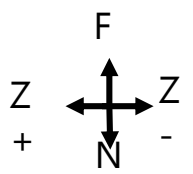





Crane

Cryo.	<span style="background-color: green; color: green;">█</span>	EL power	<span style="background-color: green; color: green;">█</span>	Water cool.	<span style="background-color: green; color: green;">█</span>	Database	<span style="background-color: green; color: green;">█</span>
IT	<span style="background-color: green; color: green;">█</span>	Magnet	<span style="background-color: red; color: red;">█</span>	C6F14	<span style="background-color: green; color: green;">█</span>	Gas	<span style="background-color: green; color: green;">█</span>
SL. 0	GEM	ECAL	ZEC	DT+ RB	Survey	TE-VSC	GS Dept
CP. 0	TOTEM	CMX	CSC RE	TK PIX	HCAL	EN Dept	<b>RP</b>

PX56 Plug CLOSED
TX54 Plug CLOSED

2019

June – Week 24

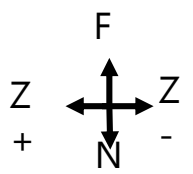

Disconnect Front ME+2/1 services, 1d (Thu) 1/1 d

Dismount 9 Front ME+2/1, 1d CRANE+ 1/2 d

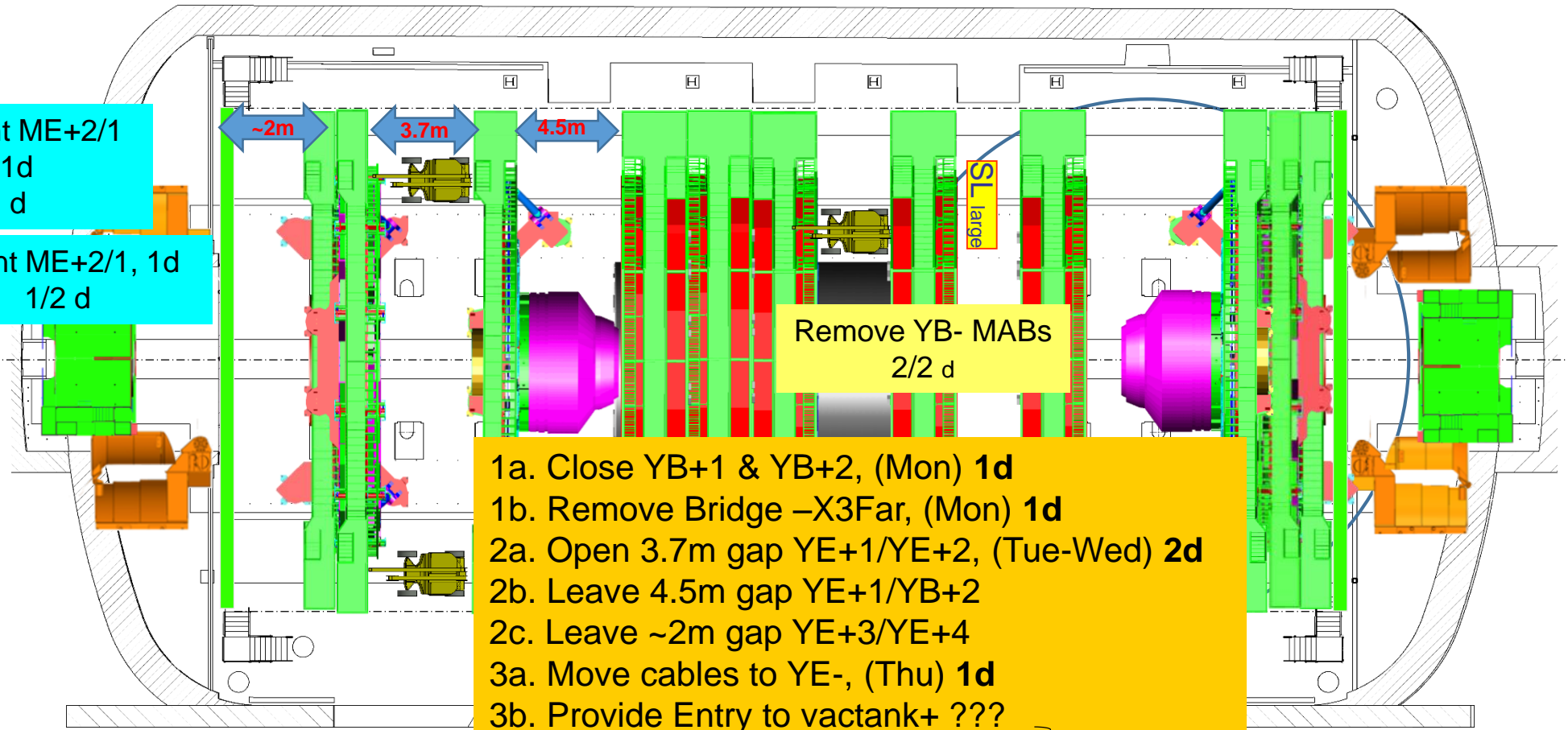

Remove YB- MABs  
2/2 d

- 1a. Close YB+1 & YB+2, (Mon) 1d
- 1b. Remove Bridge -X3Far, (Mon) 1d
- 2a. Open 3.7m gap YE+1/YE+2, (Tue-Wed) 2d
- 2b. Leave 4.5m gap YE+1/YB+2
- 2c. Leave ~2m gap YE+3/YE+4
- 3a. Move cables to YE-, (Thu) 1d
- 3b. Provide Entry to vactank+ ???
- 4. Close YE-, 2d
- 5. Open YB-2 & YB-1, 1d

2d in W25

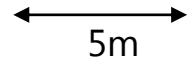

Test new YE+ cable chains?



Crane

Cryo.	<span style="background-color: green; color: green;">■</span>	EL power	<span style="background-color: green; color: green;">■</span>	Water cool.	<span style="background-color: green; color: green;">■</span>	Database	<span style="background-color: green; color: green;">■</span>
IT	<span style="background-color: green; color: green;">■</span>	Magnet	<span style="background-color: red; color: red;">■</span>	C6F14	<span style="background-color: green; color: green;">■</span>	Gas	<span style="background-color: green; color: green;">■</span>
SL. 0	GEM	ECAL	ZEC	DT+ RB	Survey	TE-VSC	GS Dept
CP. 0	TOTEM	CMX	CSC RE	TK PIX	HCAL	EN Dept	<b>RP</b>

PX56 Plug CLOSED

2019

TX54 Plug CLOSED

June – Week 25

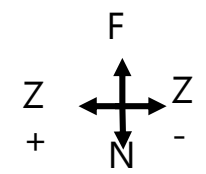

- Dismount 9 Front ME+2/1, 1d  
CRANE+ 2/2 d
- Disconnect Back ME+2/1 services, 2d
- Dismount 9 Back ME+2/1, 2d  
CRANE+ 2/2 d

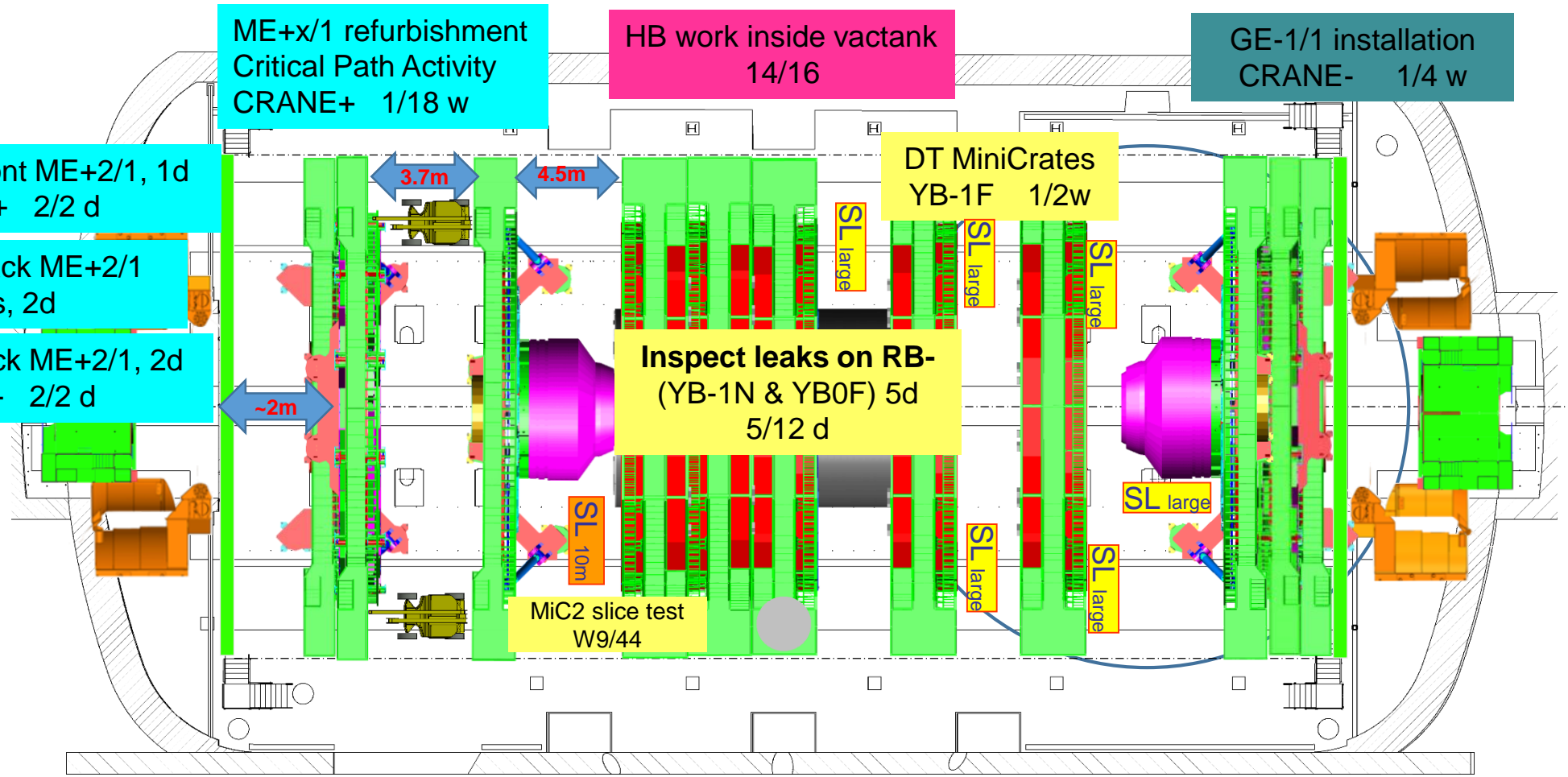

5m



Crane

Cryo.	<span style="background-color: green; color: green;">█</span>	EL power	<span style="background-color: green; color: green;">█</span>	Water cool.	<span style="background-color: green; color: green;">█</span>	Database	<span style="background-color: green; color: green;">█</span>
IT	<span style="background-color: green; color: green;">█</span>	Magnet	<span style="background-color: red; color: red;">█</span>	C6F14	<span style="background-color: green; color: green;">█</span>	Gas	<span style="background-color: green; color: green;">█</span>
SL. 0	GEM	ECAL	ZEC	DT+ RB	Survey	TE-VSC	GS Dept
CP. 0	TOTEM	CMX	CSC RE	TK PIX	HCAL	EN Dept	<b>RP</b>

PX56 Plug CLOSED
TX54 Plug CLOSED

2019
June – Week 26

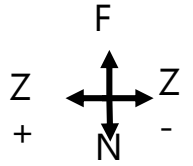

Move YE+2 disk towards YE1  
Leave 3.7m gap YE+2/YE+3  
1/2 d (Mon)

Disconnect 9 Front ME+3/1  
services, 1d  
(Tue) 1/1 d

Dismount 9 Front ME+3/1, 2d  
CRANE+ (Wed-Thu) 2/2 d

Disconnect 9 Back ME+3/1  
services, 1d  
(Fri) 2/2 d

ME+x/1 refurbishment  
Critical Path Activity  
CRANE+ 2/18 w

HB work inside vactank  
15/16

GE-1/1 installation  
CRANE- 2/4 w

DT MiniCrates  
YB0-F 1/1 w

Inspect leaks on RB-  
(YB-1F & YB0N) 4d  
(YB-2N) 1d  
10/12 d

MiC2 slice test  
W10/44

Phase 2 opening system installation Z+ NEAR  
4/5d

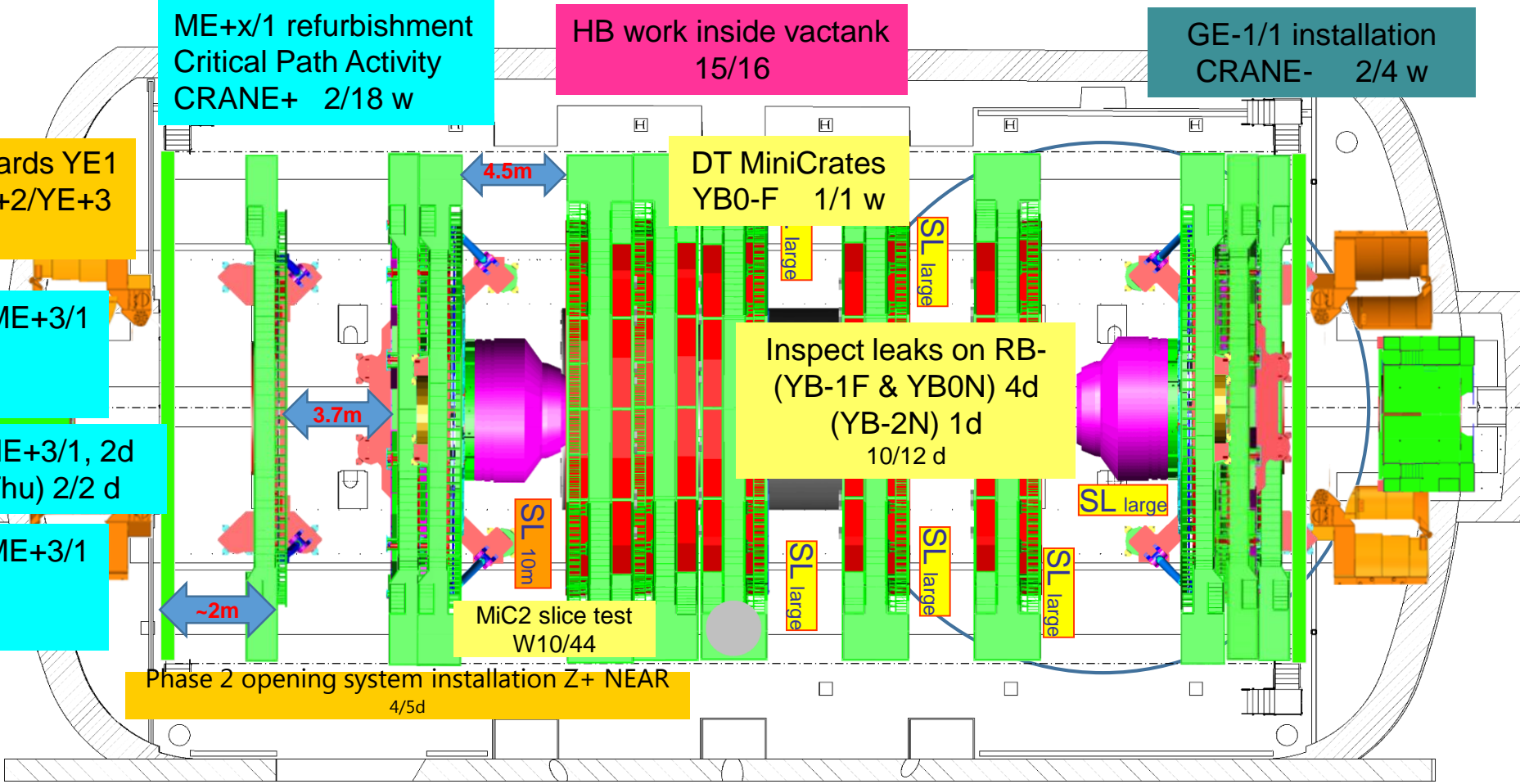

5m



Crane

Cryo.	<span style="background-color: green; color: green;">■</span>	EL power	<span style="background-color: green; color: green;">■</span>	Water cool.	<span style="background-color: green; color: green;">■</span>	Database	<span style="background-color: green; color: green;">■</span>
IT	<span style="background-color: green; color: green;">■</span>	Magnet	<span style="background-color: red; color: red;">■</span>	C6F14	<span style="background-color: green; color: green;">■</span>	Gas	<span style="background-color: green; color: green;">■</span>
SL. 0	GEM	ECAL	ZEC	DT+ RB	Survey	TE-VSC	GS Dept
CP. 0	TOTEM	CMX	CSC RE	TK PIX	HCAL	EN Dept	<b>RP</b>

PX56 Plug CLOSED

2019

TX54 Plug CLOSED

July – Week 27

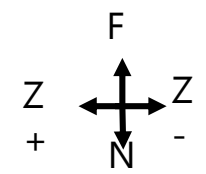

Disconnect 9 Back ME+3/1 services, 1d (Mon) 2/2 d

Dismount 9 Back ME+3/1, 2d CRANE+ (Tue-Wed) 2/2 d

Disconnect Front ME+4/1 services, 2d (Tue-Wed) 2/2 d

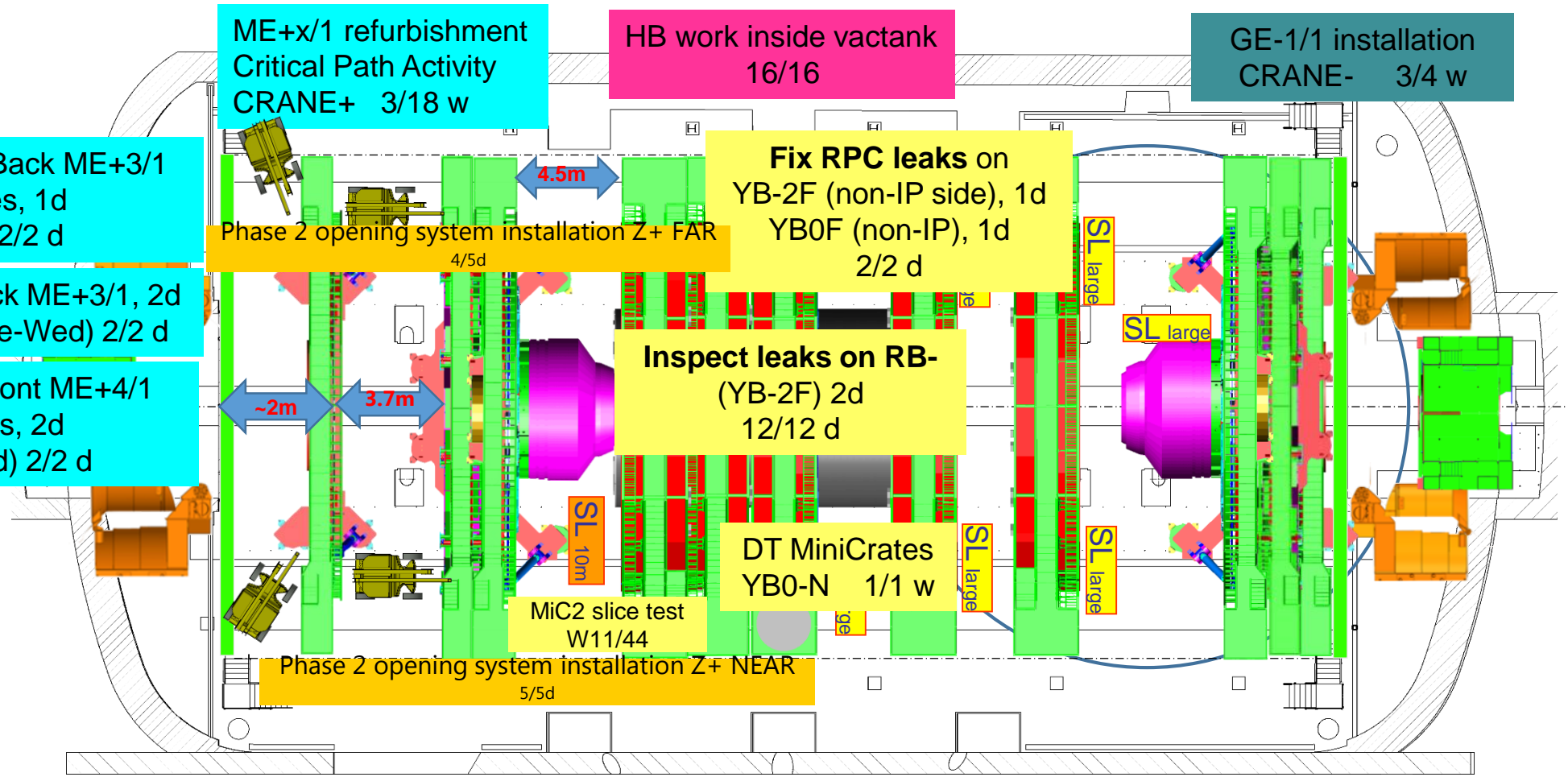

Remove DT+RPC cables for RPC LV+Gas LS2 interventions in YB-1 1/2 w

5m





Crane

Cryo.	<span style="background-color: green; color: green;">■</span>	EL power	<span style="background-color: green; color: green;">■</span>	Water cool.	<span style="background-color: green; color: green;">■</span>	Database	<span style="background-color: green; color: green;">■</span>
IT	<span style="background-color: green; color: green;">■</span>	Magnet	<span style="background-color: red; color: red;">■</span>	C6F14	<span style="background-color: green; color: green;">■</span>	Gas	<span style="background-color: green; color: green;">■</span>
SL. 0	GEM	ECAL	ZEC	DT+ RB	Survey	TE-VSC	GS Dept
CP. 0	TOTEM	CMX	CSC RE	TK PIX	HCAL	EN Dept	<b>RP</b>

PX56 Plug  
CLOSED

2019

TX54 Plug  
CLOSED

July – Week 28

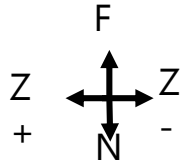

ME+x/1 refurbishment  
Critical Path Activity  
CRANE+ 4/18 w

GE-1/1 installation  
CRANE- 4/4 w

1. Move YE+3 disk towards YE2  
Leave ~5m gap YE+3/YE+4  
Leave ~1m gap YE+2/YE+3  
(Thu) 1 d

Phase 2 opening system installation Z+ FAR  
(Mon) 5/5d

DT MiniCrates  
YB-1F 2/2 w

Dismount 9 Front ME+4/1, 1d  
CRANE+ (Tue-Wed) 2/2 d

Fix RPC leaks on YB-1N  
(IP side), 5d  
5/5 d

Disconnect 9 Back ME+4/1  
services, 2d  
(Wed-Thu) 2/2 d

Dismount 9 Back ME+4/1, 1d  
CRANE+ (Fri) 1/2 d

MiC2 slice test  
W12/44

Remove DT+RPC cables for RPC  
LV+Gas LS2 interventions in YB-2  
2/2 w

5m



Crane

Cryo.	<span style="background-color: green; color: green;">█</span>	EL power	<span style="background-color: green; color: green;">█</span>	Water cool.	<span style="background-color: green; color: green;">█</span>	Database	<span style="background-color: green; color: green;">█</span>	
IT	<span style="background-color: green; color: green;">█</span>	Magnet	<span style="background-color: red; color: red;">█</span>	C6F14	<span style="background-color: green; color: green;">█</span>	Gas	<span style="background-color: green; color: green;">█</span>	
SL.	0	GEM	ECAL	ZEC	DT+ RB	Survey	TE-VSC	GS Dept
CP.	0	TOTEM	CMX	CSC RE	TK PIX	HCAL	EN Dept	<b>RP</b>

PX56 Plug CLOSED

2019

TX54 Plug CLOSED

July – Week 29

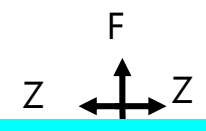

Dismount 9 Back ME+4/1, 1d  
CRANE+ (Mon) 2/2 d

1. Move YE+3 disk towards YE4
  2. Move YE+2 disk towards YE3
- Leave 3.7m gap YE+1/YE+2  
Leave ~2.3m gap YE+3/YE+4  
(Tue) 1 d

Install 9 BACK ME+2/1, 2d  
CRANE+ (Wed-Thu) 2/2 d

Cabling & Connectivity  
9 BACK ME+2/1, 1d  
(Fri) 1/4 d

Install RE+4/1 gas services, 5d  
ZEC, 5/10 d

ME+x/1 refurbishment  
Critical Path Activity  
CRANE+ 5/18 w

GE-1/1 service installation  
1/7 week

GE-1/1 gas service installation, 5d  
ZEC 1/2 w

Fix RPC leaks on YB-1F  
(IP side), 5d  
5/10 d

YE+1 Change 4 airpads (375t)  
(Thu-Fri) 2/4d

DT MiniCrates  
YB-1N 1/2 w

MiC2 slice test  
W13/44

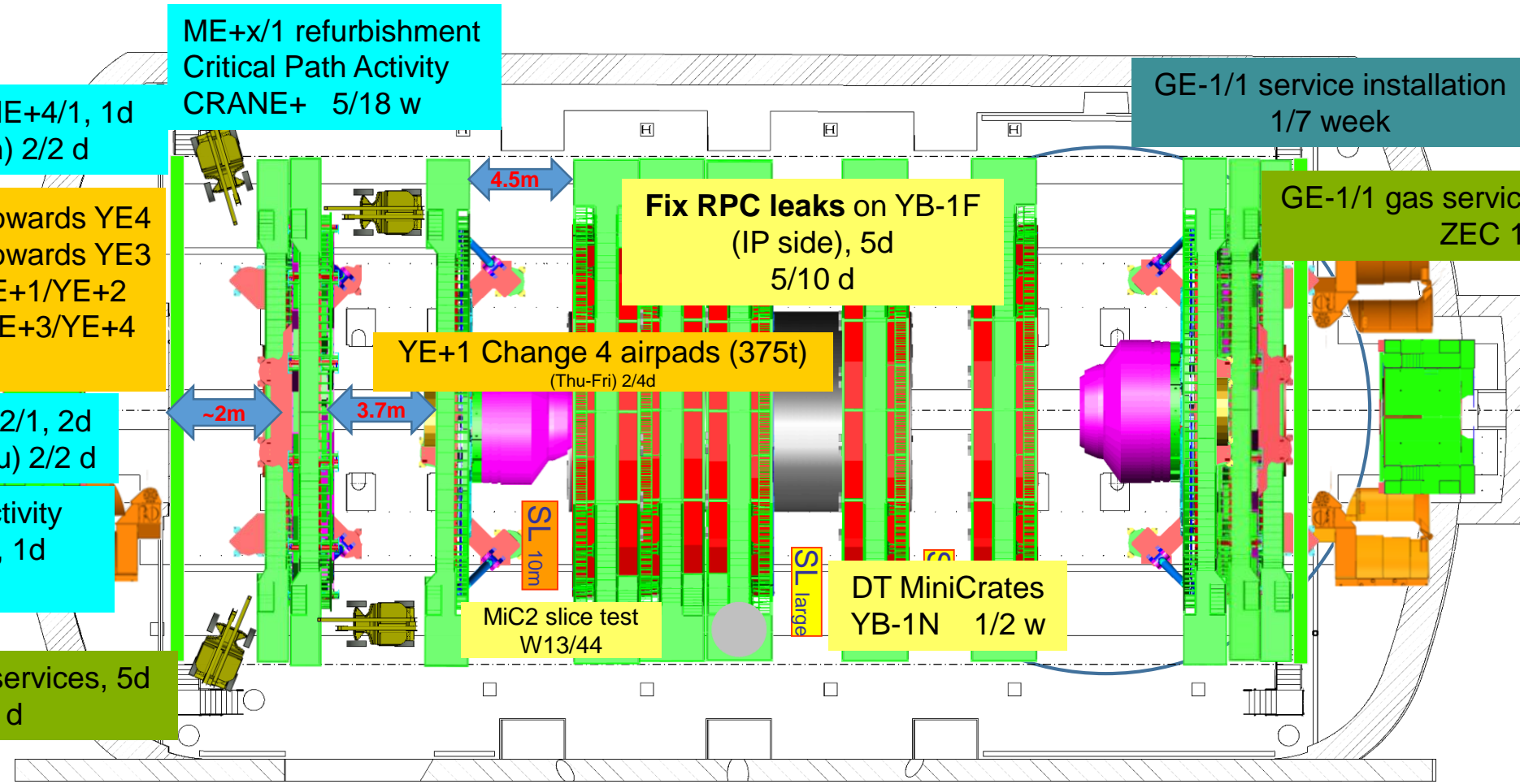



Crane

Cryo.	<span style="background-color: green; color: green;">█</span>	EL power	<span style="background-color: green; color: green;">█</span>	Water cool.	<span style="background-color: green; color: green;">█</span>	Database	<span style="background-color: green; color: green;">█</span>
IT	<span style="background-color: green; color: green;">█</span>	Magnet	<span style="background-color: red; color: red;">█</span>	C6F14	<span style="background-color: green; color: green;">█</span>	Gas	<span style="background-color: green; color: green;">█</span>
SL. 0	<span style="background-color: teal; color: white;">GEM</span>	<span style="background-color: purple; color: white;">ECAL</span>	<span style="background-color: olive; color: white;">ZEC</span>	<span style="background-color: yellow; color: black;">DT+ RB</span>	<span style="background-color: grey; color: white;">Survey</span>	<span style="background-color: pink; color: black;">TE-VSC</span>	<span style="background-color: brown; color: white;">GS Dept</span>
CP. 0	<span style="background-color: olive; color: white;">TOTEM</span>	<span style="background-color: yellow; color: black;">CMX</span>	<span style="background-color: cyan; color: black;">CSC RE</span>	<span style="background-color: maroon; color: white;">TK PIX</span>	<span style="background-color: magenta; color: black;">HCAL</span>	<span style="background-color: orange; color: black;">EN Dept</span>	<span style="border: 2px solid black; padding: 2px;"><b>RP</b></span>

PX56 Plug  
CLOSED

TX54 Plug  
CLOSED

2019

July – Week 30

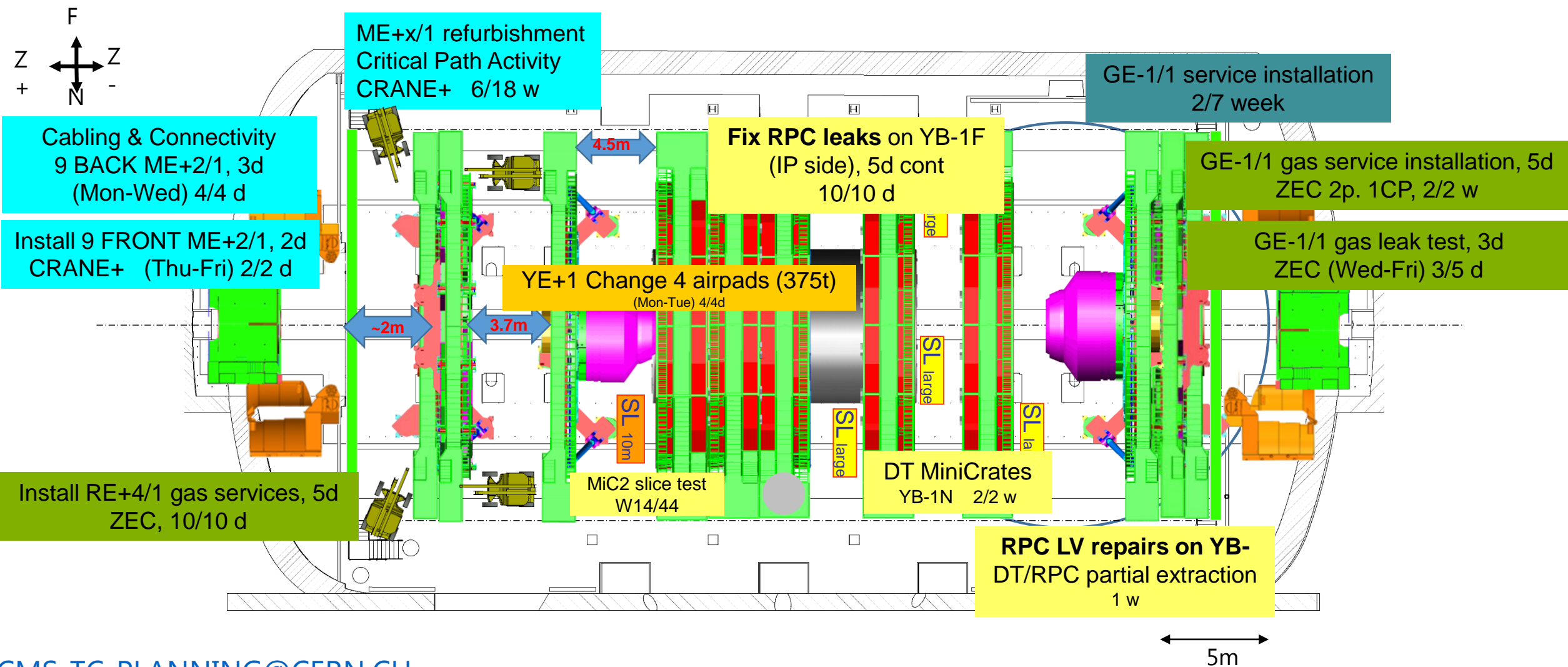



Cryo.	█	EL power	█	Water cool.	█	Database	█
IT	█	Magnet	█	C6F14	█	Gas	█
SL. 0	GEM	ECAL	ZEC	DT+ RB	Survey	TE-VSC	GS Dept
CP. 0	TOTEM	CMX	CSC RE	TK PIX	HCAL	EN Dept	<b>RP</b>

PX56 Plug  
CLOSED

TX54 Plug  
CLOSED

2019

July – Week 31

Crane

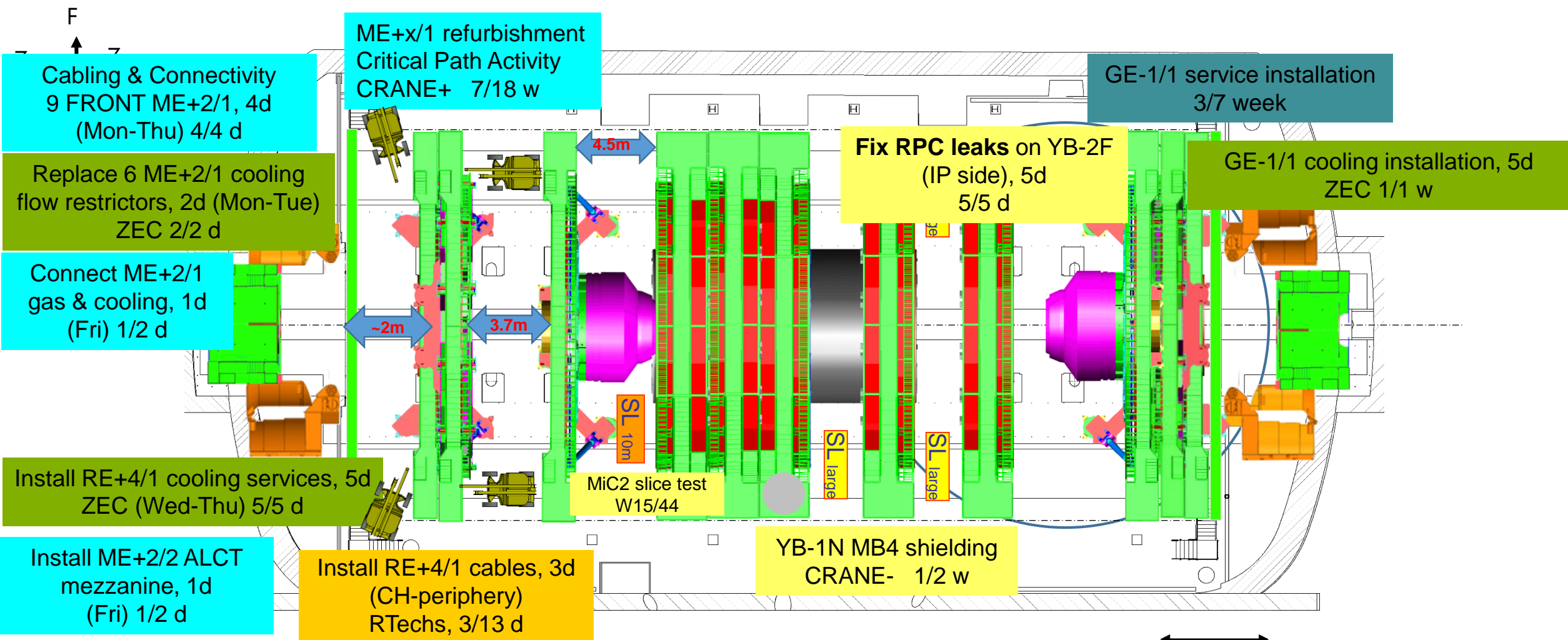





Crane

Cryo.	█	EL power	█	Water cool.	█	Database	█
IT	█	Magnet	█	C6F14	█	Gas	█
SL. 0	GEM	ECAL	ZEC	DT+ RB	Survey	TE-VSC	GS Dept
CP. 0	TOTEM	CMX	CSC RE	TK PIX	HCAL	EN Dept	<b>RP</b>

PX56 Plug  
CLOSED

2019

TX54 Plug  
CLOSED

August – Week 32

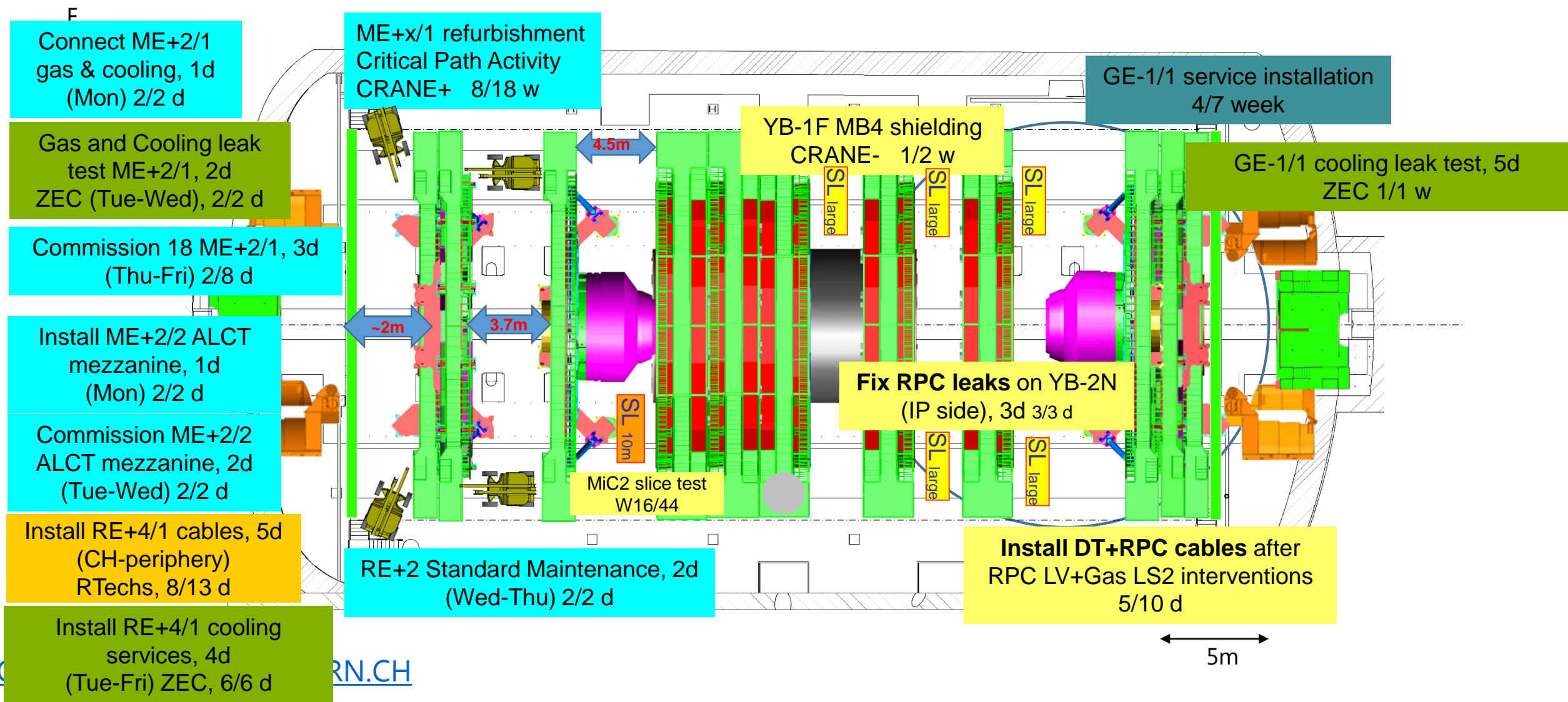





Crane

Cryo.	<span style="color: green;">■</span>	EL power	<span style="color: green;">■</span>	Water cool.	<span style="color: green;">■</span>	Database	<span style="color: green;">■</span>
IT	<span style="color: green;">■</span>	Magnet	<span style="color: red;">■</span>	C6F14	<span style="color: green;">■</span>	Gas	<span style="color: green;">■</span>
SL. 0	GEM	ECAL	ZEC	DT+ RB	Survey	TE-VSC	GS Dept
CP. 0	TOTEM	CMX	CSC RE	TK PIX	HCAL	EN Dept	<b>RP</b>

PX56 Plug  
CLOSED

2019

TX54 Plug  
CLOSED

August – Week 33

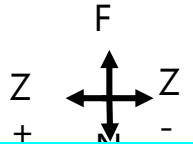

Commission 18 ME+2/1, 2d  
(Mon-Tue) 4/8 d

1. Move YE2 disk towards YE+1
  2. Move YE3 disk towards YE+2
- Leave 4m gap YE+3/YE+4  
Leave ~1.9m gap YE+1/YE+2  
(Wed) 1 d

Install 9 BACK ME+4/1, 2d  
CRANE+ (Thu-Fri) 2/2 d

Commission 18 ME+2/1 in  
smaller gap, 3d  
(Wed-Fri) 7/8 d

ME+x/1 refurbishment  
Critical Path Activity  
CRANE+ 9/18 w

4.5m

YB-1F MB4 shielding  
CRANE- 2/2 w

GE-1/1 service installation  
5/7 week

GE-1/1 gas leak test, 2d  
ZEC (Mon-Tue) 5/5 d

GE-1/1 cable installation, 5d  
RTechs 1/2 w

SL 10m

MiC2 slice test  
W17/44

4m

5m



Crane

Cryo.	<span style="background-color: green; color: green;">■</span>	EL power	<span style="background-color: green; color: green;">■</span>	Water cool.	<span style="background-color: green; color: green;">■</span>	Database	<span style="background-color: green; color: green;">■</span>
IT	<span style="background-color: green; color: green;">■</span>	Magnet	<span style="background-color: red; color: red;">■</span>	C6F14	<span style="background-color: green; color: green;">■</span>	Gas	<span style="background-color: green; color: green;">■</span>
SL. 0	GEM	ECAL	ZEC	DT+ RB	Survey	TE-VSC	GS Dept
CP. 0	TOTEM	CMX	CSC RE	TK PIX	HCAL	EN Dept	<b>RP</b>

PX56 Plug  
CLOSED

2019

TX54 Plug  
CLOSED

August – Week 34

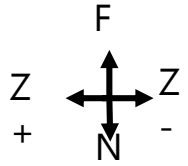

ME+x/1 refurbishment  
Critical Path Activity  
CRANE+ 10/18 w

GE-1/1 service installation  
6/7 week

Commission 18 ME+2/1 in  
smaller gap, 1d  
(Mon) 8/8 d

Cabling & Connectivity  
9 BACK ME+4/1, 4d  
(Mon-Thu) 4/4 d

Install 9 FRONT ME+4/1, 1d  
CRANE+ (Fri) 1/2 d

GE-1/1 cable installation, 5d  
RTechs 2/2 w

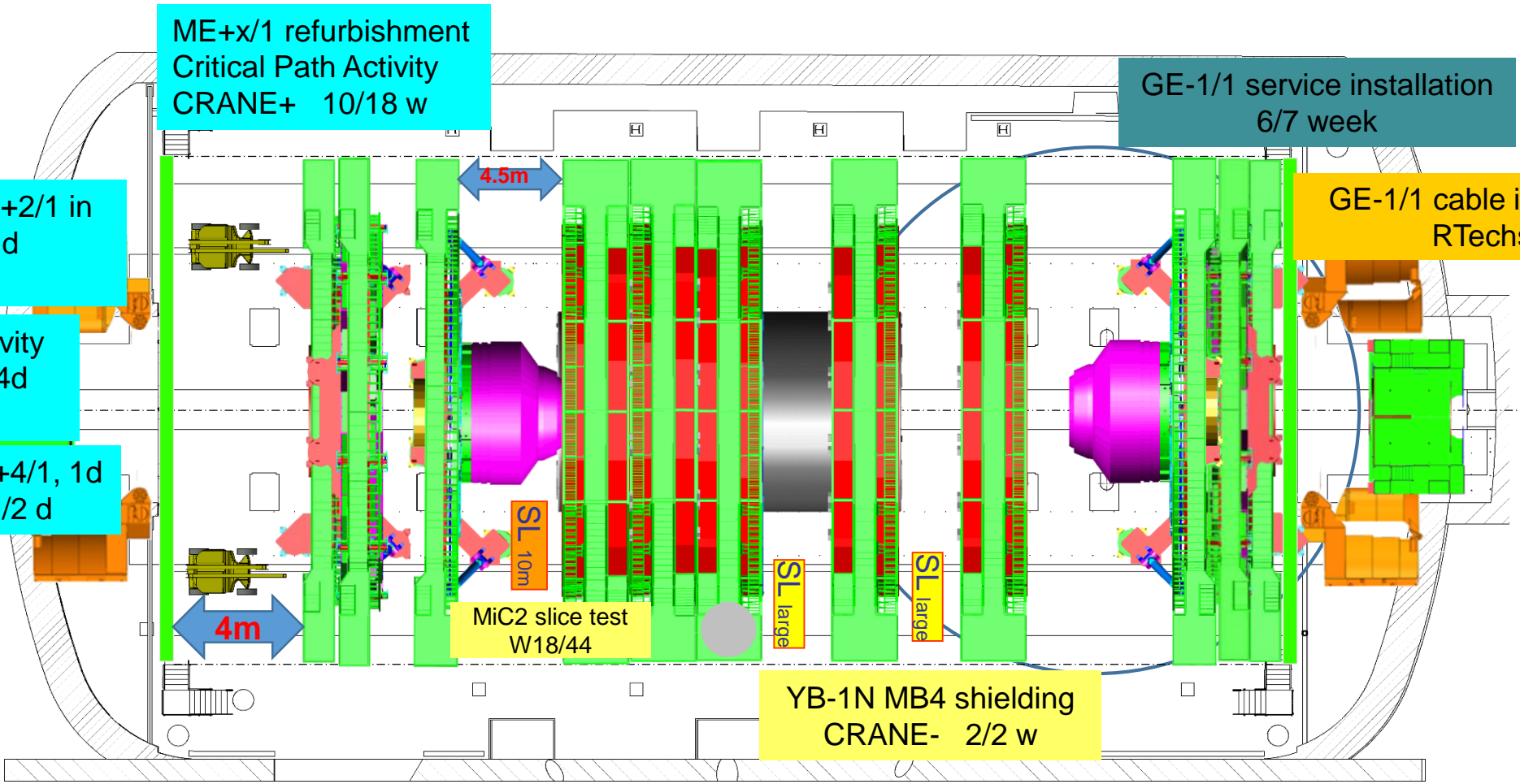

YB-1N MB4 shielding  
CRANE- 2/2 w

5m



Crane

Cryo.	<span style="background-color: green; color: green;">█</span>	EL power	<span style="background-color: green; color: green;">█</span>	Water cool.	<span style="background-color: green; color: green;">█</span>	Database	<span style="background-color: green; color: green;">█</span>
IT	<span style="background-color: green; color: green;">█</span>	Magnet	<span style="background-color: red; color: red;">█</span>	C6F14	<span style="background-color: green; color: green;">█</span>	Gas	<span style="background-color: green; color: green;">█</span>
SL. 0	GEM	ECAL	ZEC	DT+ RB	Survey	TE-VSC	GS Dept
CP. 0	TOTEM	CMX	CSC RE	TK PIX	HCAL	EN Dept	<b>RP</b>

PX56 Plug  
CLOSED

TX54 Plug  
CLOSED

2019

August – Week 35

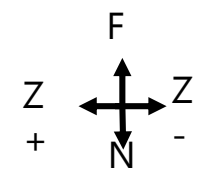

- Install 9 FRONT ME+4/1, 1d  
CRANE+ (Mon) 2/2 d
- Cabling & Connectivity  
9 FRONT ME+4/1, 3d  
(Tue-Thu) 3/3 d
- Connect ME+4/1  
gas & cooling, 1d  
(Fri) 1/2 d
- Replace 6 ME+4/1 cooling  
flow restrictors, 2d (Wed-Thu)  
ZEC 2/2 d

ME+x/1 refurbishment  
Critical Path Activity  
CRANE+ 11/18 w

GE-1/1 service installation  
7/7 week

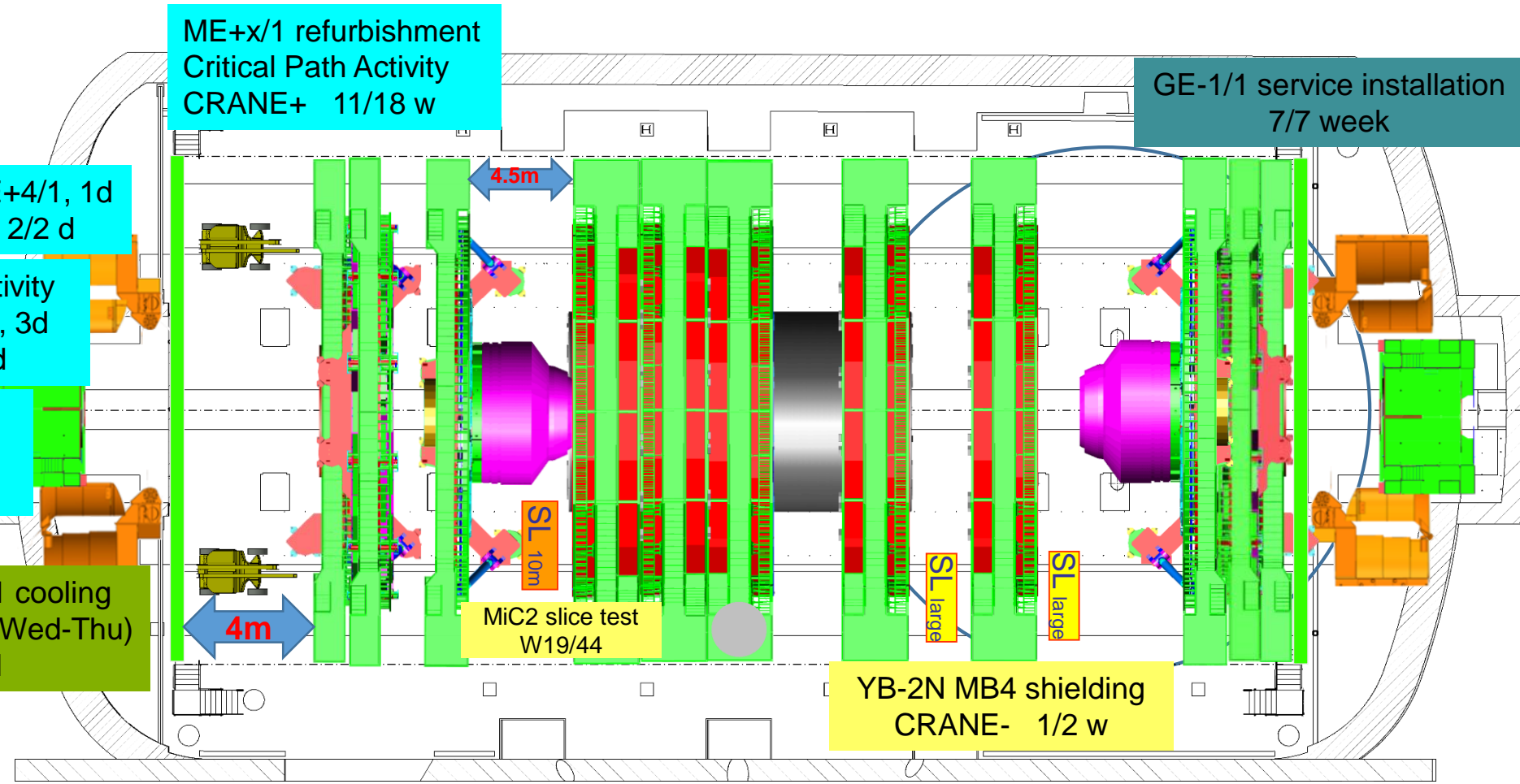

5m



Crane

Cryo.	█	EL power	█	Water cool.	█	Database	█								
IT	█	Magnet	█	C6F14	█	Gas	█								
SL.	0	GEM	█	ECAL	█	ZEC	█	DT+ RB	█	Survey	█	TE-VSC	█	GS Dept	█
CP.	0	TOTEM	█	CMX	█	CSC RE	█	TK PIX	█	HCAL	█	EN Dept	█	<b>RP</b>	█

PX56 Plug  
CLOSED

TX54 Plug  
CLOSED

2019

September – Week 36

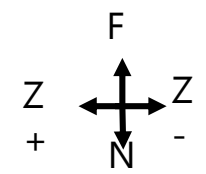

Connect ME+4/1  
gas & cooling, 1d  
(Mon) 2/2 d

Gas and Cooling leak  
test ME+4/1, 2d  
ZEC (Tue-Wed) 2/2 d

Commission 18 ME+4/1, 2d  
(Thu-Fri) 2/8 d

ME+x/1 refurbishment  
Critical Path Activity  
CRANE+ 12/18 w

HB work inside vactank  
1/16

GE-1/1 commissioning  
1/6 week

Jeune Genevois

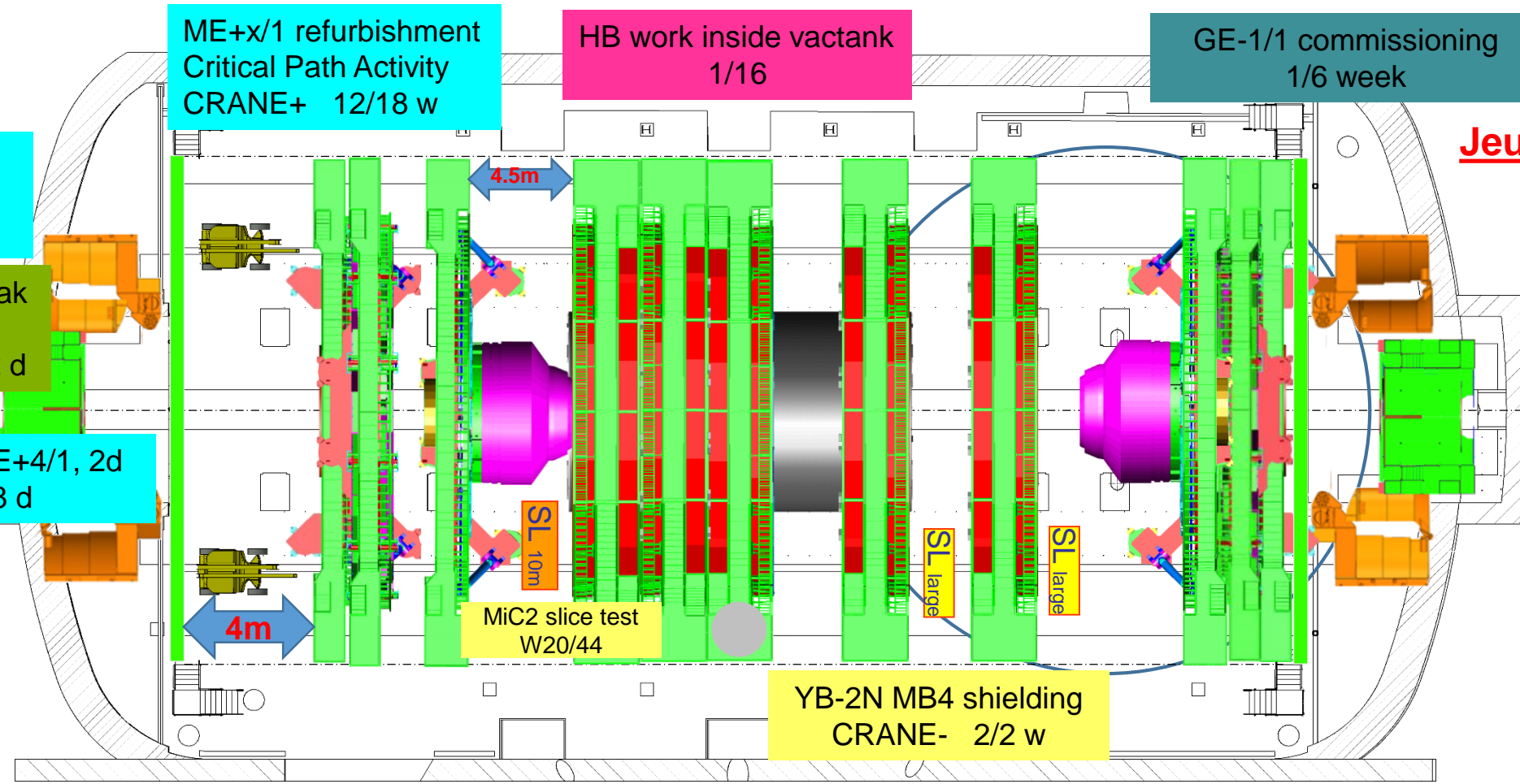





Cryo.	<span style="background-color: green; color: green;">■</span>	EL power	<span style="background-color: green; color: green;">■</span>	Water cool.	<span style="background-color: green; color: green;">■</span>	Database	<span style="background-color: green; color: green;">■</span>
IT	<span style="background-color: green; color: green;">■</span>	Magnet	<span style="background-color: red; color: red;">■</span>	C6F14	<span style="background-color: green; color: green;">■</span>	Gas	<span style="background-color: green; color: green;">■</span>
SL. 0	GEM	ECAL	ZEC	DT+ RB	Survey	TE-VSC	GS Dept
CP. 0	TOTEM	CMX	CSC RE	TK PIX	HCAL	EN Dept	<b>RP</b>

PX56 Plug  
CLOSED

TX54 Plug  
CLOSED

2019

September – Week 37

Crane

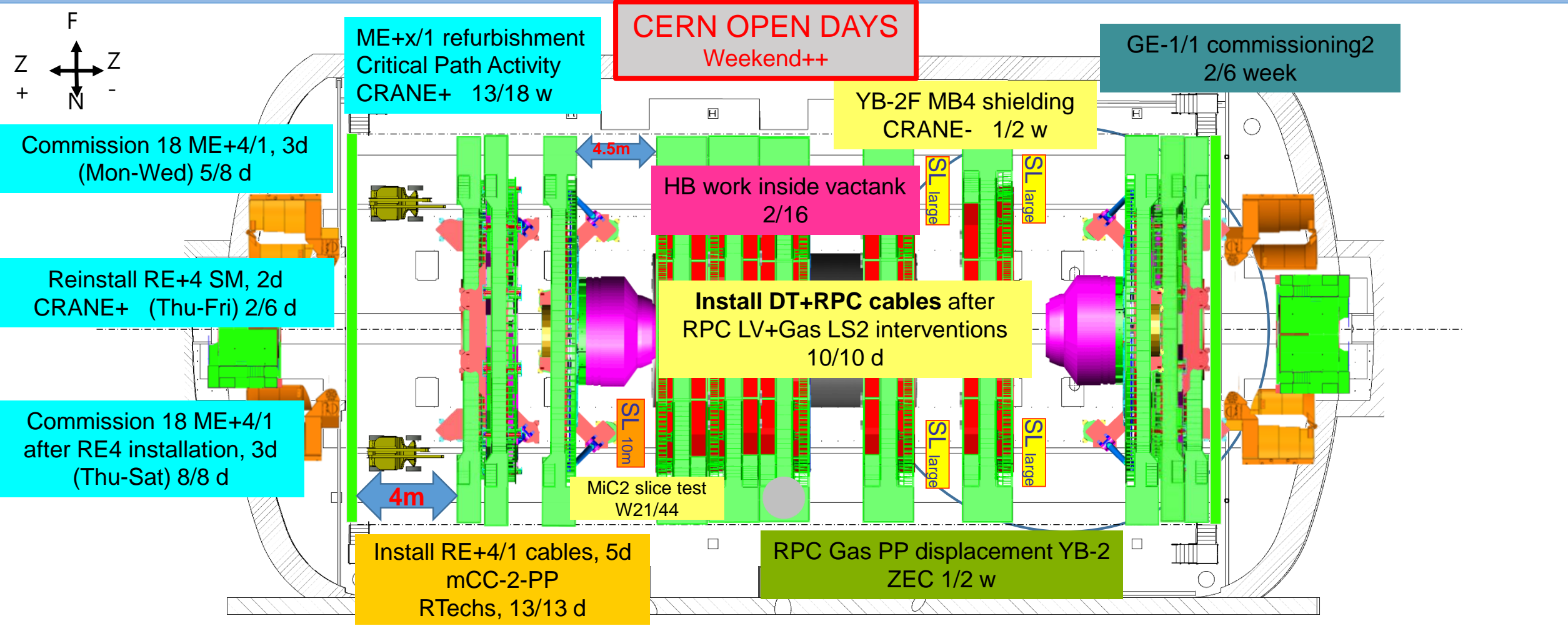





2019

September – Week 38

Cryo.	█	EL power	█	Water cool.	█	Database	█
IT	█	Magnet	█	C6F14	█	Gas	█
SL. 0	GEM	ECAL	ZEC	DT+ RB	Survey	TE-VSC	GS Dept
CP. 0	TOTEM	CMX	CSC RE	TK PIX	HCAL	EN Dept	<b>RP</b>

PX56 Plug  
CLOSED

TX54 Plug  
CLOSED

Crane

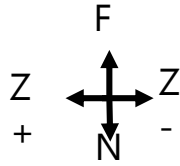

Reinstall RE+4 SM, 4d  
CRANE+ (Mon-Thu) 6/6 d

Cable RE+4 SM, 3d  
(Tue-Thu) 3/6 d

1. Move YE2 disk towards YE+1
  2. Move YE3 disk towards YE+4
- Leave 3.7m gap YE+2/YE+3  
Leave ~2m gap YE+3/YE+4  
(Fri) 1 d

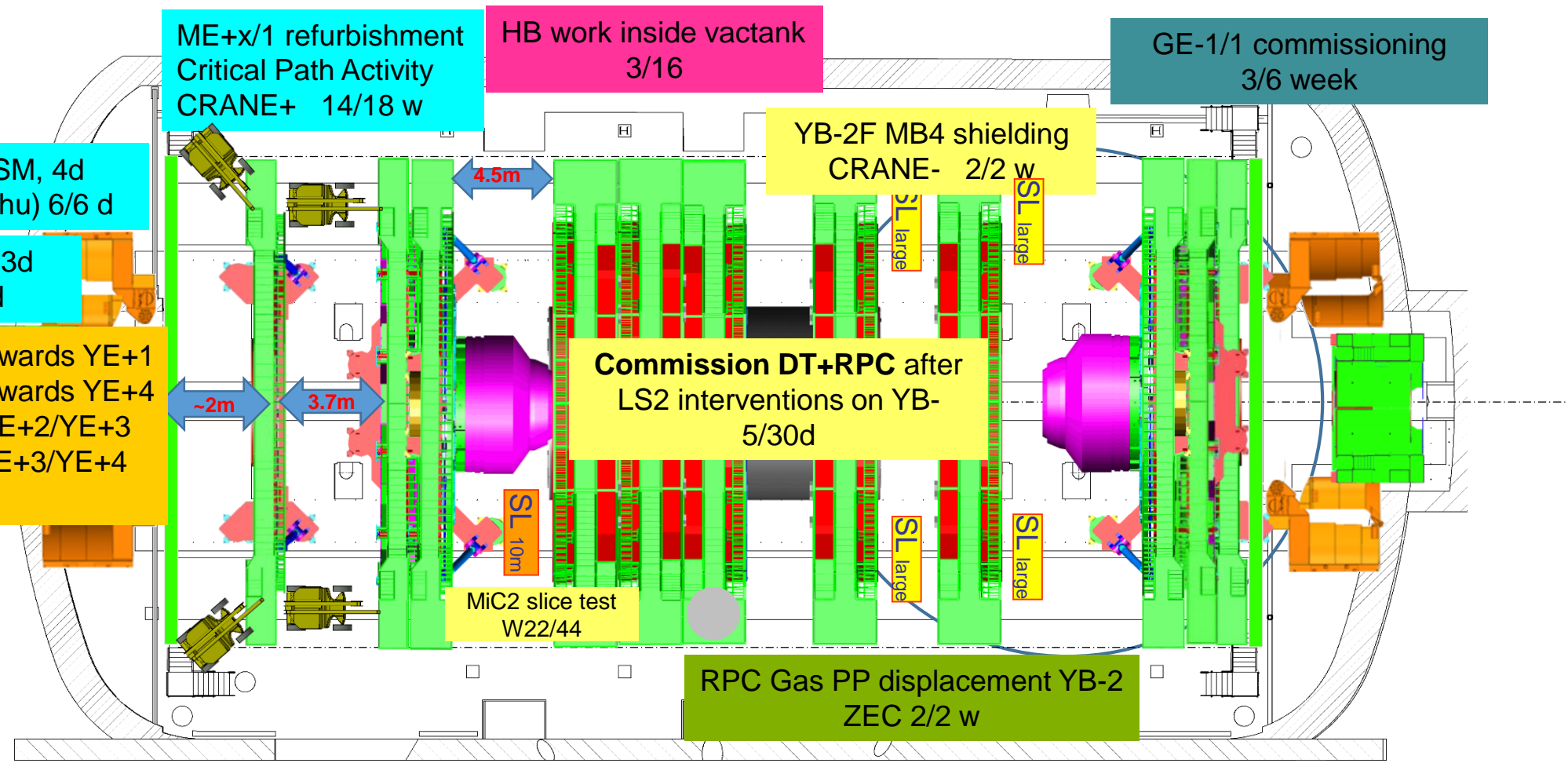

5m



Crane

Cryo.	<span style="background-color: green; color: white;">■</span>	EL power	<span style="background-color: green; color: white;">■</span>	Water cool.	<span style="background-color: green; color: white;">■</span>	Database	<span style="background-color: green; color: white;">■</span>								
IT	<span style="background-color: green; color: white;">■</span>	Magnet	<span style="background-color: red; color: white;">■</span>	C6F14	<span style="background-color: green; color: white;">■</span>	Gas	<span style="background-color: green; color: white;">■</span>								
SL.	0	GEM	<span style="background-color: blue; color: white;">■</span>	ECAL	<span style="background-color: purple; color: white;">■</span>	ZEC	<span style="background-color: green; color: white;">■</span>	DT+ RB	<span style="background-color: yellow; color: black;">■</span>	Survey	<span style="background-color: grey; color: white;">■</span>	TE-VSC	<span style="background-color: pink; color: black;">■</span>	GS Dept	<span style="background-color: brown; color: white;">■</span>
CP.	0	TOTEM	<span style="background-color: olive; color: white;">■</span>	CMX	<span style="background-color: yellow; color: black;">■</span>	CSC RE	<span style="background-color: cyan; color: black;">■</span>	TK PIX	<span style="background-color: purple; color: white;">■</span>	HCAL	<span style="background-color: magenta; color: black;">■</span>	EN Dept	<span style="background-color: orange; color: black;">■</span>	<b>RP</b>	<span style="background-color: white; border: 2px solid black; color: black;">■</span>

PX56 Plug  
CLOSED

2019

TX54 Plug  
CLOSED

September – Week 39

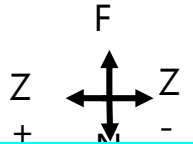

ME+x/1 refurbishment  
Critical Path Activity  
CRANE+ 15/18 w

HB work inside vactank  
4/16

GE-1/1 commissioning  
4/6 week

Install 9 BACK ME+3/1, 2d  
CRANE+ (Mon-Tue) 2/2 d

Cabling & Connectivity  
9 BACK ME+3/1, 3d  
(Wed-Fri) 3/4 d

Cable RE+4 SM, 3d  
(Mon-Wed) 6/6 d

Commission RE+4 SM, 2d  
(Thu-Fri) 2/8 d

Install ME+4/2 ALCT  
mezzanine, 2d  
(Wed-Thu) 2/2 d

Commission ME+4/2  
ALCT mezzanine, 1d  
(Fri) 1/2 d

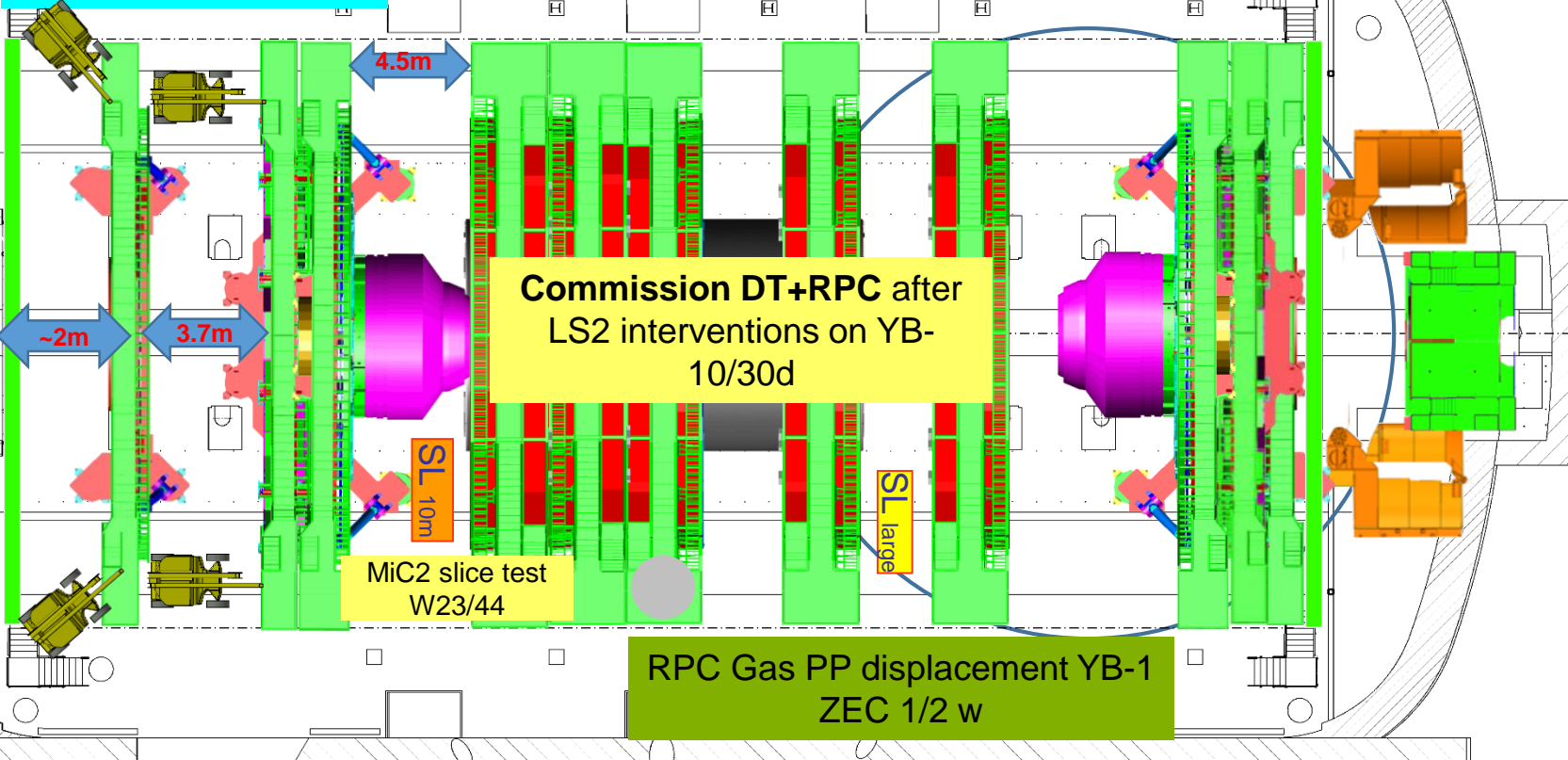

5m



Crane

Cryo.	<span style="background-color: green; color: green;">■</span>	EL power	<span style="background-color: green; color: green;">■</span>	Water cool.	<span style="background-color: green; color: green;">■</span>	Database	<span style="background-color: green; color: green;">■</span>
IT	<span style="background-color: green; color: green;">■</span>	Magnet	<span style="background-color: red; color: red;">■</span>	C6F14	<span style="background-color: green; color: green;">■</span>	Gas	<span style="background-color: green; color: green;">■</span>
SL. 0	GEM	ECAL	ZEC	DT+ RB	Survey	TE-VSC	GS Dept
CP. 0	TOTEM	CMX	CSC RE	TK PIX	HCAL	EN Dept	<b>RP</b>

PX56 Plug  
CLOSED

TX54 Plug  
CLOSED

2019

September – Week 40

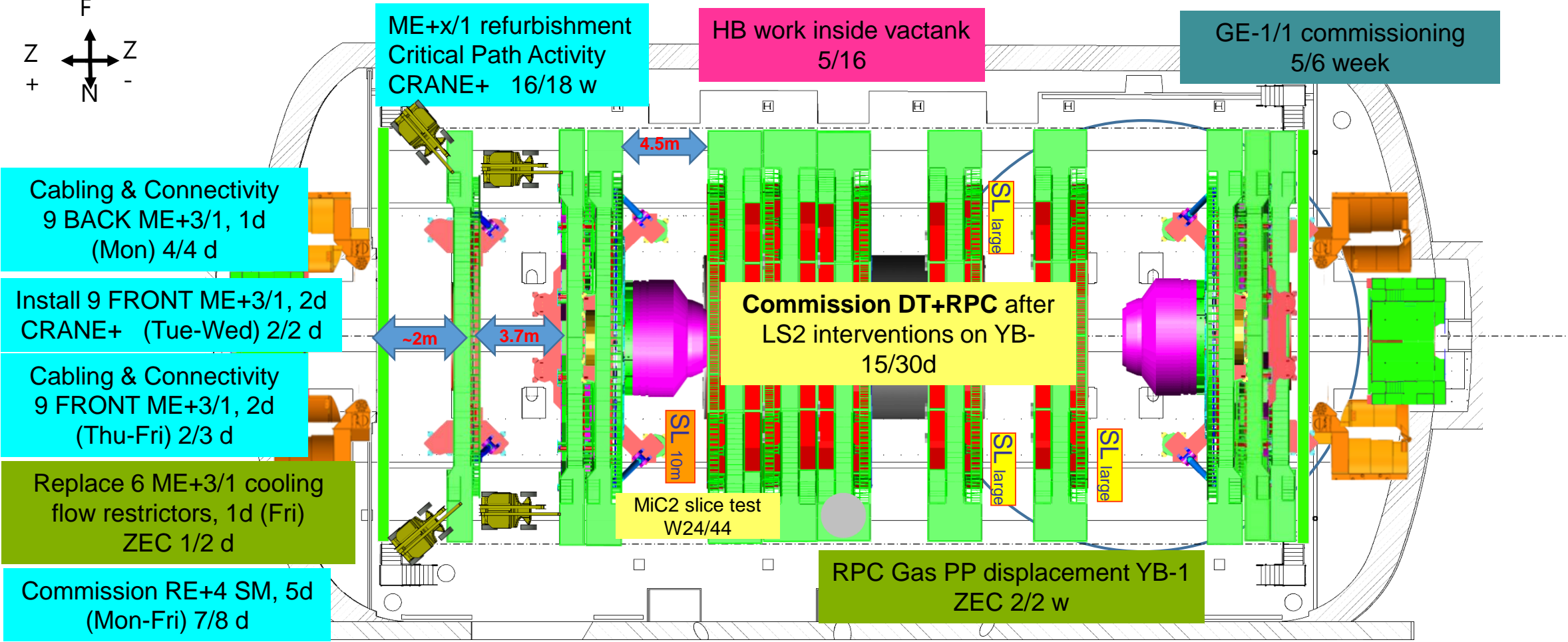
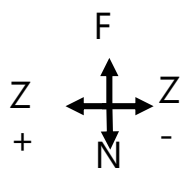

5m



Crane

Cryo.	<span style="color: green;">■</span>	EL power	<span style="color: green;">■</span>	Water cool.	<span style="color: green;">■</span>	Database	<span style="color: green;">■</span>
IT	<span style="color: green;">■</span>	Magnet	<span style="color: red;">■</span>	C6F14	<span style="color: green;">■</span>	Gas	<span style="color: green;">■</span>
SL. 0	GEM	ECAL	ZEC	DT+ RB	Survey	TE-VSC	GS Dept
CP. 0	TOTEM	CMX	CSC RE	TK PIX	HCAL	EN Dept	<b>RP</b>

PX56 Plug  
CLOSED

2019

TX54 Plug  
CLOSED

October – Week 41

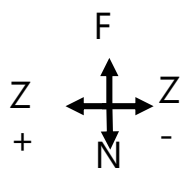

ME+x/1 refurbishment  
Critical Path Activity  
CRANE+ 17/18 w

HB work inside vactank  
6/16

GE-1/1 commissioning  
6/6 week

Replace 6 ME+3/1 cooling  
flow restrictors, 1d (Mon)  
ZEC 2/2 d

Cabling & Connectivity  
9 FRONT ME+3/1, 1d  
(Mon) 3/3 d

Connect ME+3/1  
gas & cooling, 2d  
(Tue-Wed) 2/2 d

Gas and Cooling leak  
test ME+3/1, 2d  
ZEC (Thu-Fri) 2/2 d

Install ME+3/2 ALCT  
mezzanine, 2d  
(Thu-Fri) 2/2 d

Commission RE+4 SM, 1d  
(Mon) 8/8 d

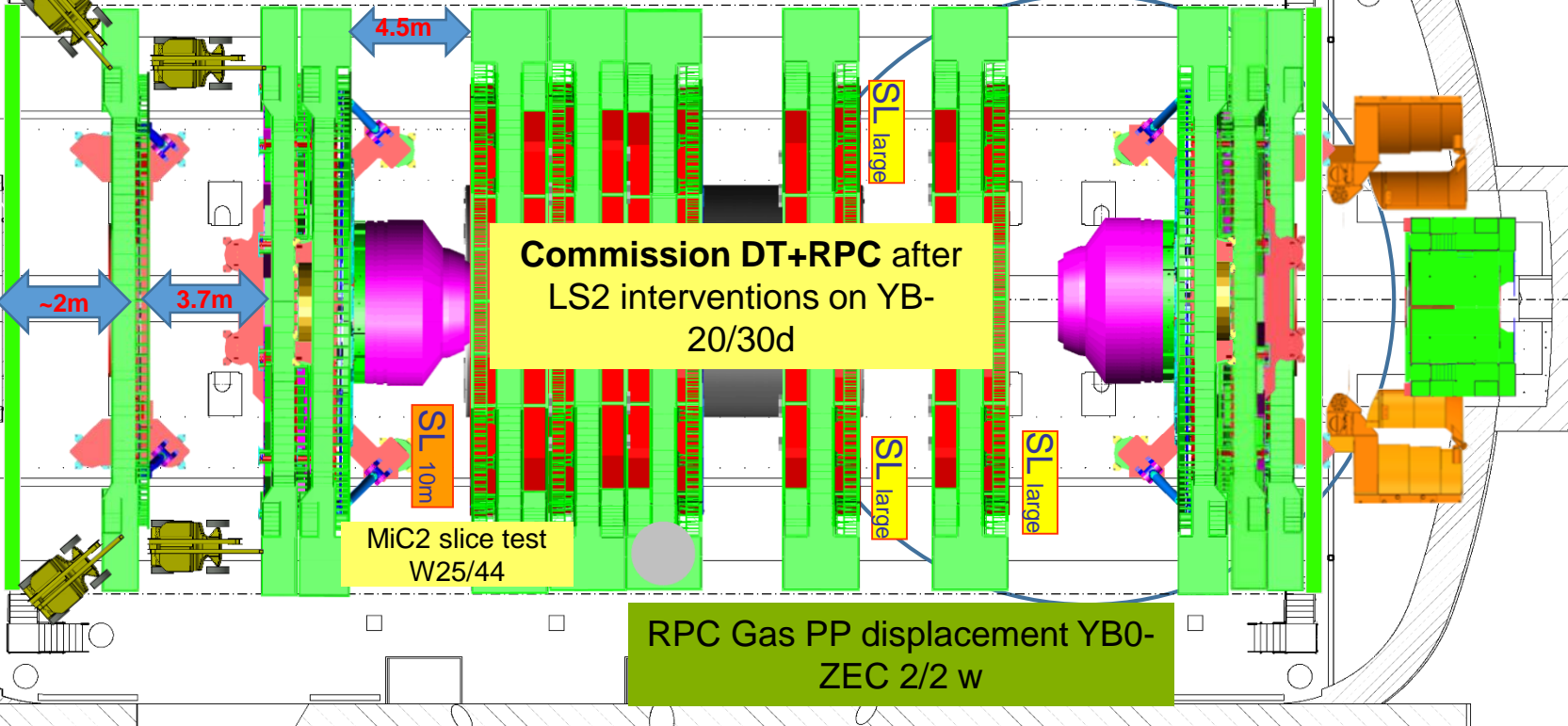

5m





Crane

Cryo.	█	EL power	█	Water cool.	█	Database	█
IT	█	Magnet	█	C6F14	█	Gas	█
SL. 0	GEM	ECAL	ZEC	DT+ RB	Survey	TE-VSC	GS Dept
CP. 0	TOTEM	CMX	CSC RE	TK PIX	HCAL	EN Dept	<b>RP</b>

PX56 Plug  
CLOSED

TX54 Plug  
CLOSED

2019

October – Week 42

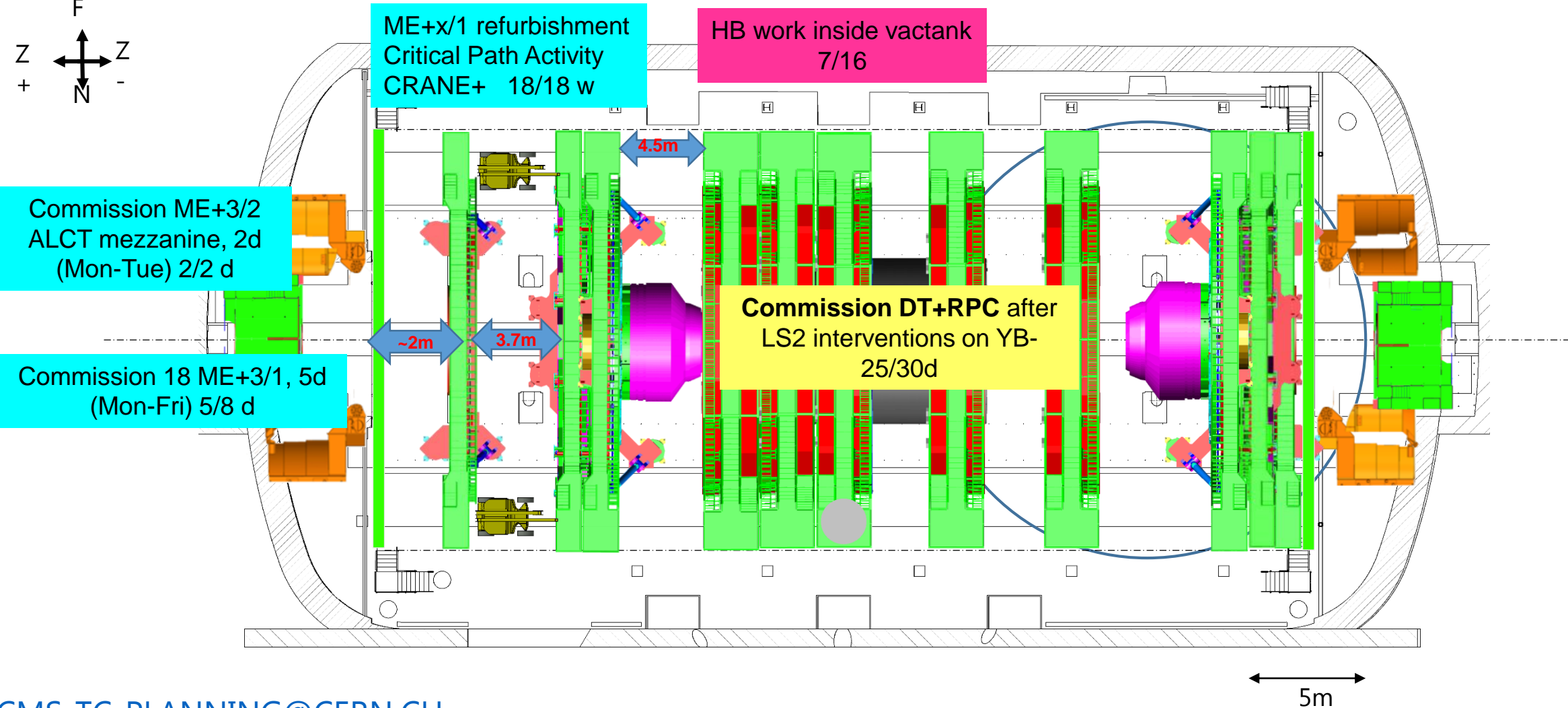





Crane

Cryo.	<span style="background-color: green; color: green;">■</span>	EL power	<span style="background-color: green; color: green;">■</span>	Water cool.	<span style="background-color: green; color: green;">■</span>	Database	<span style="background-color: green; color: green;">■</span>
IT	<span style="background-color: green; color: green;">■</span>	Magnet	<span style="background-color: red; color: red;">■</span>	C6F14	<span style="background-color: green; color: green;">■</span>	Gas	<span style="background-color: green; color: green;">■</span>
SL. 0	<span style="background-color: teal; color: white;">GEM</span>	<span style="background-color: blue; color: white;">ECAL</span>	<span style="background-color: green; color: white;">ZEC</span>	<span style="background-color: yellow; color: black;">DT+ RB</span>	<span style="background-color: grey; color: white;">Survey</span>	<span style="background-color: pink; color: black;">TE-VSC</span>	<span style="background-color: brown; color: white;">GS Dept</span>
CP. 0	<span style="background-color: olive; color: white;">TOTEM</span>	<span style="background-color: yellow; color: black;">CMX</span>	<span style="background-color: cyan; color: black;">CSC RE</span>	<span style="background-color: purple; color: white;">TK PIX</span>	<span style="background-color: magenta; color: black;">HCAL</span>	<span style="background-color: orange; color: black;">EN Dept</span>	<span style="border: 2px solid black; padding: 2px;"><b>RP</b></span>

PX56 Plug  
CLOSED

TX54 Plug  
CLOSED

2019

October – Week 43

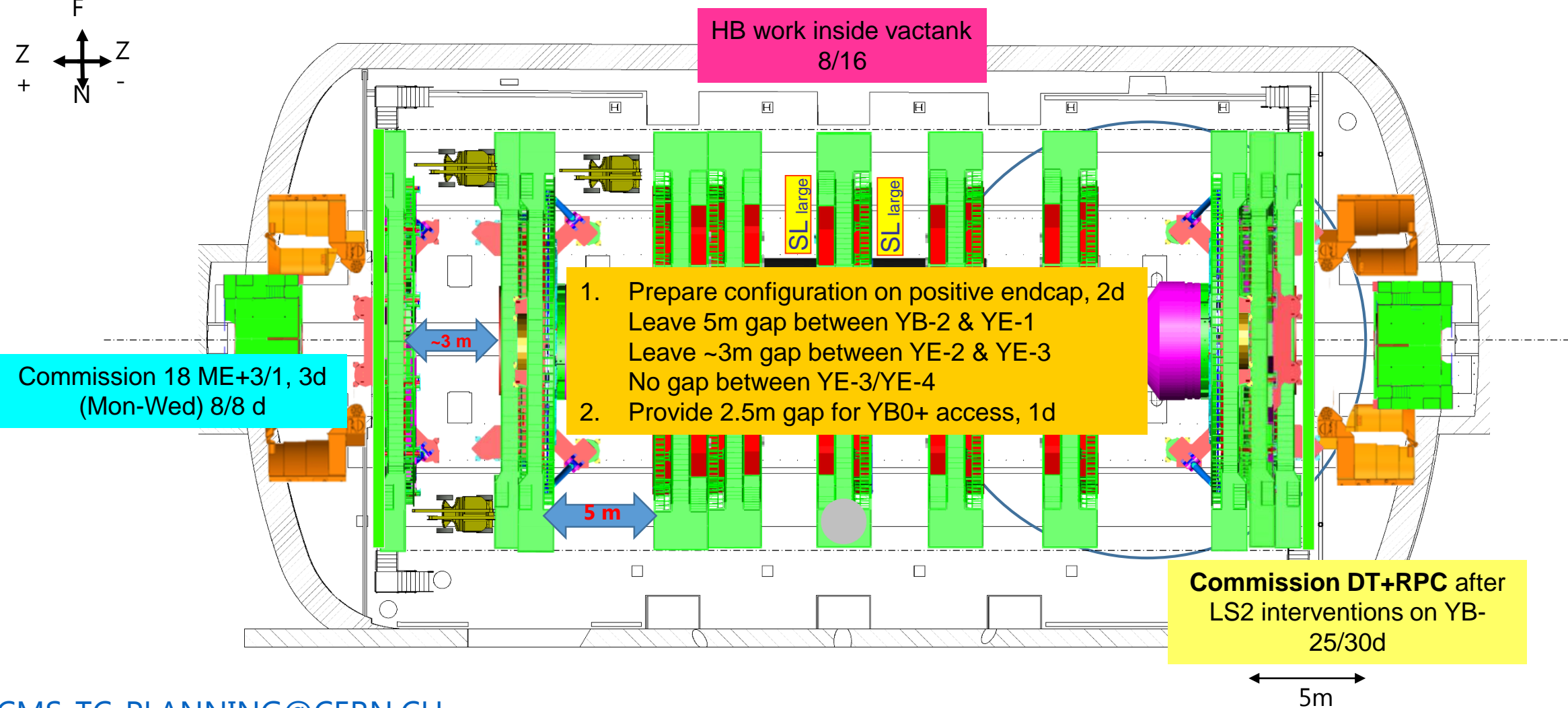
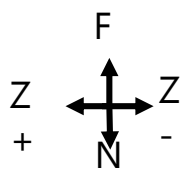

HB work inside vactank  
8/16

1. Prepare configuration on positive endcap, 2d  
Leave 5m gap between YB-2 & YE-1  
Leave ~3m gap between YE-2 & YE-3  
No gap between YE-3/YE-4
2. Provide 2.5m gap for YB0+ access, 1d

Commission 18 ME+3/1, 3d  
(Mon-Wed) 8/8 d

Commission DT+RPC after  
LS2 interventions on YB-  
25/30d

5m



Crane

Cryo.	█	EL power	█	Water cool.	█	Database	█
IT	█	Magnet	█	C6F14	█	Gas	█
SL. 0	GEM	ECAL	ZEC	DT+ RB	Survey	TE-VSC	GS Dept
CP. 0	TOTEM	CMX	CSC RE	TK PIX	HCAL	EN Dept	<b>RP</b>

PX56 Plug CLOSED
TX54 Plug CLOSED

2019
October – Week 44

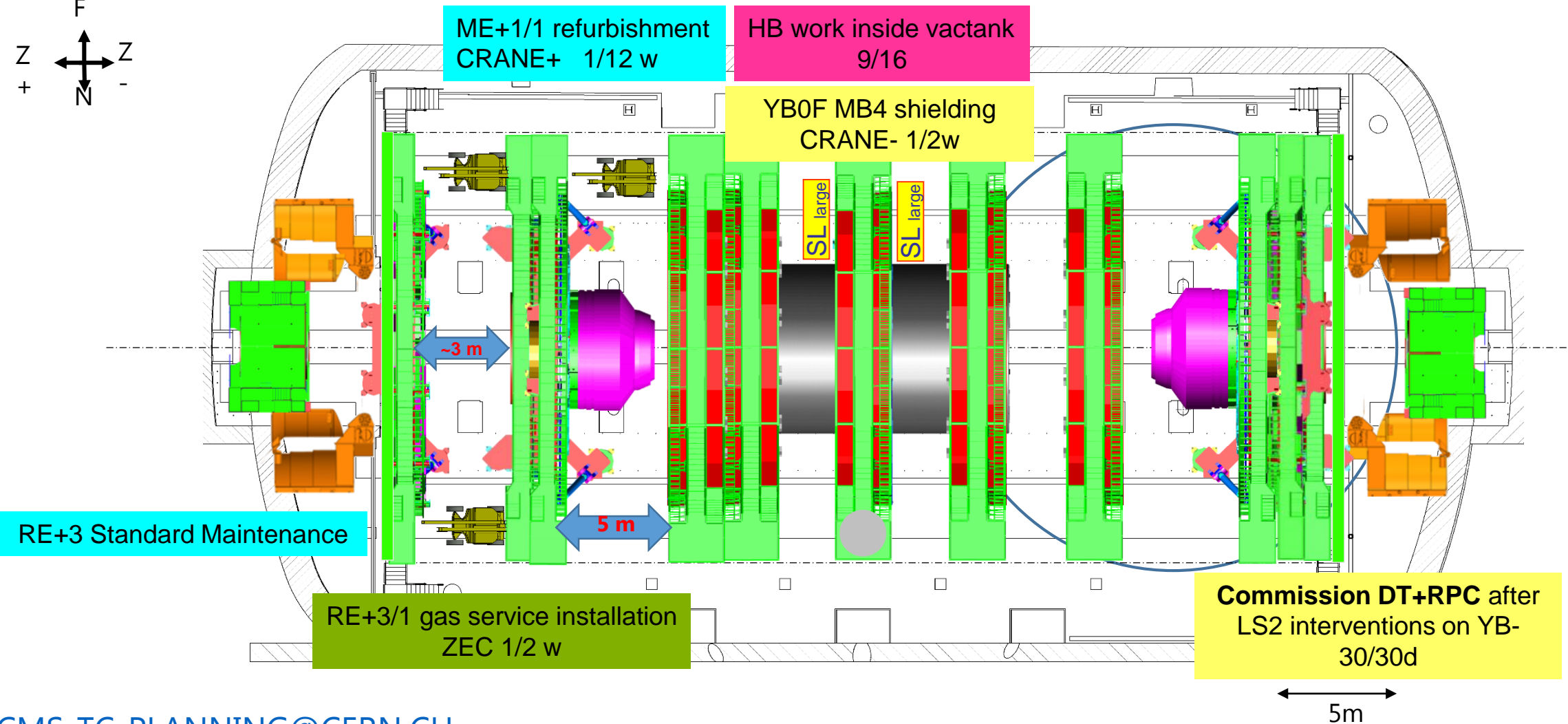
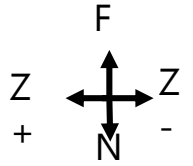



Crane

Cryo.	█	EL power	█	Water cool.	█	Database	█
IT	█	Magnet	█	C6F14	█	Gas	█
SL. 0	GEM	ECAL	ZEC	DT+ RB	Survey	TE-VSC	GS Dept
CP. 0	TOTEM	CMX	CSC RE	TK PIX	HCAL	EN Dept	<b>RP</b>

PX56 Plug CLOSED
TX54 Plug CLOSED

2019
November – Week 45

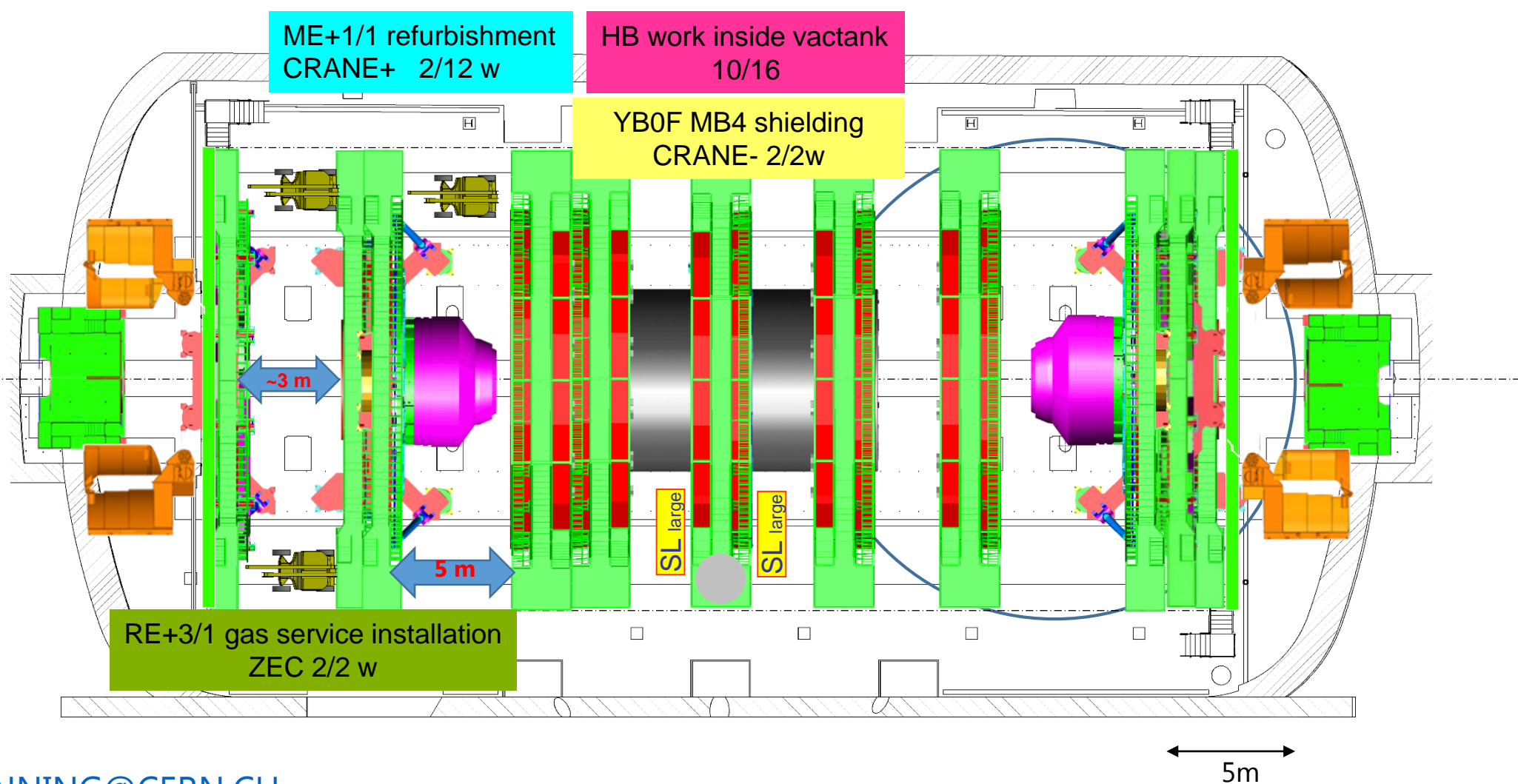
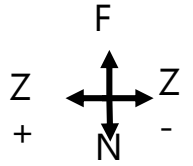



Crane

Cryo.	█	EL power	█	Water cool.	█	Database	█
IT	█	Magnet	█	C6F14	█	Gas	█
SL. 0	GEM	ECAL	ZEC	DT+ RB	Survey	TE-VSC	GS Dept
CP. 0	TOTEM	CMX	CSC RE	TK PIX	HCAL	EN Dept	<b>RP</b>

PX56 Plug  
CLOSED

TX54 Plug  
CLOSED

2019

November – Week 46

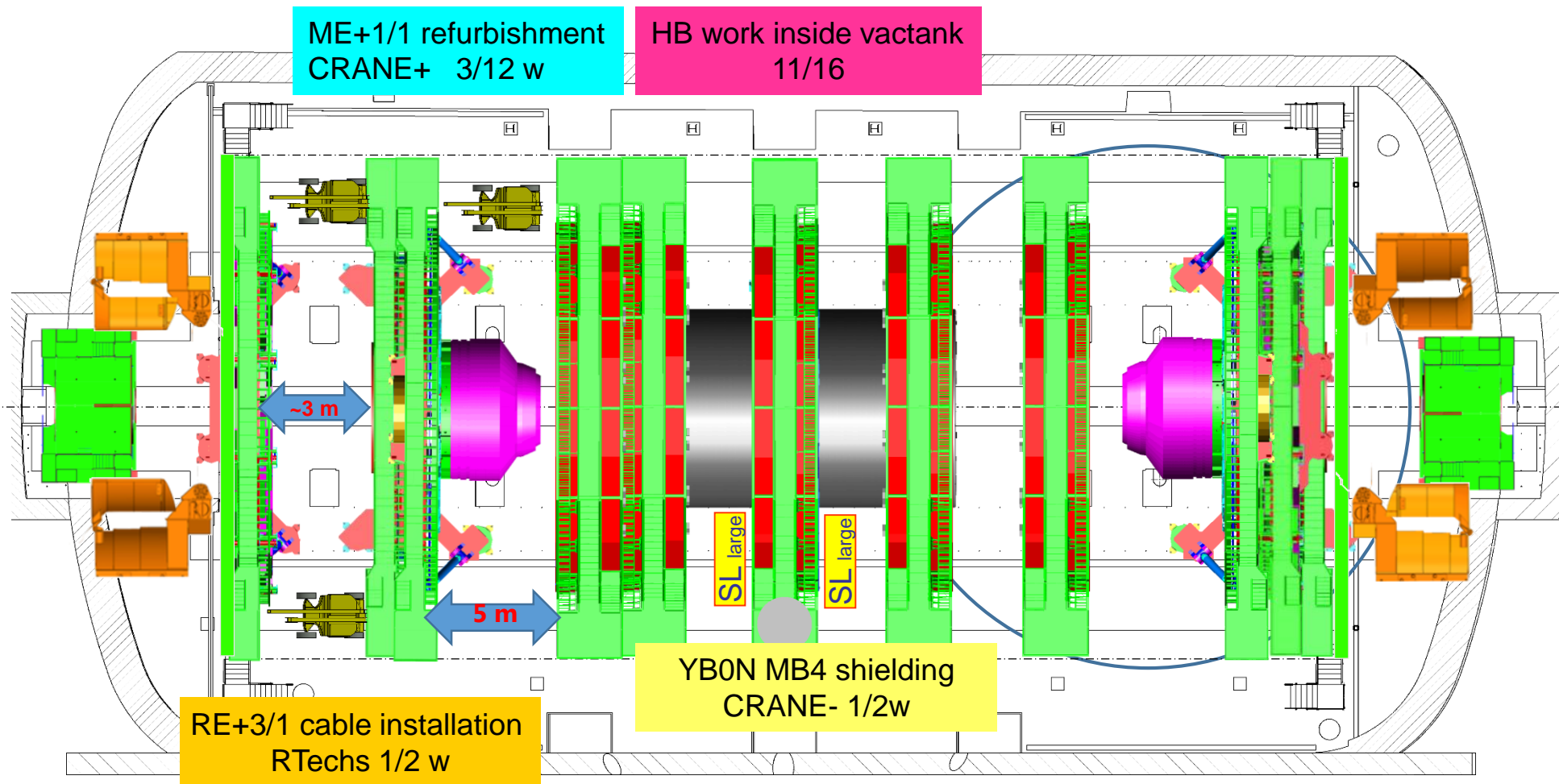
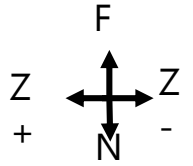

5m





Cryo.	█	EL power	█	Water cool.	█	Database	█
IT	█	Magnet	█	C6F14	█	Gas	█
SL. 0	GEM	ECAL	ZEC	DT+ RB	Survey	TE-VSC	GS Dept
CP. 0	TOTEM	CMX	CSC RE	TK PIX	HCAL	EN Dept	<b>RP</b>

PX56 Plug  
CLOSED

TX54 Plug  
CLOSED

2019

November – Week 47

Crane

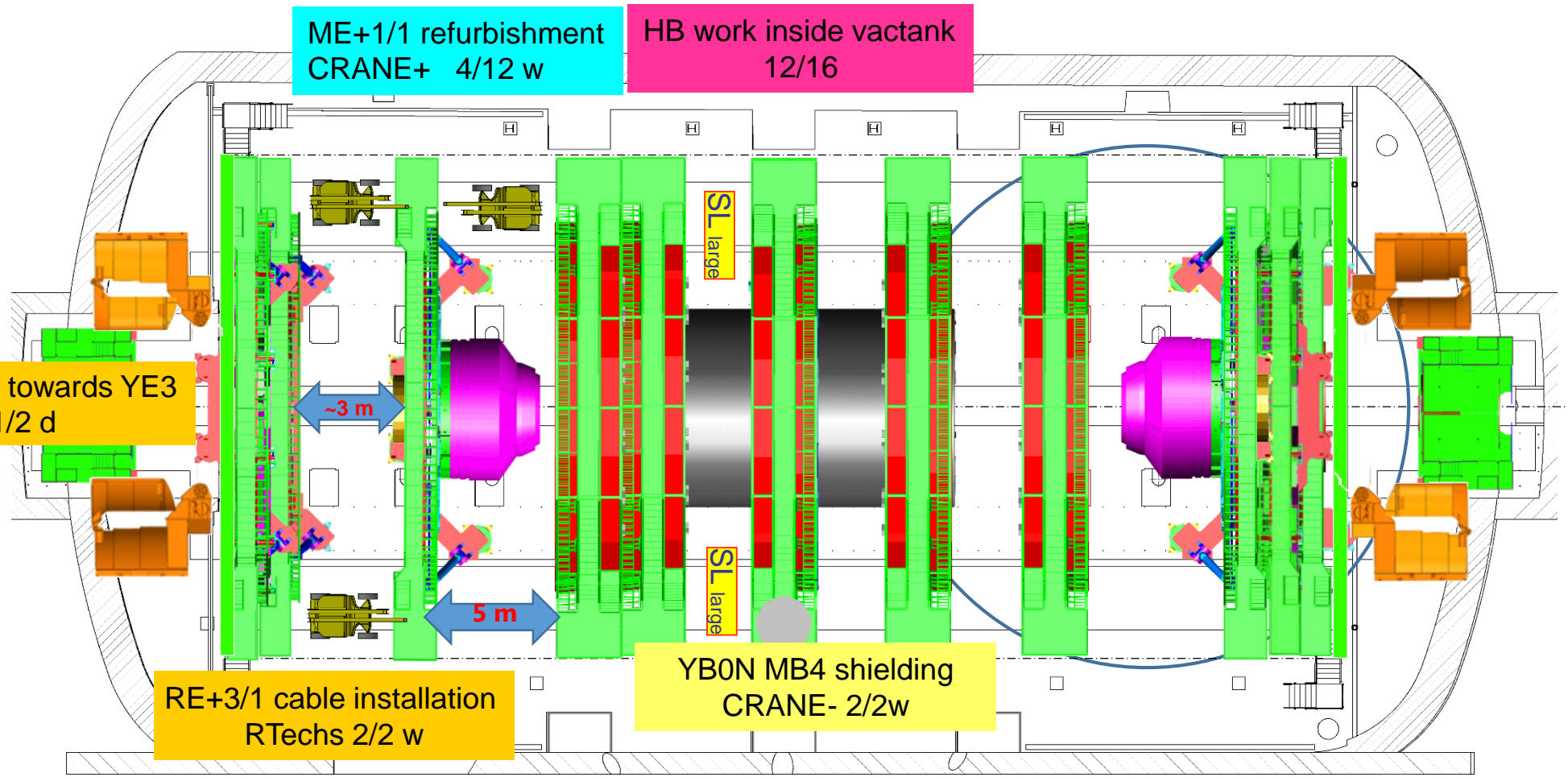

Move YE+2 disk towards YE3  
(Mon) 1/2 d

5m





Crane

Cryo.	<span style="background-color: green; color: green;">█</span>	EL power	<span style="background-color: green; color: green;">█</span>	Water cool.	<span style="background-color: green; color: green;">█</span>	Database	<span style="background-color: green; color: green;">█</span>
IT	<span style="background-color: green; color: green;">█</span>	Magnet	<span style="background-color: red; color: red;">█</span>	C6F14	<span style="background-color: green; color: green;">█</span>	Gas	<span style="background-color: green; color: green;">█</span>
SL. 0	<span style="background-color: teal; color: white;">GEM</span>	<span style="background-color: purple; color: white;">ECAL</span>	<span style="background-color: olive; color: white;">ZEC</span>	<span style="background-color: yellow; color: black;">DT+ RB</span>	<span style="background-color: grey; color: white;">Survey</span>	<span style="background-color: pink; color: black;">TE-VSC</span>	<span style="background-color: brown; color: white;">GS Dept</span>
CP. 0	<span style="background-color: olive; color: white;">TOTEM</span>	<span style="background-color: yellow; color: black;">CMX</span>	<span style="background-color: cyan; color: black;">CSC RE</span>	<span style="background-color: maroon; color: white;">TK PIX</span>	<span style="background-color: magenta; color: black;">HCAL</span>	<span style="background-color: orange; color: black;">EN Dept</span>	<span style="border: 2px solid black; padding: 2px;"><b>RP</b></span>

PX56 Plug  
CLOSED

2019

TX54 Plug  
CLOSED

November – Week 48

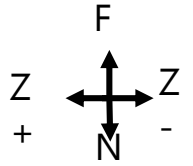

GE+2/1 gas service installation, 5d  
ZEC 1/2 w

ME+1/1 refurbishment  
CRANE+ 5/12 w

HB work inside vactank  
13/16

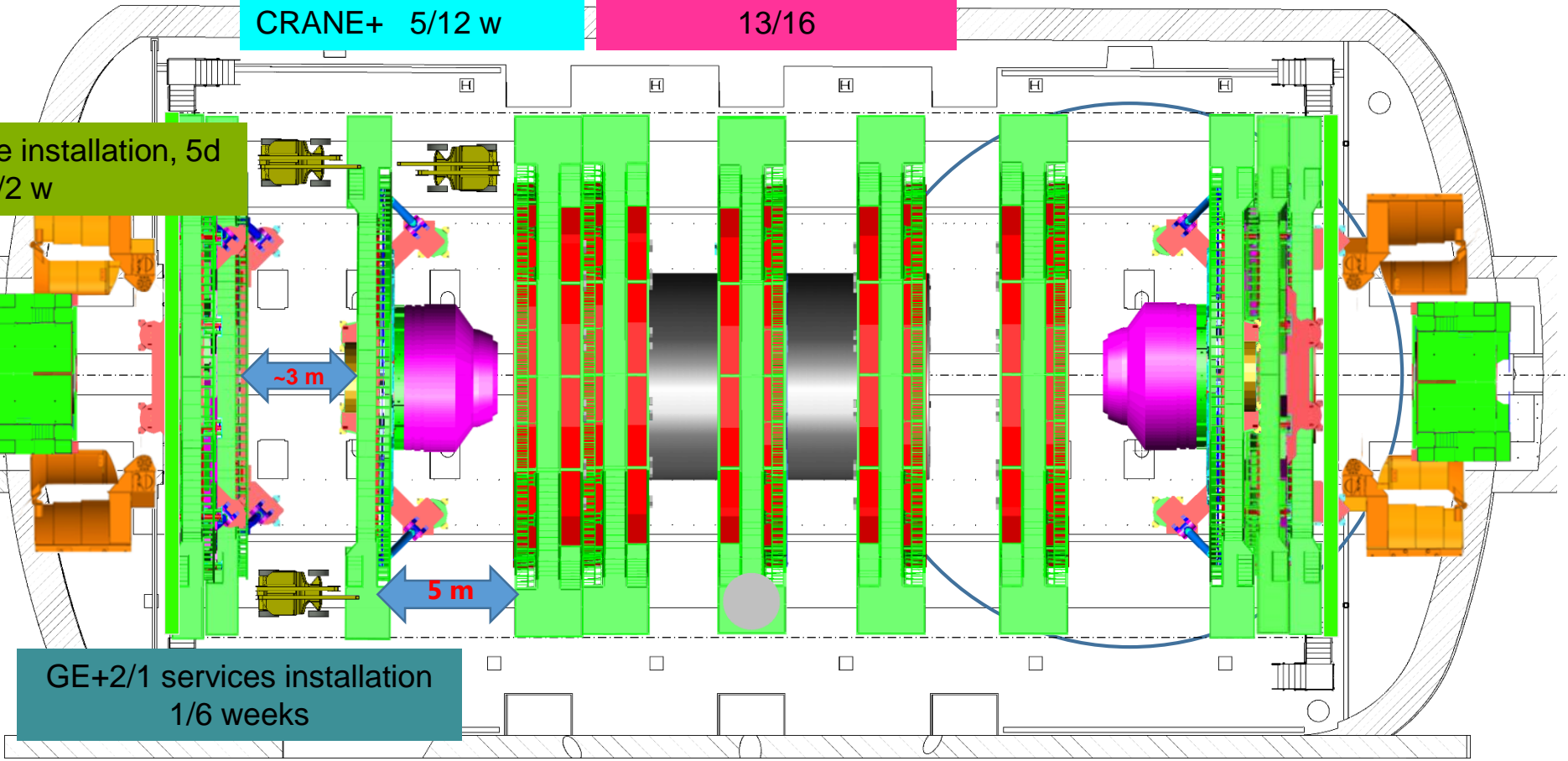

GE+2/1 services installation  
1/6 weeks

5m



Crane

Cryo.	█	EL power	█	Water cool.	█	Database	█								
IT	█	Magnet	█	C6F14	█	Gas	█								
SL.	0	GEM	█	ECAL	█	ZEC	█	DT+ RB	█	Survey	█	TE-VSC	█	GS Dept	█
CP.	0	TOTEM	█	CMX	█	CSC RE	█	TK PIX	█	HCAL	█	EN Dept	█	<b>RP</b>	█

PX56 Plug  
CLOSED

TX54 Plug  
CLOSED

2019

December – Week 49

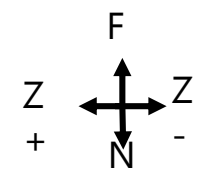

GE+2/1 gas service installation, 5d  
ZEC 2/2 w

ME+1/1 refurbishment  
CRANE+ 6/12 w

HB work inside vactank  
14/16

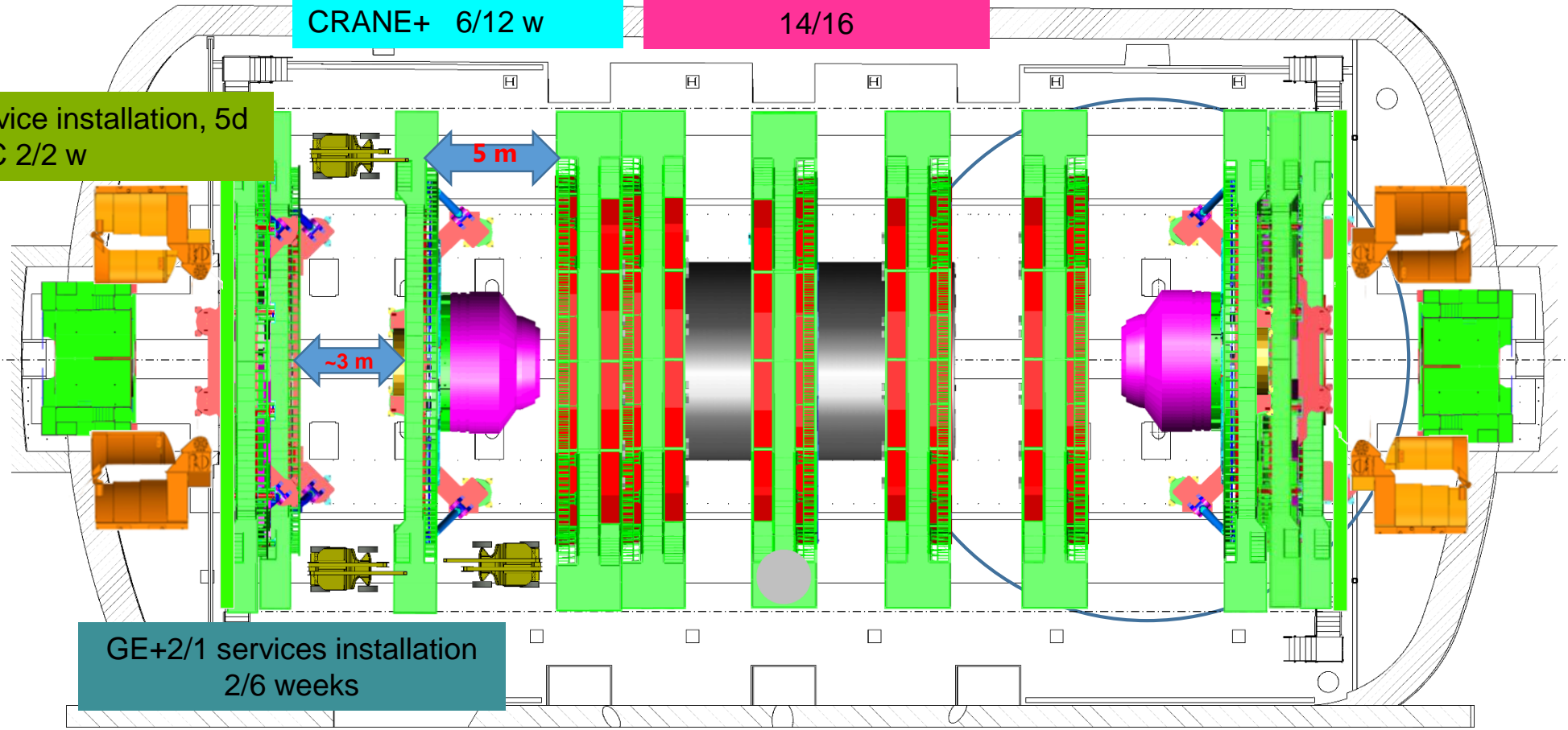

GE+2/1 services installation  
2/6 weeks

5m



Crane

Cryo.	<input type="checkbox"/>	EL power	<input type="checkbox"/>	Water cool.	<input type="checkbox"/>	Database	<input type="checkbox"/>
IT	<input type="checkbox"/>	Magnet	<input type="checkbox"/>	C6F14	<input type="checkbox"/>	Gas	<input type="checkbox"/>
SL. 0	GEM	ECAL	ZEC	DT+ RB	Survey	TE-VSC	GS Dept
CP. 0	TOTEM	CMX	CSC RE	TK PIX	HCAL	EN Dept	<b>RP</b>

PX56 Plug  
CLOSED

TX54 Plug  
CLOSED

2019

December – Week 50

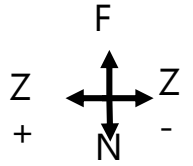

GE+2/1 cooling system installation, 5d  
ZEC 1/1 w

ME+1/1 refurbishment  
CRANE+ 7/12 w

HB work inside vactank  
15/16

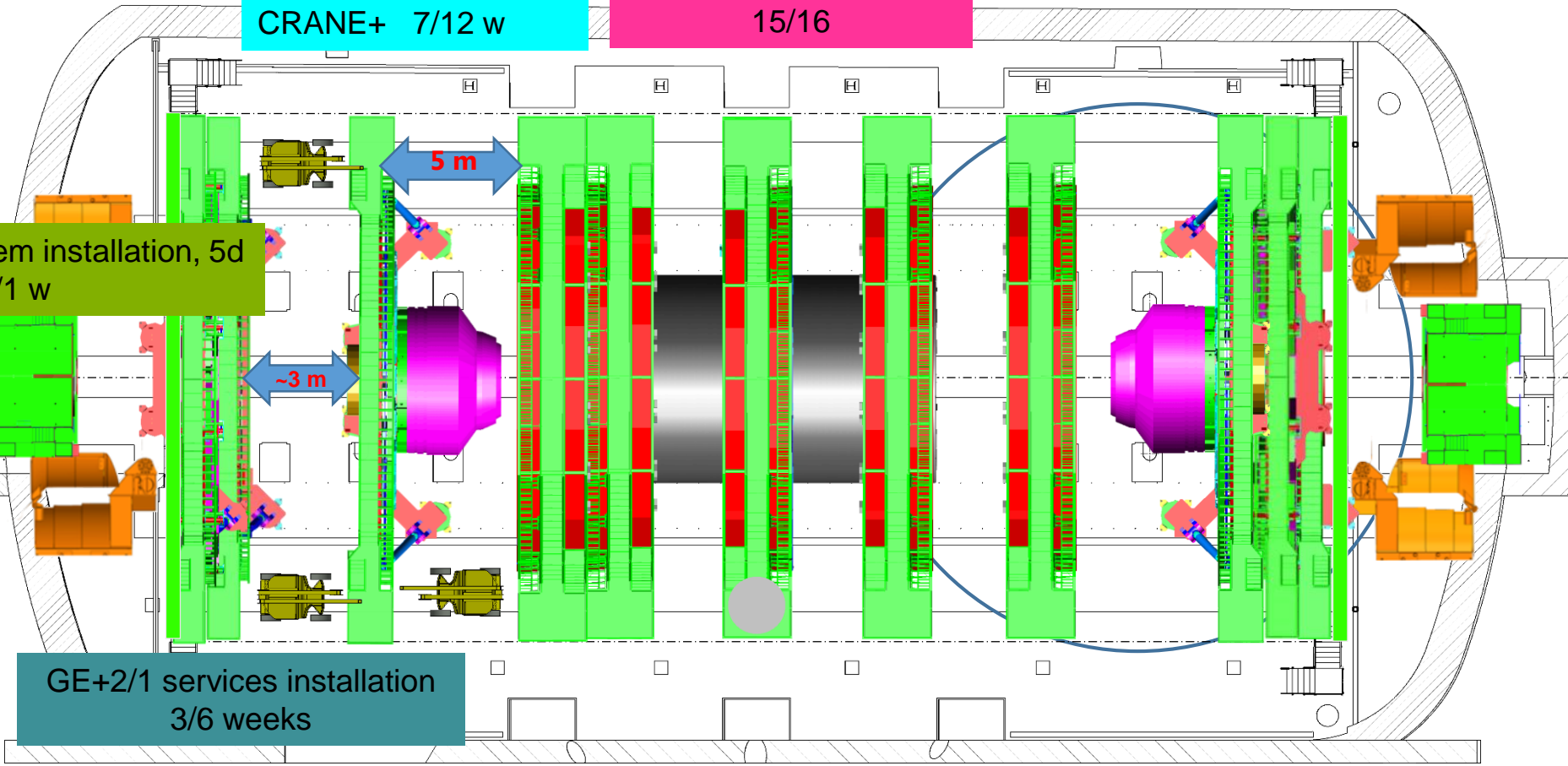

GE+2/1 services installation  
3/6 weeks

5m



Crane

Cryo.	█	EL power	█	Water cool.	█	Database	█
IT	█	Magnet	█	C6F14	█	Gas	█
SL. 0	GEM	ECAL	ZEC	DT+ RB	Survey	TE-VSC	GS Dept
CP. 0	TOTEM	CMX	CSC RE	TK PIX	HCAL	EN Dept	<b>RP</b>

PX56 Plug  
CLOSED

TX54 Plug  
CLOSED

2019

December – Week 51

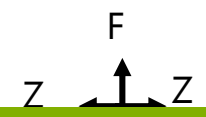

GE+2/1 gas leak test, 5d  
ZEC 2pers. 1CP, 2/2 w

ME+1/1 refurbishment  
CRANE+ 8/12 w

HB work inside vactank  
16/16

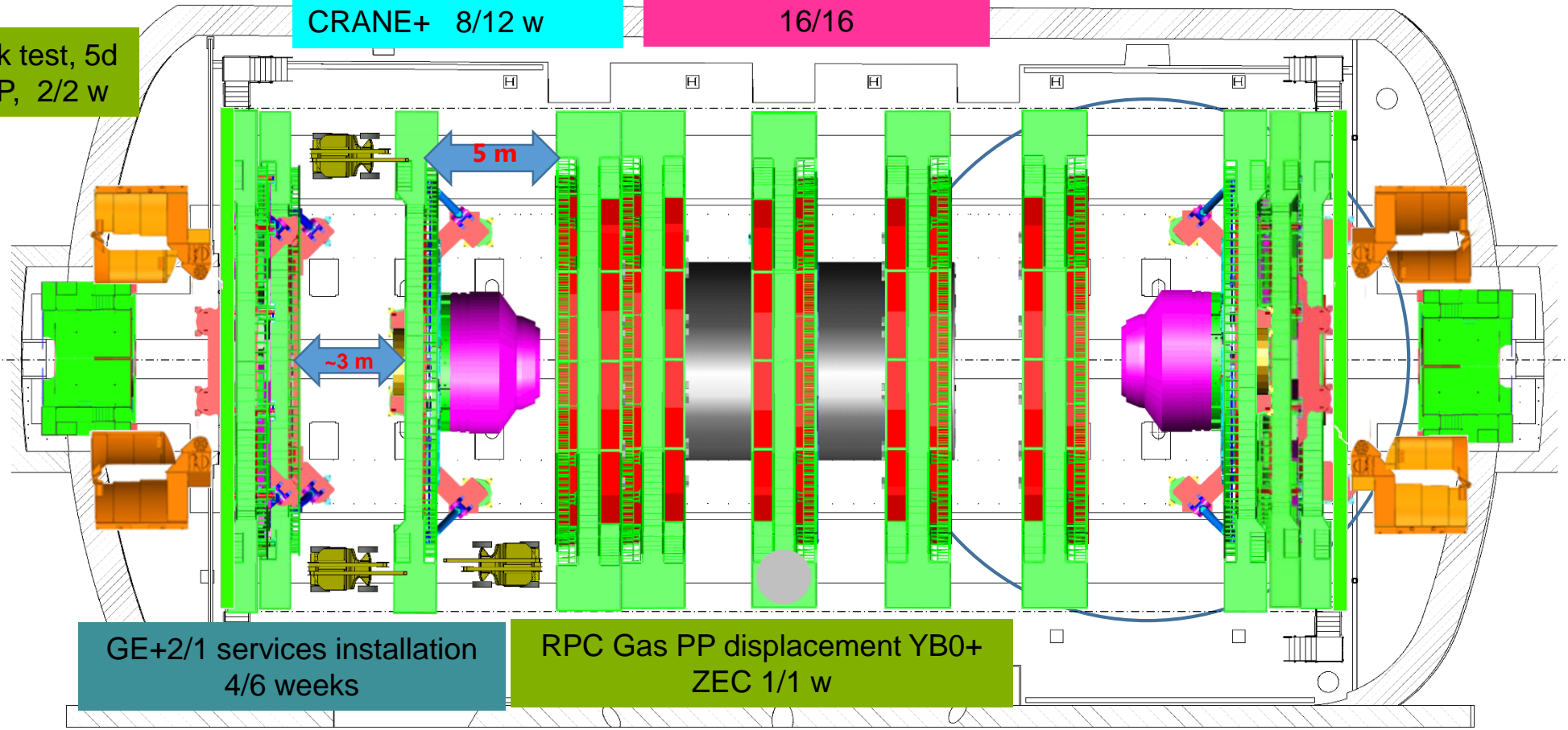

GE+2/1 services installation  
4/6 weeks

RPC Gas PP displacement YB0+  
ZEC 1/1 w

5m





Crane

Cryo.	<span style="background-color: green; color: green;">■</span>	EL power	<span style="background-color: green; color: green;">■</span>	Water cool.	<span style="background-color: green; color: green;">■</span>	Database	<span style="background-color: green; color: green;">■</span>
IT	<span style="background-color: green; color: green;">■</span>	Magnet	<span style="background-color: red; color: red;">■</span>	C6F14	<span style="background-color: green; color: green;">■</span>	Gas	<span style="background-color: green; color: green;">■</span>
SL. 0	<span style="background-color: teal; color: white;">GEM</span>	<span style="background-color: blue; color: white;">ECAL</span>	<span style="background-color: green; color: white;">ZEC</span>	<span style="background-color: yellow; color: black;">DT+ RB</span>	<span style="background-color: grey; color: white;">Survey</span>	<span style="background-color: pink; color: black;">TE-VSC</span>	<span style="background-color: brown; color: white;">GS Dept</span>
CP. 0	<span style="background-color: olive; color: white;">TOTEM</span>	<span style="background-color: yellow; color: black;">CMX</span>	<span style="background-color: cyan; color: black;">CSC RE</span>	<span style="background-color: purple; color: white;">TK PIX</span>	<span style="background-color: magenta; color: black;">HCAL</span>	<span style="background-color: orange; color: black;">EN Dept</span>	<span style="border: 2px solid black; padding: 2px;"><b>RP</b></span>

PX56 Plug  
CLOSED

TX54 Plug  
CLOSED

2019

December – Week 52

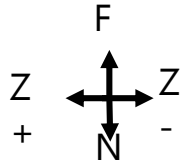

End of Year Lab Closure

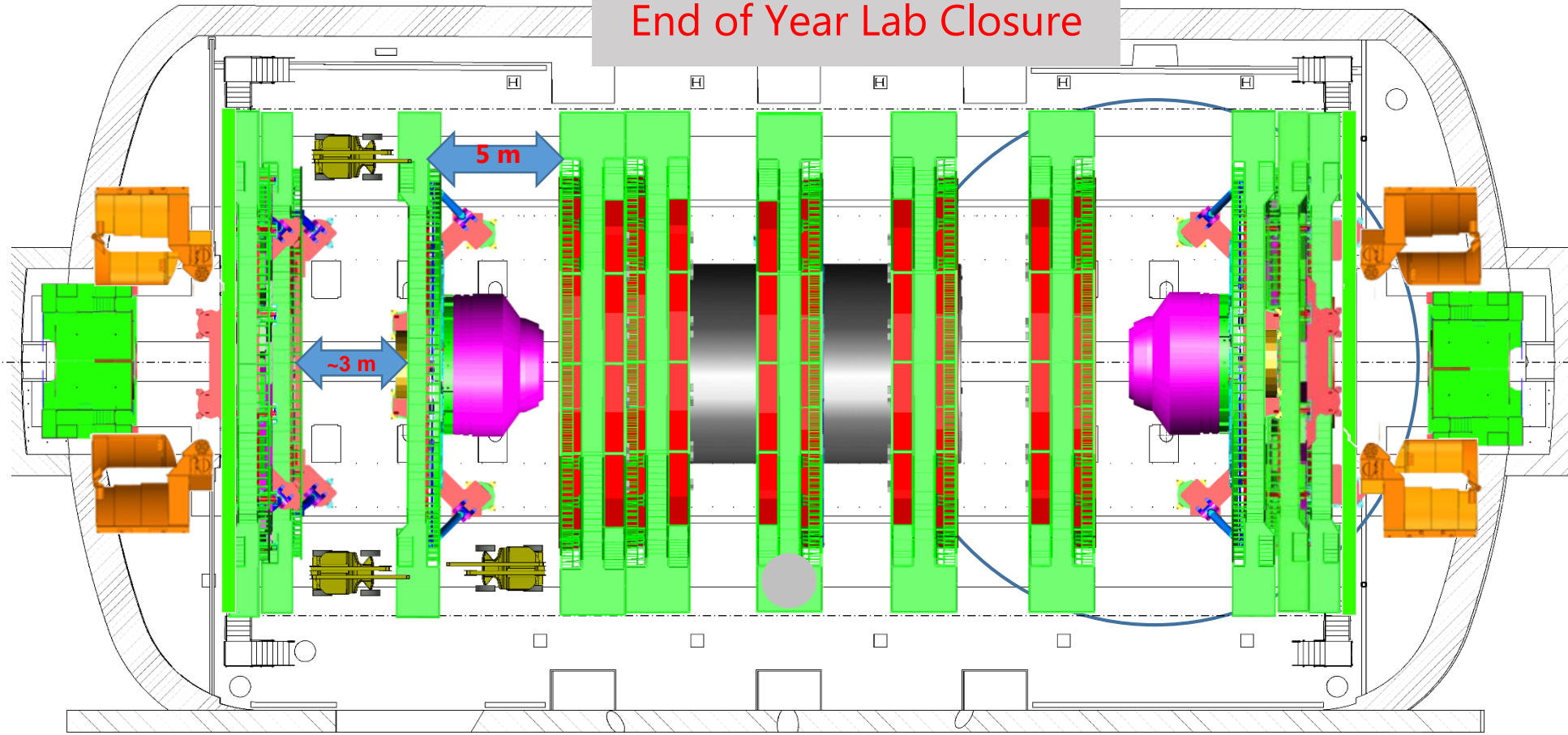

5m





Crane

Cryo.		EL power		Water cool.		Database								
IT		Magnet		C6F14		Gas								
SL. 0		GEM		ECAL		ZEC		DT+ RB		Survey		TE-VSC		GS Dept
CP. 0		TOTEM		CMX		CSC RE		TK PIX		HCAL		EN Dept		RP

PX56 Plug  
CLOSED

TX54 Plug  
CLOSED

2020

January – Week 1

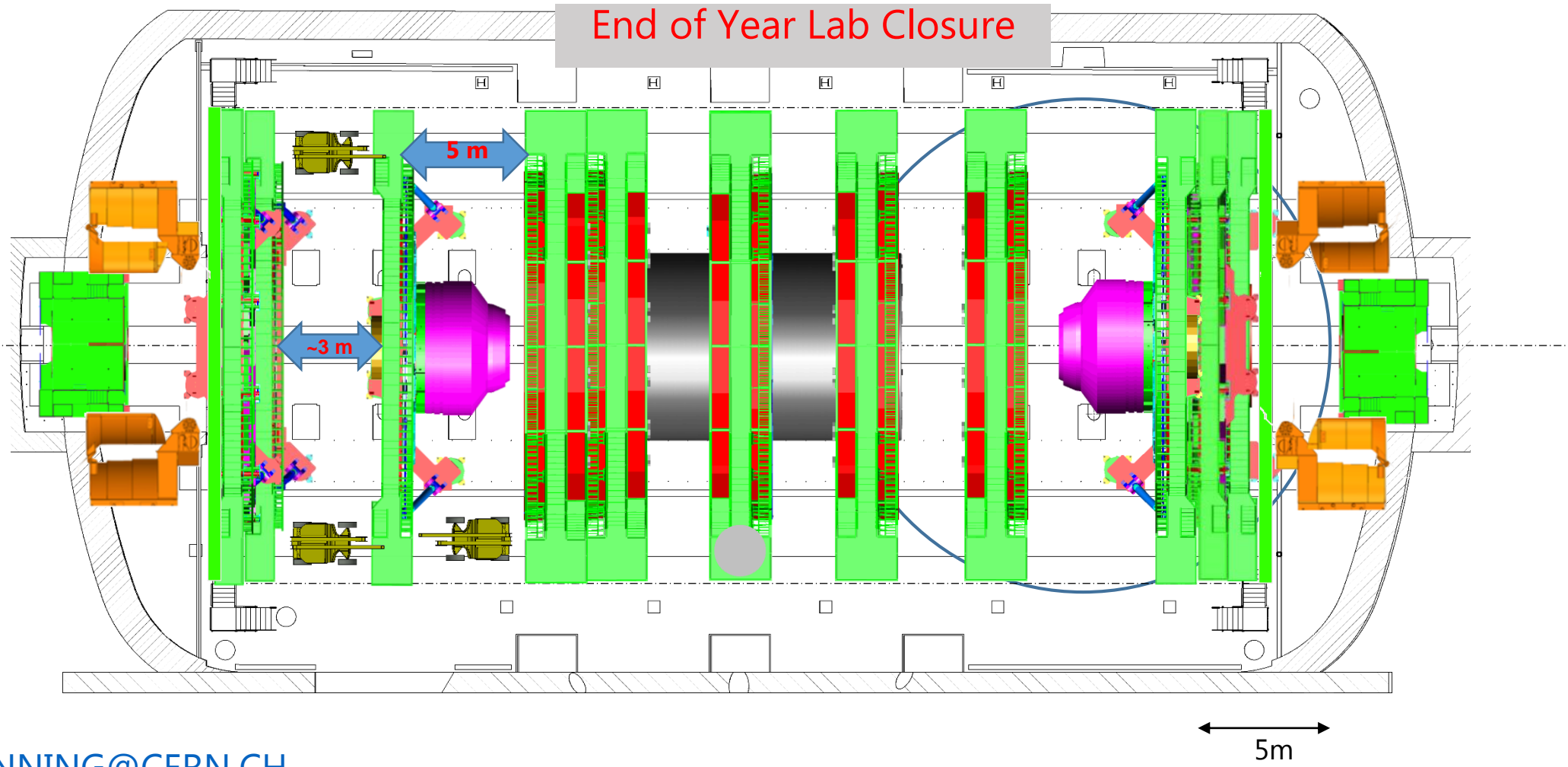
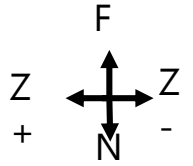



Crane

Cryo.		EL power		Water cool.		Database								
IT		Magnet		C6F14		Gas								
SL. 0		GEM		ECAL		ZEC		DT+ RB		Survey		TE-VSC		GS Dept
CP. 0		TOTEM		CMX		CSC RE		TK PIX		HCAL		EN Dept		RP

PX56 Plug  
CLOSED

TX54 Plug  
CLOSED

2020

January – Week 2

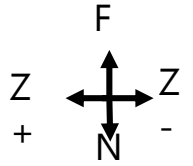

GE+2/1 cable installation, 5d  
RTechs 1/2 w

ME+1/1 refurbishment  
CRANE+ 9/12 w

GE+2/1 services installation  
5/6 weeks

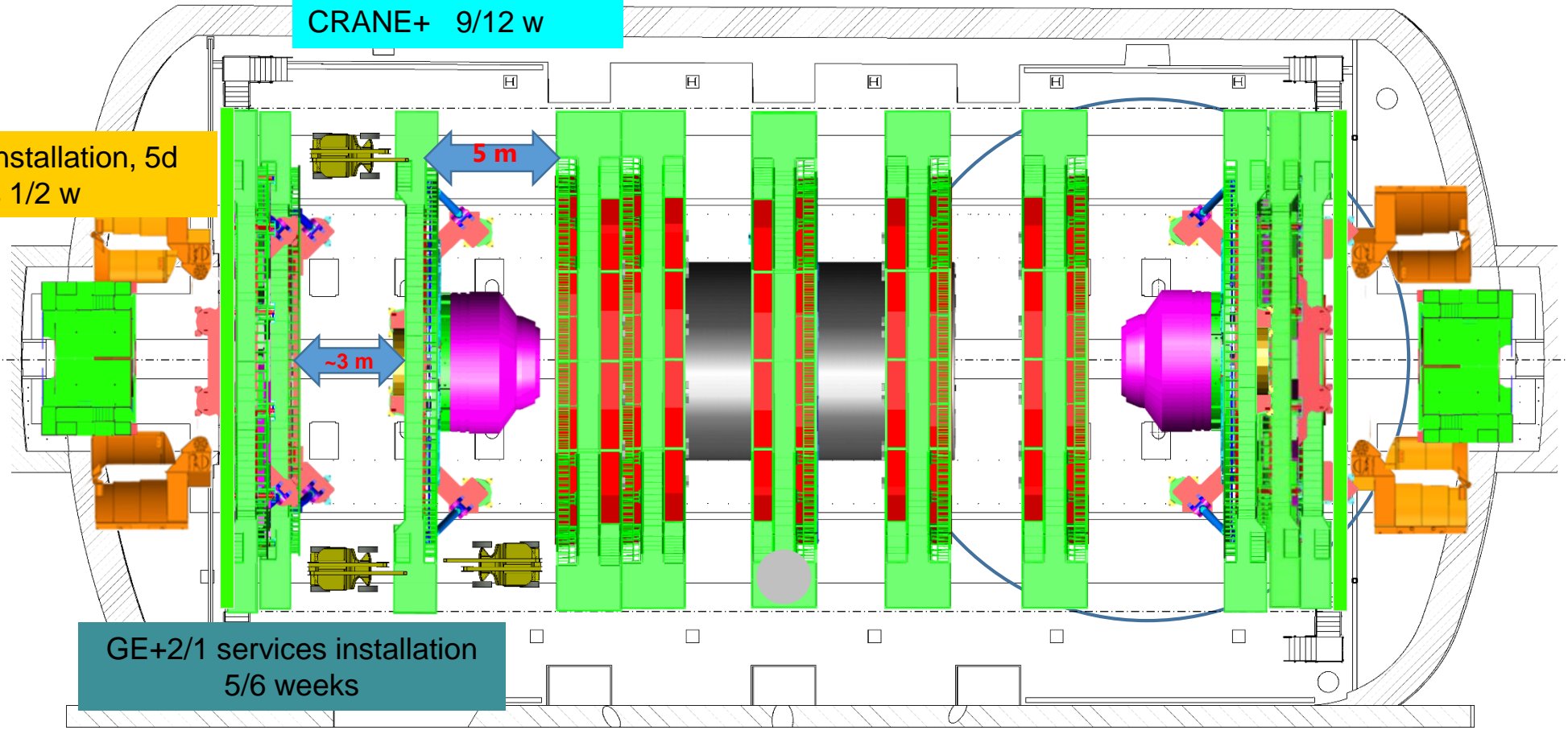

5m



Crane

Cryo.	█	EL power	█	Water cool.	█	Database	█
IT	█	Magnet	█	C6F14	█	Gas	█
SL. 0	GEM	ECAL	ZEC	DT+ RB	Survey	TE-VSC	GS Dept
CP. 0	TOTEM	CMX	CSC RE	TK PIX	HCAL	EN Dept	<b>RP</b>

PX56 Plug CLOSED
TX54 Plug CLOSED

2020
January – Week 3

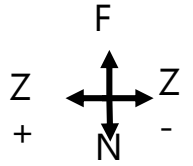

GE+2/1 cable installation, 5d  
RTechs 2/2 w

ME+1/1 refurbishment  
CRANE+ 10/12 w

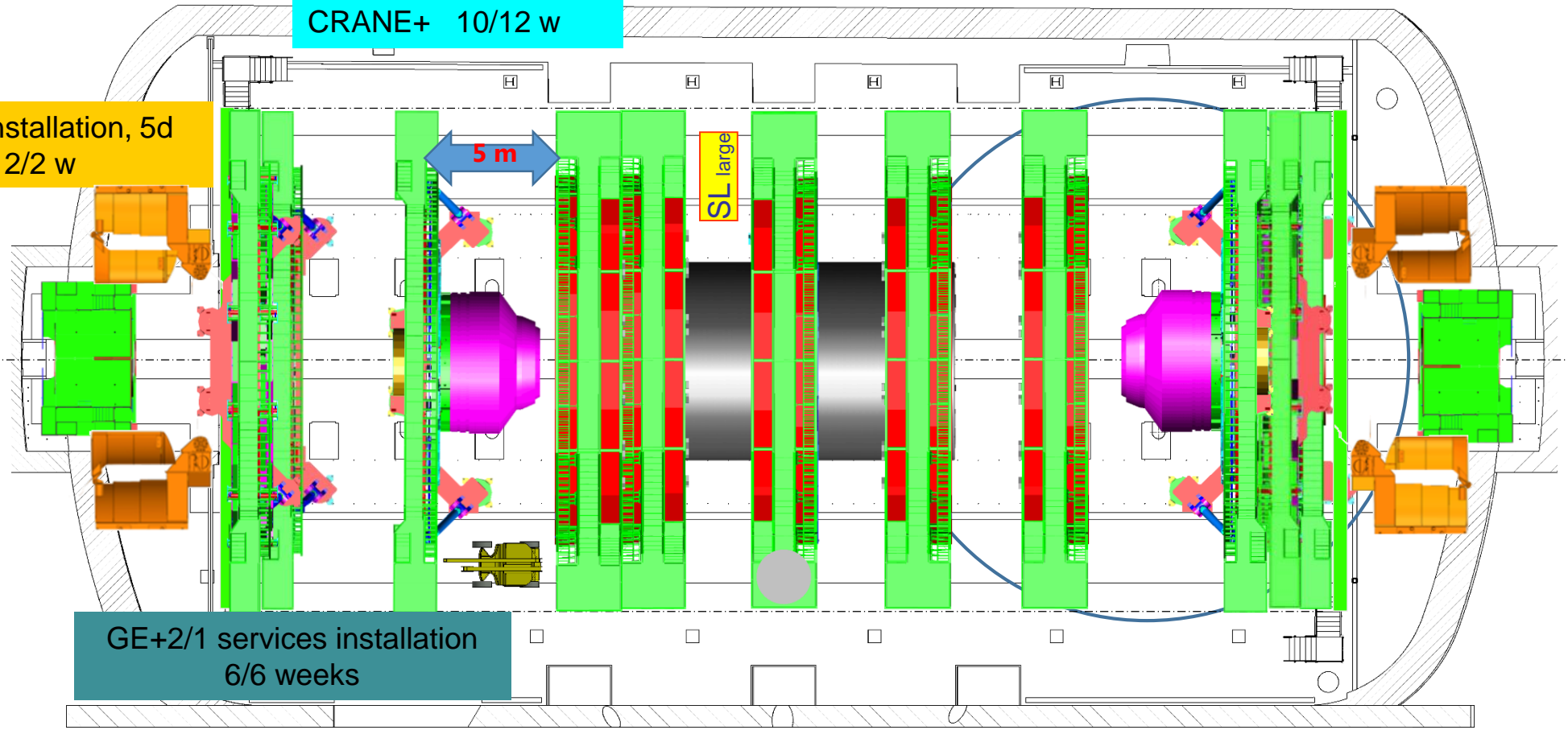

GE+2/1 services installation  
6/6 weeks

5m



Crane

Cryo.	■	EL power	■	Water cool.	■	Database	■
IT	■	Magnet	■	C6F14	■	Gas	■
SL. 0	GEM	ECAL	ZEC	DT+ RB	Survey	TE-VSC	GS Dept
CP. 0	TOTEM	CMX	CSC RE	TK PIX	HCAL	EN Dept	<b>RP</b>

PX56 Plug  
CLOSED

2020

TX54 Plug  
CLOSED

January – Week 4

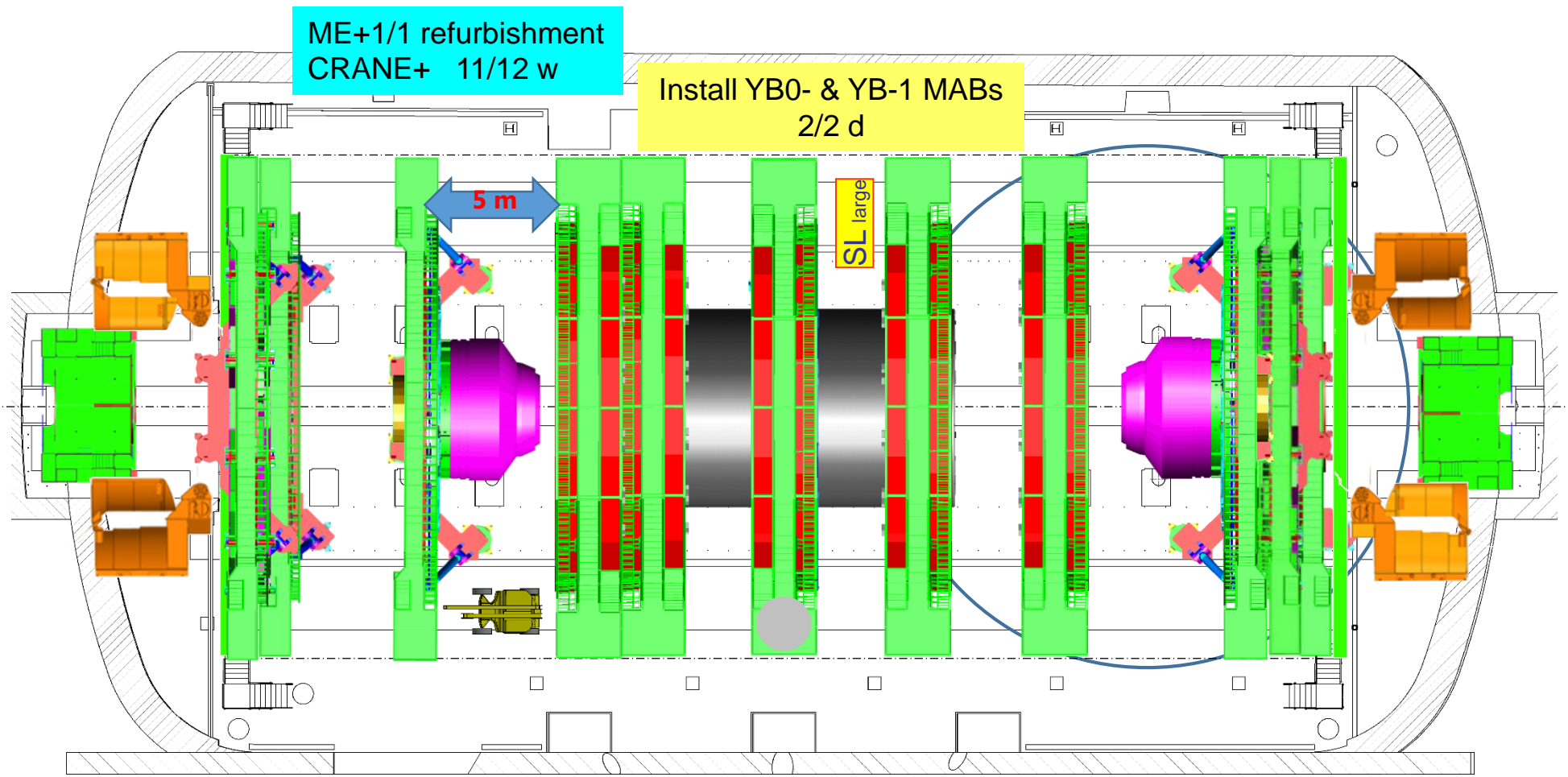
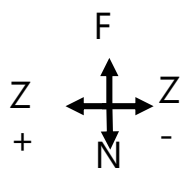

5m



Crane

Cryo.	█	EL power	█	Water cool.	█	Database	█
IT	█	Magnet	█	C6F14	█	Gas	█
SL. 0	GEM	ECAL	ZEC	DT+ RB	Survey	TE-VSC	GS Dept
CP. 0	TOTEM	CMX	CSC RE	TK PIX	HCAL	EN Dept	<b>RP</b>

PX56 Plug  
CLOSED

TX54 Plug  
CLOSED

2020

January – Week 5

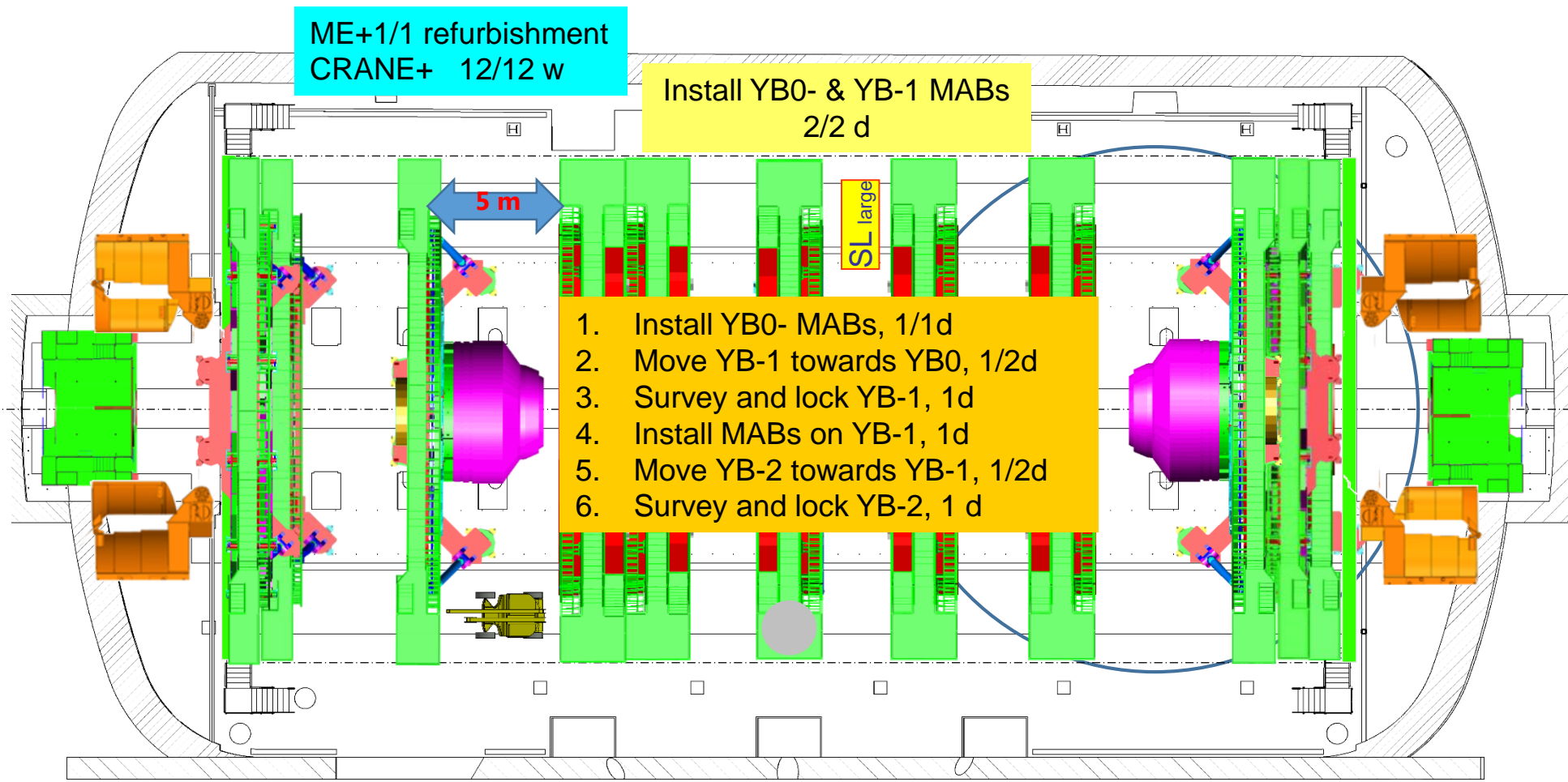
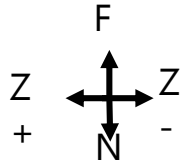





Crane

Cryo.	<span style="background-color: green; color: green;">■</span>	EL power	<span style="background-color: green; color: green;">■</span>	Water cool.	<span style="background-color: green; color: green;">■</span>	Database	<span style="background-color: green; color: green;">■</span>								
IT	<span style="background-color: green; color: green;">■</span>	Magnet	<span style="background-color: red; color: red;">■</span>	C6F14	<span style="background-color: green; color: green;">■</span>	Gas	<span style="background-color: green; color: green;">■</span>								
SL.	0	GEM	<span style="background-color: blue; color: white;">■</span>	ZEC	<span style="background-color: green; color: green;">■</span>	DT+ RB	<span style="background-color: yellow; color: black;">■</span>	Survey	<span style="background-color: grey; color: white;">■</span>	TE-VSC	<span style="background-color: pink; color: black;">■</span>	GS Dept	<span style="background-color: brown; color: white;">■</span>		
CP.	0	TOTEM	<span style="background-color: olive; color: white;">■</span>	CMX	<span style="background-color: yellow; color: black;">■</span>	CSC RE	<span style="background-color: cyan; color: black;">■</span>	TK PIX	<span style="background-color: purple; color: white;">■</span>	HCAL	<span style="background-color: magenta; color: black;">■</span>	EN Dept	<span style="background-color: orange; color: white;">■</span>	<b>RP</b>	<span style="background-color: white; color: black; border: 1px solid black;">■</span>

PX56 Plug CLOSED
TX54 Plug CLOSED

2020
January – Week 6

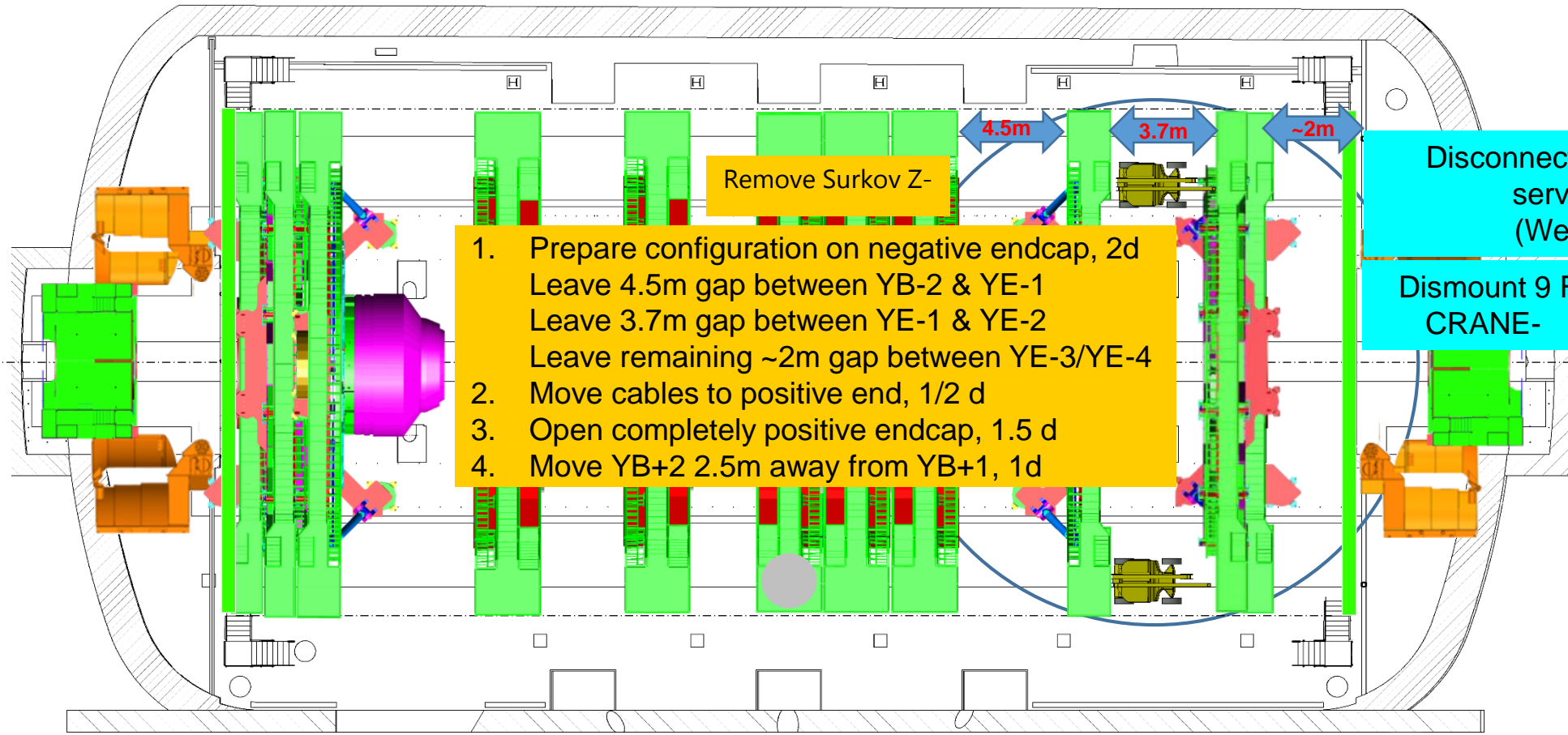
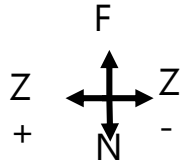

Remove Surkov Z-

1. Prepare configuration on negative endcap, 2d  
 Leave 4.5m gap between YB-2 & YE-1  
 Leave 3.7m gap between YE-1 & YE-2  
 Leave remaining ~2m gap between YE-3/YE-4
2. Move cables to positive end, 1/2 d
3. Open completely positive endcap, 1.5 d
4. Move YB+2 2.5m away from YB+1, 1d

Disconnect Front ME-2/1 services, 1d (Wed) 1/1 d

Dismount 9 Front ME-2/1, 2d CRANE- (Thu-Fri) 2/2 d

5m



Crane

Cryo.	█	EL power	█	Water cool.	█	Database	█								
IT	█	Magnet	█	C6F14	█	Gas	█								
SL.	0	GEM	█	ECAL	█	ZEC	█	DT+ RB	█	Survey	█	TE-VSC	█	GS Dept	█
CP.	0	TOTEM	█	CMX	█	CSC RE	█	TK PIX	█	HCAL	█	EN Dept	█	<b>RP</b>	█

PX56 Plug  
CLOSED

TX54 Plug  
CLOSED

2020

February – Week 7

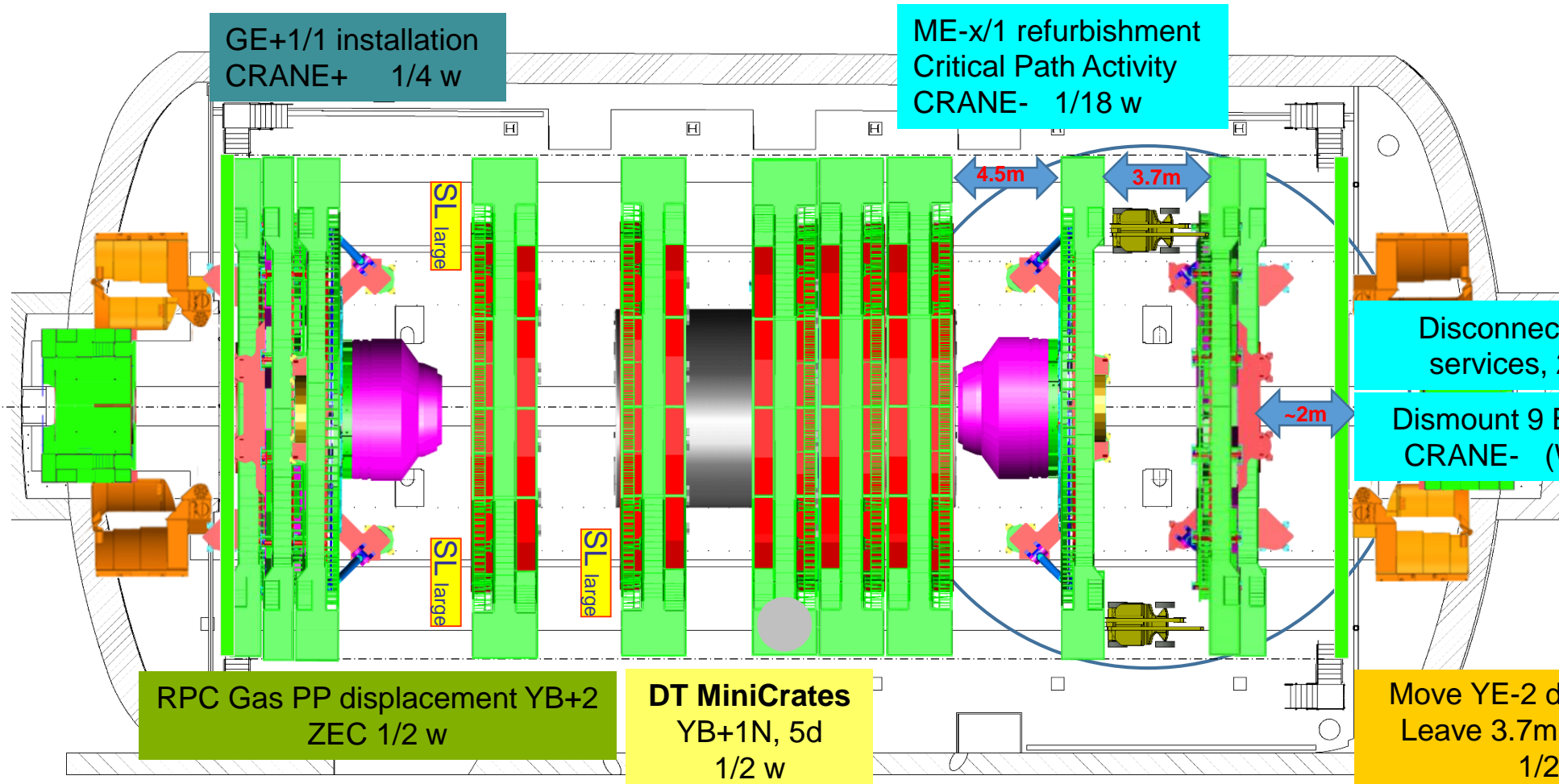
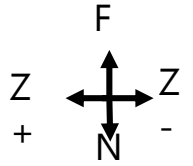

Disconnect Back ME-2/1 services, 2d (Mon-Tue)

Dismount 9 Back ME-2/1, 2d CRANE- (Wed-Thu) 2/2 d

Move YE-2 disk towards YE1  
Leave 3.7m gap YE-2/YE-3  
1/2 d (Fri)

5m



Crane

Cryo.	█	EL power	█	Water cool.	█	Database	█								
IT	█	Magnet	█	C6F14	█	Gas	█								
SL.	0	GEM	█	ECAL	█	ZEC	█	DT+ RB	█	Survey	█	TE-VSC	█	GS Dept	█
CP.	0	TOTEM	█	CMX	█	CSC RE	█	TK PIX	█	HCAL	█	EN Dept	█	<b>RP</b>	█

PX56 Plug  
CLOSED

TX54 Plug  
CLOSED

2020

February – Week 8

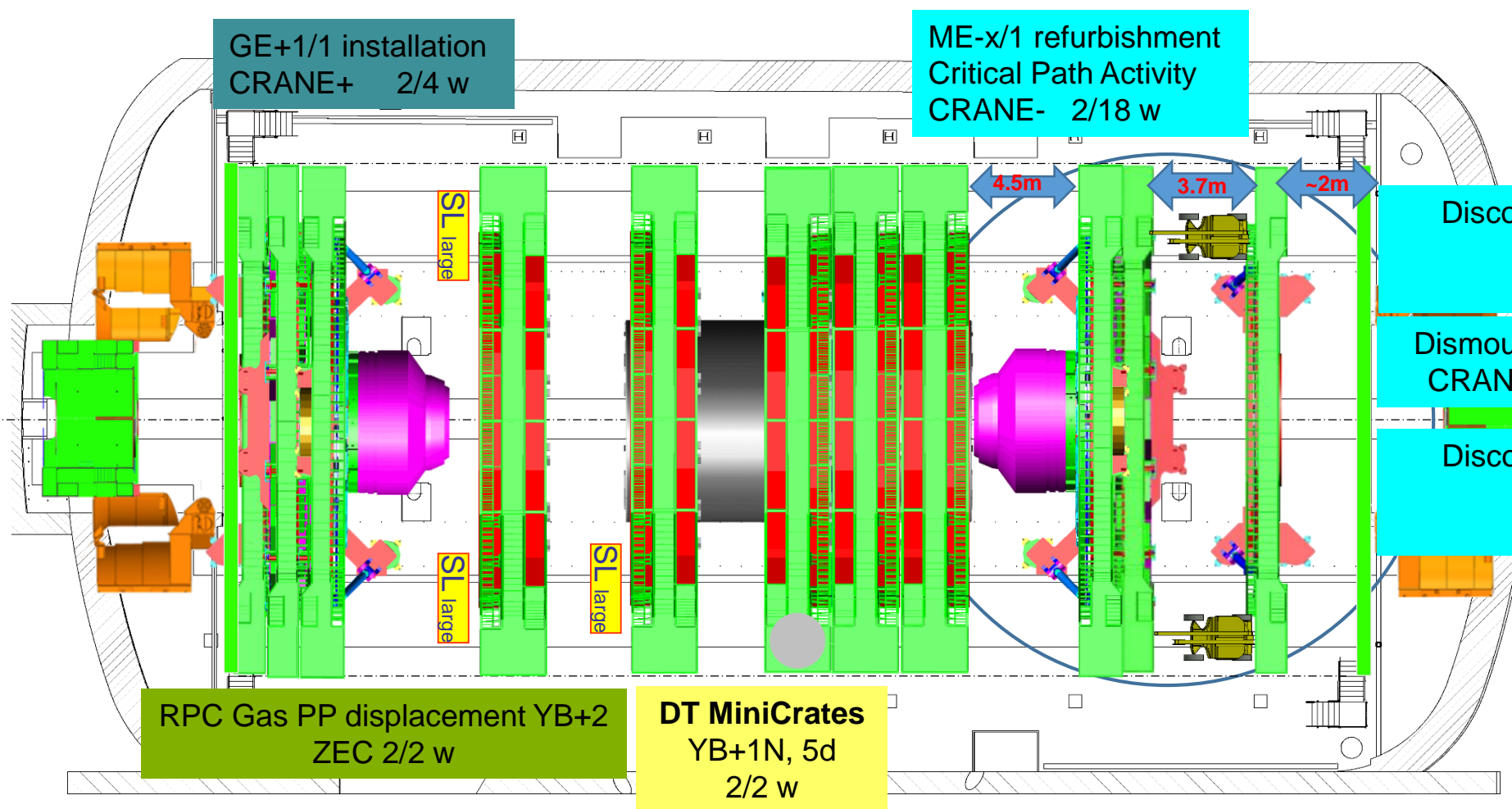
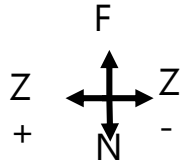

Disconnect Front ME-3/1 services, 1d (Mon) 1/1 d

Dismount 9 Front ME-3/1, 2d CRANE- (Tue-Wed) 2/2 d

Disconnect Back ME-3/1 services, 2d (Thu-Fri) 2/2 d

5m



Crane

Cryo.		EL power		Water cool.		Database									
IT		Magnet		C6F14		Gas									
SL. 0		GEM		ZEC		DT+ RB		Survey		TE-VSC		GS Dept			
CP. 0		TOTEM		CMX		CSC RE		TK PIX		HCAL		EN Dept		<b>RP</b>	

PX56 Plug  
CLOSED

TX54 Plug  
CLOSED

2020

February – Week 9

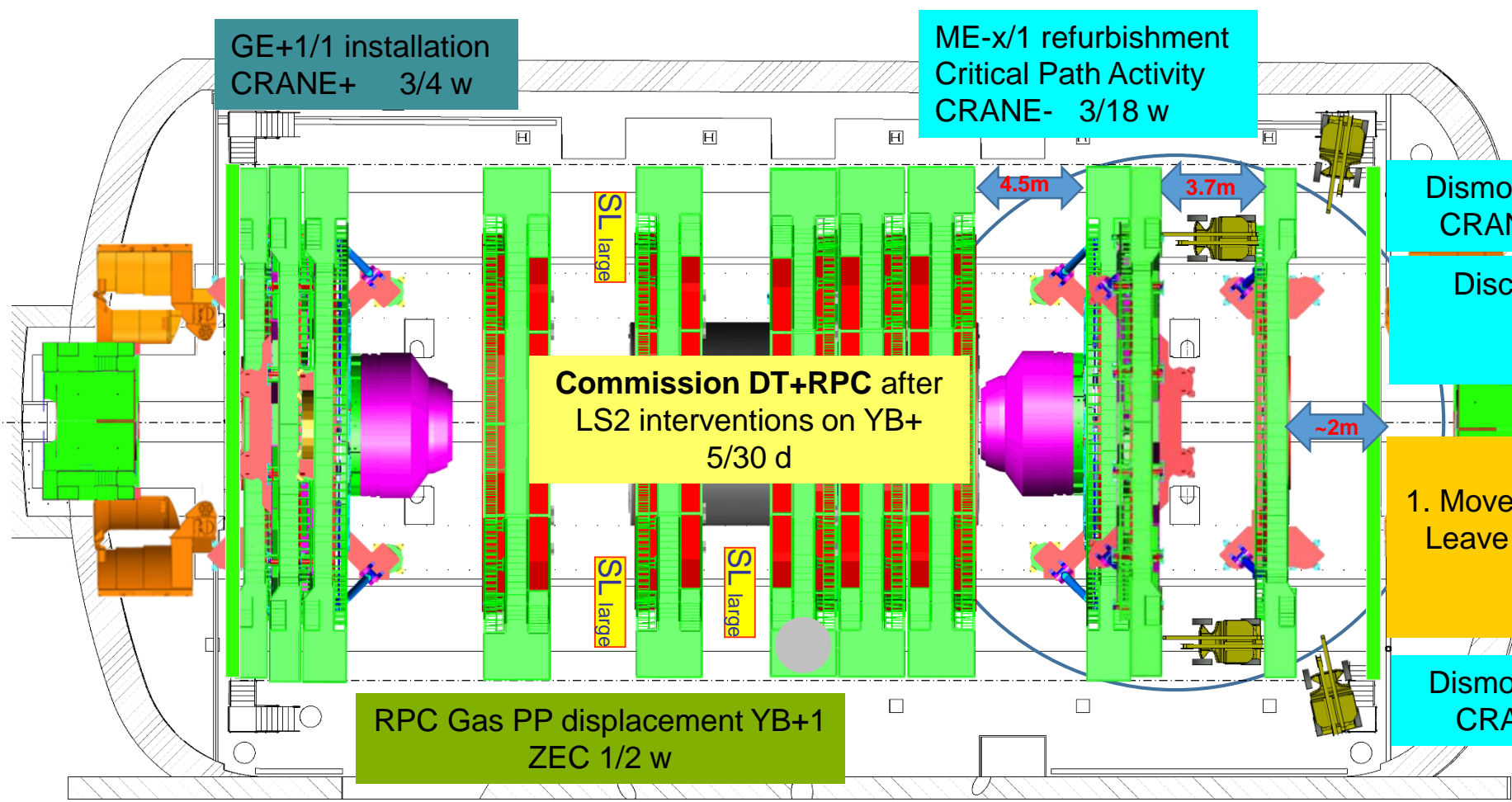
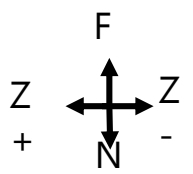

Dismount 9 Back ME-3/1, 2d  
CRANE- (Mon-Tue) 2/2 d

Disconnect Front ME-4/1  
services, 1d  
(Tue) 1/1 d

1. Move YE-3 disk towards YE2  
Leave ~5.5m gap YE-3/YE-4  
(Wed) 1 d

Dismount 9 Front ME-4/1, 2d  
CRANE- (Thu-Fri) 2/2 d

5m





Crane

Cryo.	<span style="background-color: green; width: 15px; height: 15px; display: inline-block;"></span>	EL power	<span style="background-color: green; width: 15px; height: 15px; display: inline-block;"></span>	Water cool.	<span style="background-color: green; width: 15px; height: 15px; display: inline-block;"></span>	Database	<span style="background-color: green; width: 15px; height: 15px; display: inline-block;"></span>
IT	<span style="background-color: green; width: 15px; height: 15px; display: inline-block;"></span>	Magnet	<span style="background-color: red; width: 15px; height: 15px; display: inline-block;"></span>	C6F14	<span style="background-color: green; width: 15px; height: 15px; display: inline-block;"></span>	Gas	<span style="background-color: green; width: 15px; height: 15px; display: inline-block;"></span>
SL. 0	GEM	ECAL	ZEC	DT+ RB	Survey	TE-VSC	GS Dept
CP. 0	TOTEM	CMX	CSC RE	TK PIX	HCAL	EN Dept	<b>RP</b>

PX56 Plug CLOSED
TX54 Plug CLOSED

2020
March – Week 10

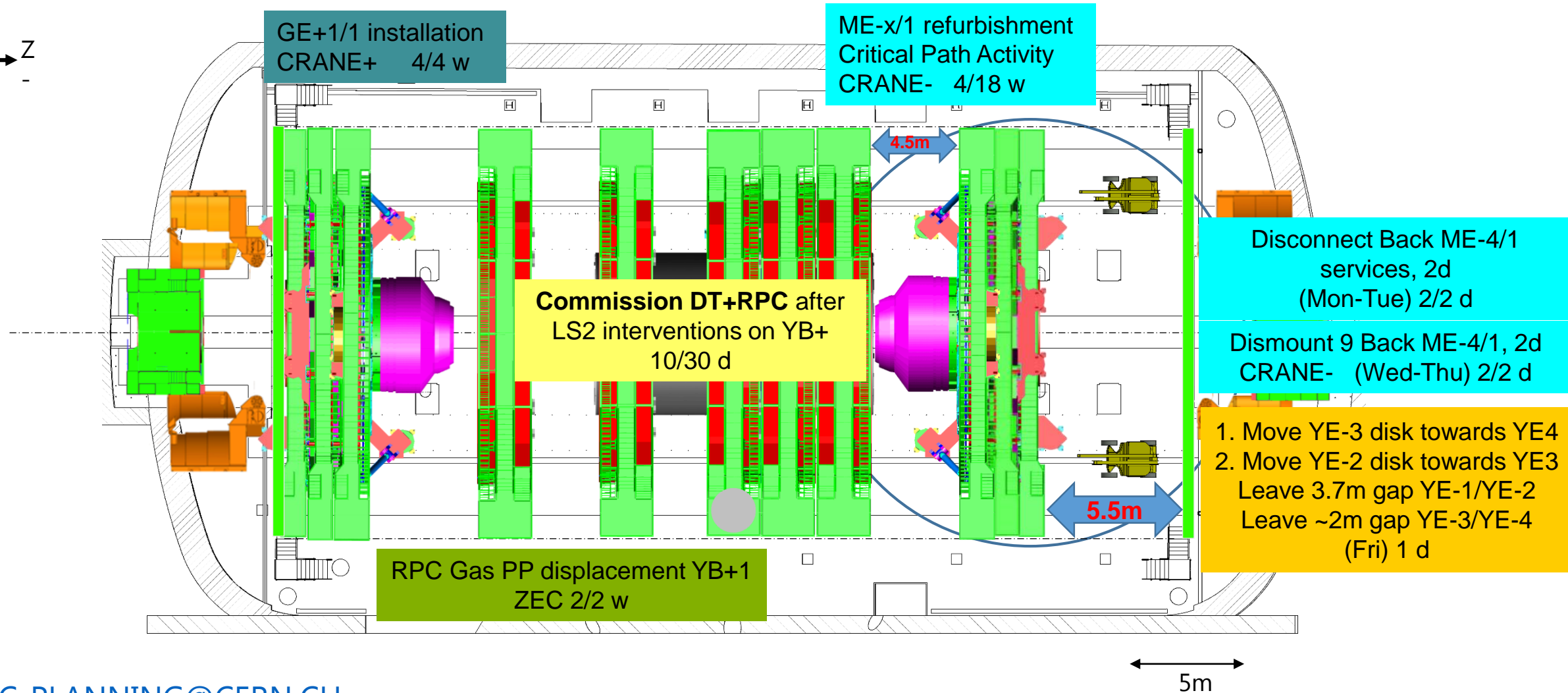
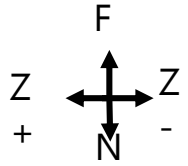





Crane

Cryo.	<span style="background-color: green; color: white;">█</span>	EL power	<span style="background-color: green; color: white;">█</span>	Water cool.	<span style="background-color: green; color: white;">█</span>	Database	<span style="background-color: green; color: white;">█</span>
IT	<span style="background-color: green; color: white;">█</span>	Magnet	<span style="background-color: red; color: white;">█</span>	C6F14	<span style="background-color: green; color: white;">█</span>	Gas	<span style="background-color: green; color: white;">█</span>
SL. 0	<span style="background-color: teal; color: white;">█</span> GEM	<span style="background-color: blue; color: white;">█</span> ECAL	<span style="background-color: green; color: white;">█</span> ZEC	<span style="background-color: yellow; color: black;">█</span> DT+ RB	<span style="background-color: grey; color: white;">█</span> Survey	<span style="background-color: pink; color: black;">█</span> TE-VSC	<span style="background-color: brown; color: white;">█</span> GS Dept
CP. 0	<span style="background-color: olive; color: white;">█</span> TOTEM	<span style="background-color: yellow; color: black;">█</span> CMX	<span style="background-color: cyan; color: black;">█</span> CSC RE	<span style="background-color: purple; color: white;">█</span> TK PIX	<span style="background-color: magenta; color: black;">█</span> HCAL	<span style="background-color: orange; color: black;">█</span> EN Dept	<span style="border: 2px solid black; padding: 2px;">RP</span>

PX56 Plug  
CLOSED

TX54 Plug  
CLOSED

2020

March – Week 11

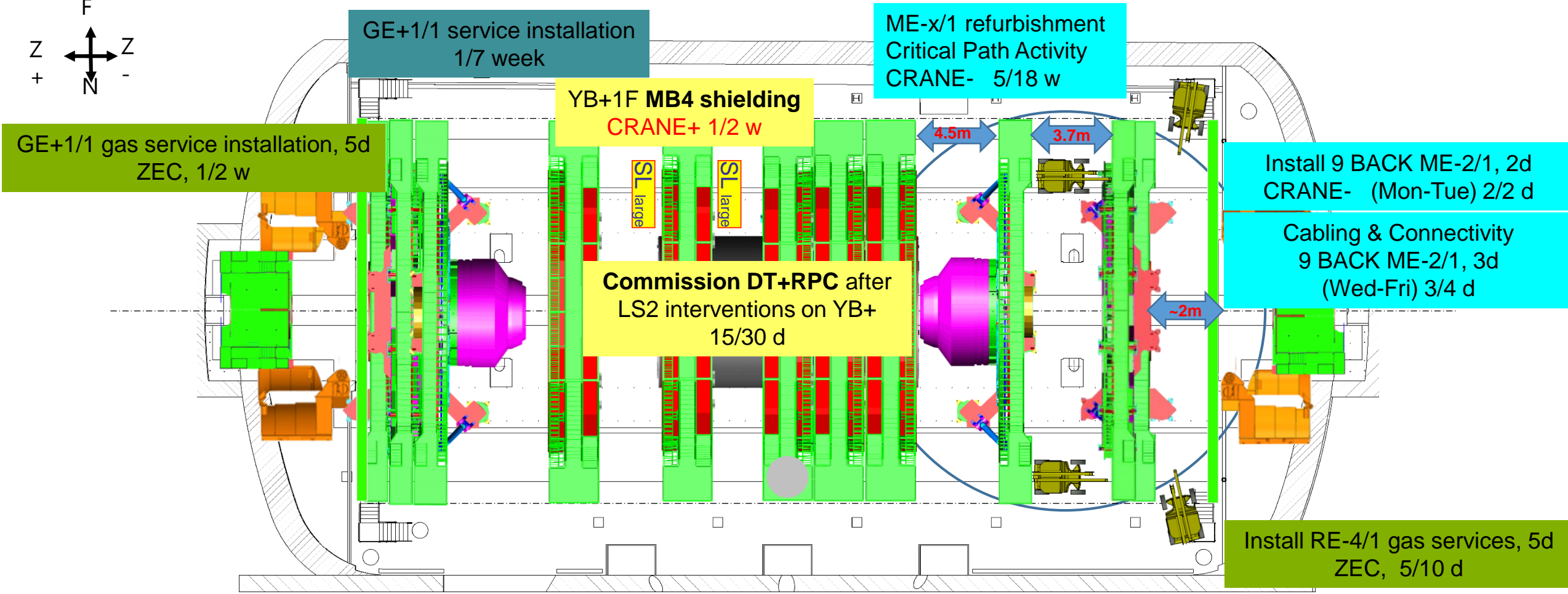
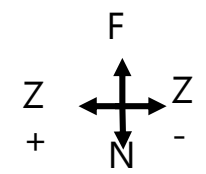

5m



Cryo.	█	EL power	█	Water cool.	█	Database	█								
IT	█	Magnet	█	C6F14	█	Gas	█								
SL.	0	GEM	█	ECAL	█	ZEC	█	DT+ RB	█	Survey	█	TE-VSC	█	GS Dept	█
CP.	0	TOTEM	█	CMX	█	CSC RE	█	TK PIX	█	HCAL	█	EN Dept	█	<b>RP</b>	█

PX56 Plug CLOSED	2020
TX54 Plug CLOSED	March – Week 12

Crane

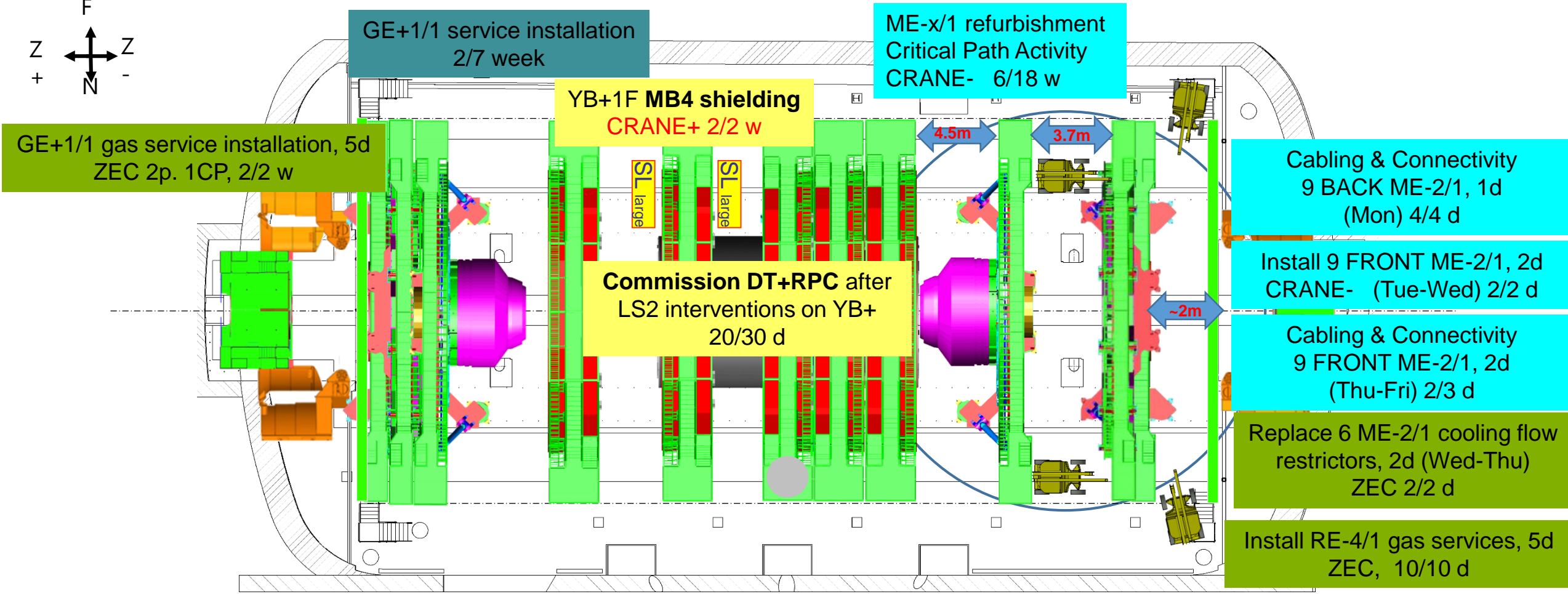
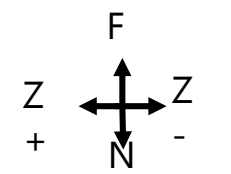

GE+1/1 gas service installation, 5d  
ZEC 2p. 1CP, 2/2 w

GE+1/1 service installation  
2/7 week

YB+1F MB4 shielding  
CRANE+ 2/2 w

ME-x/1 refurbishment  
Critical Path Activity  
CRANE- 6/18 w

Commission DT+RPC after  
LS2 interventions on YB+  
20/30 d

Cabling & Connectivity  
9 BACK ME-2/1, 1d  
(Mon) 4/4 d

Install 9 FRONT ME-2/1, 2d  
CRANE- (Tue-Wed) 2/2 d

Cabling & Connectivity  
9 FRONT ME-2/1, 2d  
(Thu-Fri) 2/3 d

Replace 6 ME-2/1 cooling flow  
restrictors, 2d (Wed-Thu)  
ZEC 2/2 d

Install RE-4/1 gas services, 5d  
ZEC, 10/10 d

5m



Cryo.	<span style="background-color: green; color: green;">■</span>	EL power	<span style="background-color: green; color: green;">■</span>	Water cool.	<span style="background-color: green; color: green;">■</span>	Database	<span style="background-color: green; color: green;">■</span>
IT	<span style="background-color: green; color: green;">■</span>	Magnet	<span style="background-color: red; color: red;">■</span>	C6F14	<span style="background-color: green; color: green;">■</span>	Gas	<span style="background-color: green; color: green;">■</span>
SL. 0	<span style="background-color: teal; color: white;">GEM</span>	<span style="background-color: blue; color: white;">ECAL</span>	<span style="background-color: green; color: white;">ZEC</span>	<span style="background-color: yellow; color: black;">DT+ RB</span>	<span style="background-color: grey; color: white;">Survey</span>	<span style="background-color: pink; color: black;">TE-VSC</span>	<span style="background-color: brown; color: white;">GS Dept</span>
CP. 0	<span style="background-color: olive; color: white;">TOTEM</span>	<span style="background-color: yellow; color: black;">CMX</span>	<span style="background-color: cyan; color: black;">CSC RE</span>	<span style="background-color: purple; color: white;">TK PIX</span>	<span style="background-color: magenta; color: black;">HCAL</span>	<span style="background-color: orange; color: black;">EN Dept</span>	<span style="border: 2px solid black; padding: 2px;"><b>RP</b></span>

PX56 Plug CLOSED	2020
TX54 Plug CLOSED	March – Week 13

Crane

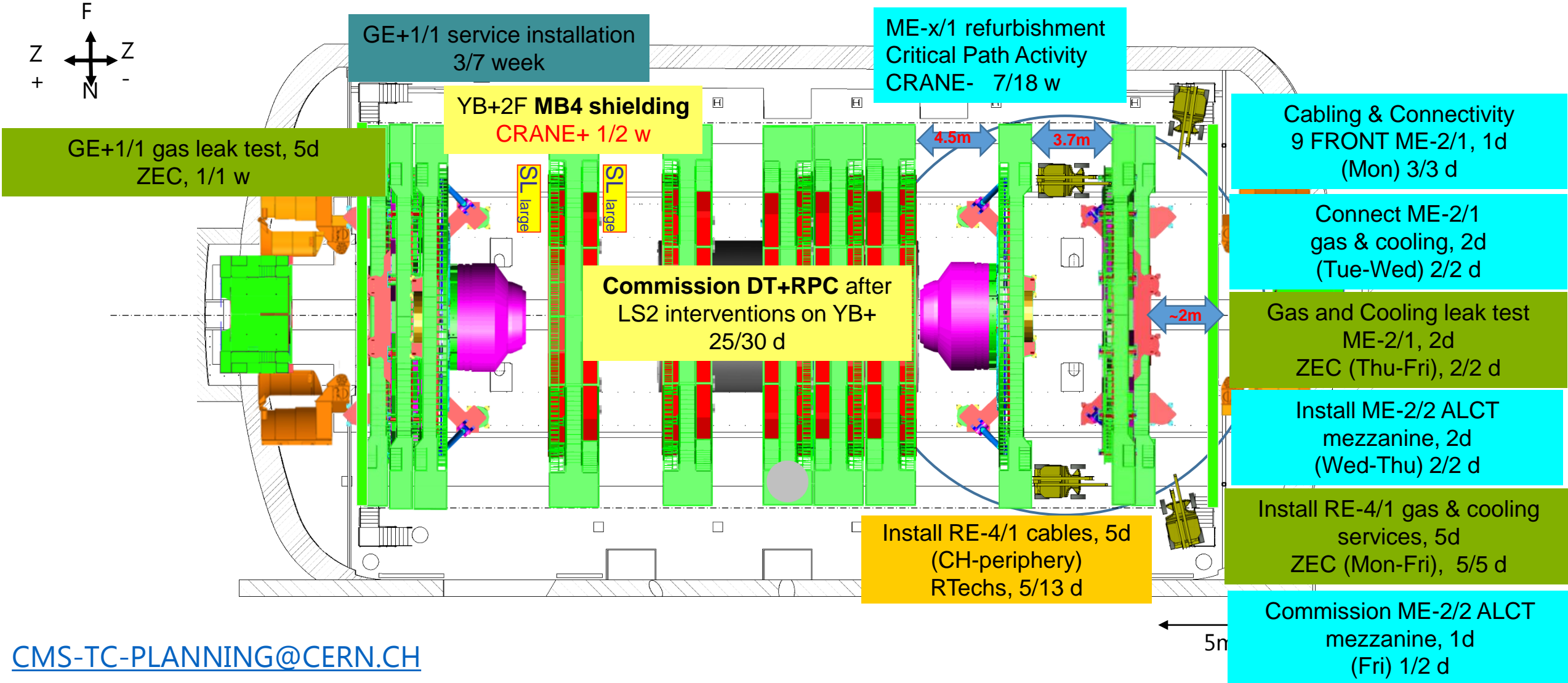
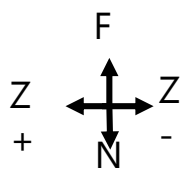



Crane

Cryo.		EL power		Water cool.		Database	
IT		Magnet		C6F14		Gas	
SL. 0		ECAL		ZEC		DT+ RB	
CP. 0		TOTEM		CSC RE		TK PIX	
				Survey		TE-VSC	
				HCAL		EN Dept	
						<b>RP</b>	

PX56 Plug CLOSED

2020

TX54 Plug CLOSED

March – Week 14

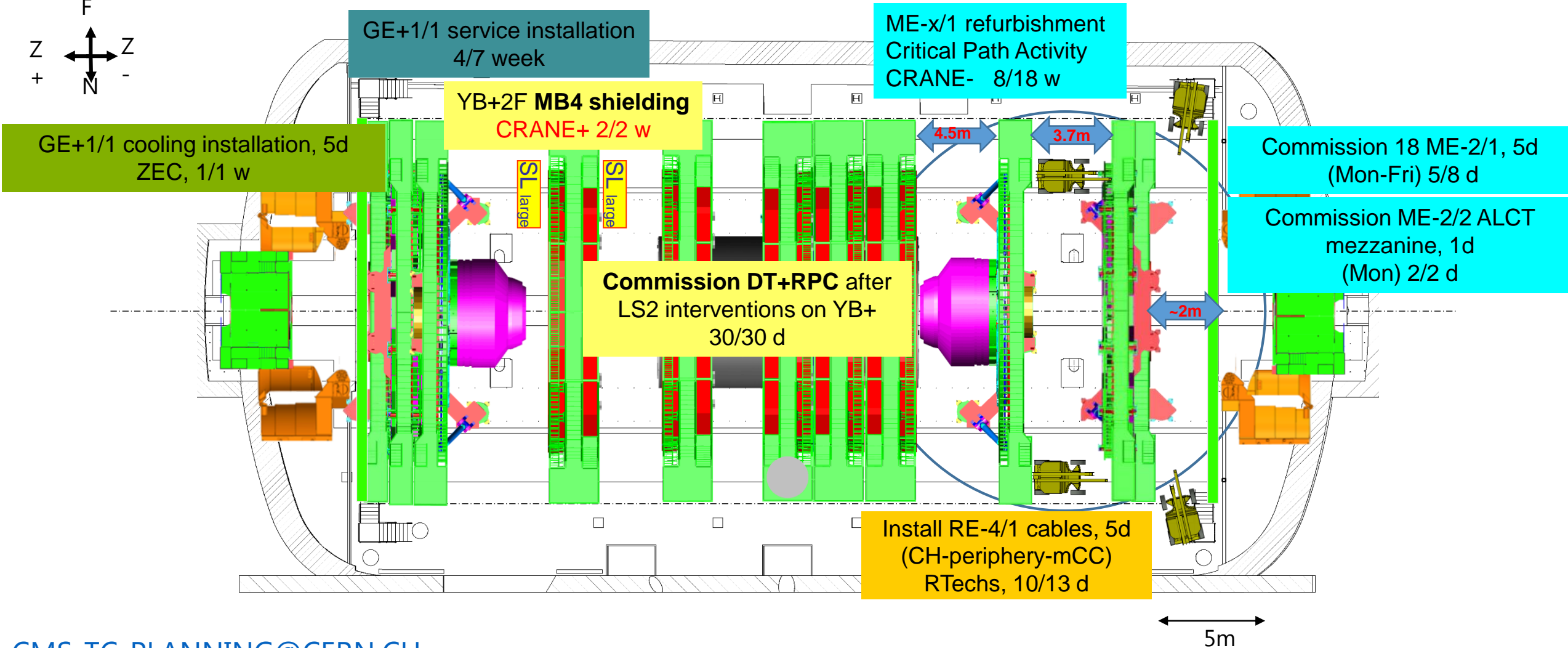
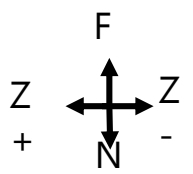





Cryo.	<span style="color: green;">■</span>	EL power	<span style="color: green;">■</span>	Water cool.	<span style="color: green;">■</span>	Database	<span style="color: green;">■</span>
IT	<span style="color: green;">■</span>	Magnet	<span style="color: red;">■</span>	C6F14	<span style="color: green;">■</span>	Gas	<span style="color: green;">■</span>
SL. 0	GEM	ECAL	ZEC	DT+ RB	Survey	TE-VSC	GS Dept
CP. 0	TOTEM	CMX	CSC RE	TK PIX	HCAL	EN Dept	<b>RP</b>

PX56 Plug CLOSED	2020
TX54 Plug CLOSED	April – Week 15

Crane

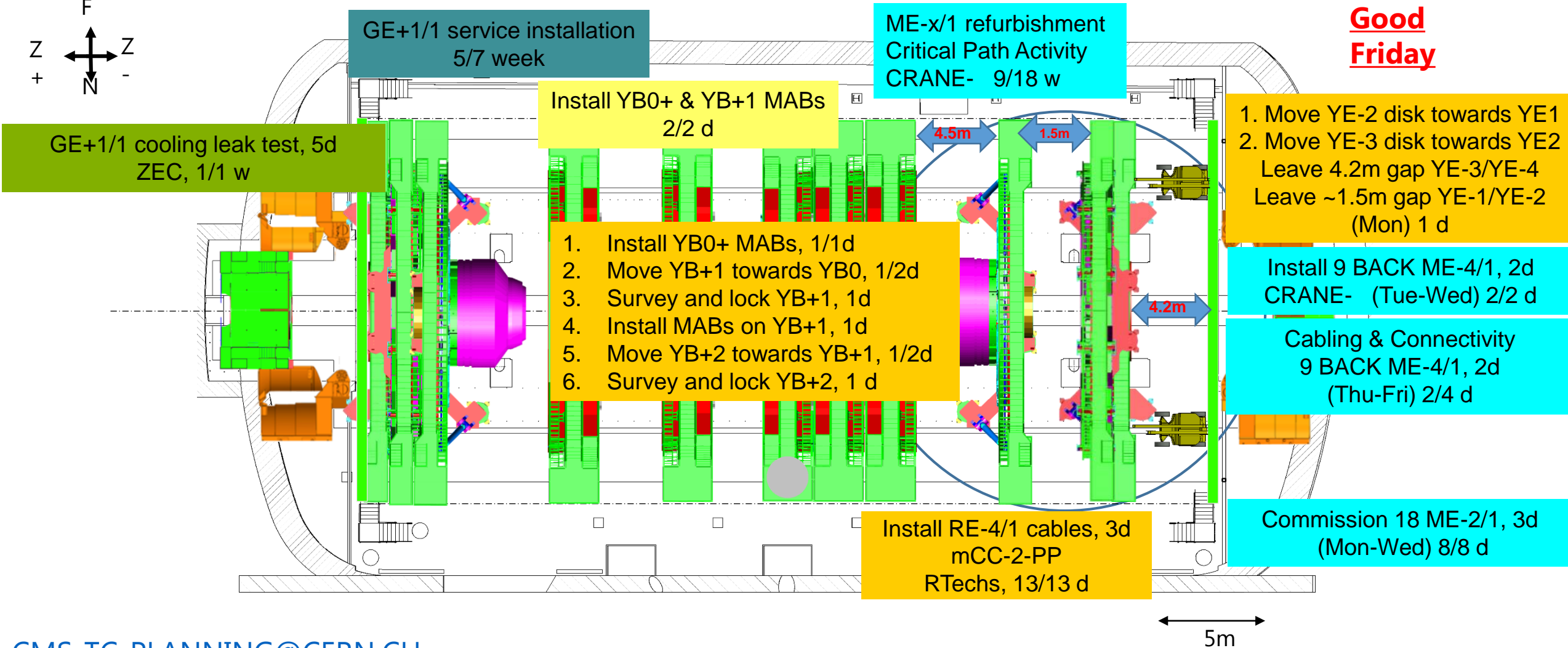
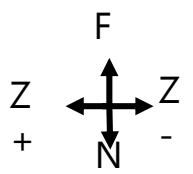

**Good Friday**





Cryo.	█	EL power	█	Water cool.	█	Database	█								
IT	█	Magnet	█	C6F14	█	Gas	█								
SL.	0	GEM	█	ECAL	█	ZEC	█	DT+ RB	█	Survey	█	TE-VSC	█	GS Dept	█
CP.	0	TOTEM	█	CMX	█	CSC RE	█	TK PIX	█	HCAL	█	EN Dept	█	<b>RP</b>	█

PX56 Plug CLOSED

2020

TX54 Plug CLOSED

April – Week 16

Crane

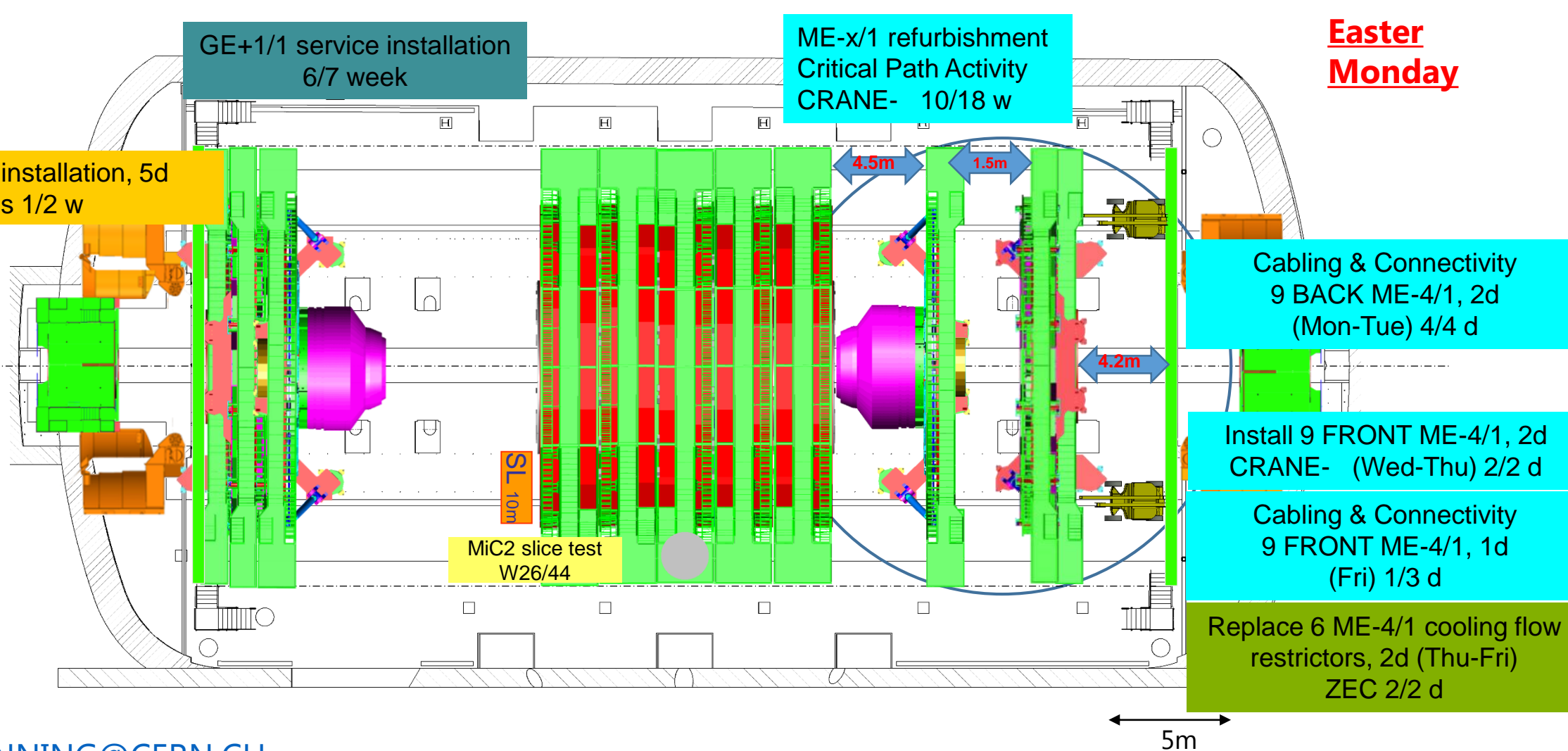
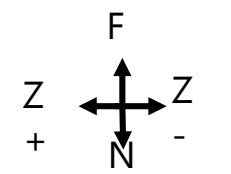

**Easter Monday**



Crane

Cryo.	<span style="background-color: green; color: green;">█</span>	EL power	<span style="background-color: green; color: green;">█</span>	Water cool.	<span style="background-color: green; color: green;">█</span>	Database	<span style="background-color: green; color: green;">█</span>	
IT	<span style="background-color: green; color: green;">█</span>	Magnet	<span style="background-color: red; color: red;">█</span>	C6F14	<span style="background-color: green; color: green;">█</span>	Gas	<span style="background-color: green; color: green;">█</span>	
SL.	0	GEM	ECAL	ZEC	DT+ RB	Survey	TE-VSC	GS Dept
CP.	0	TOTEM	CMX	CSC RE	TK PIX	HCAL	EN Dept	<b>RP</b>

PX56 Plug  
CLOSED

TX54 Plug  
CLOSED

2020

April – Week 17

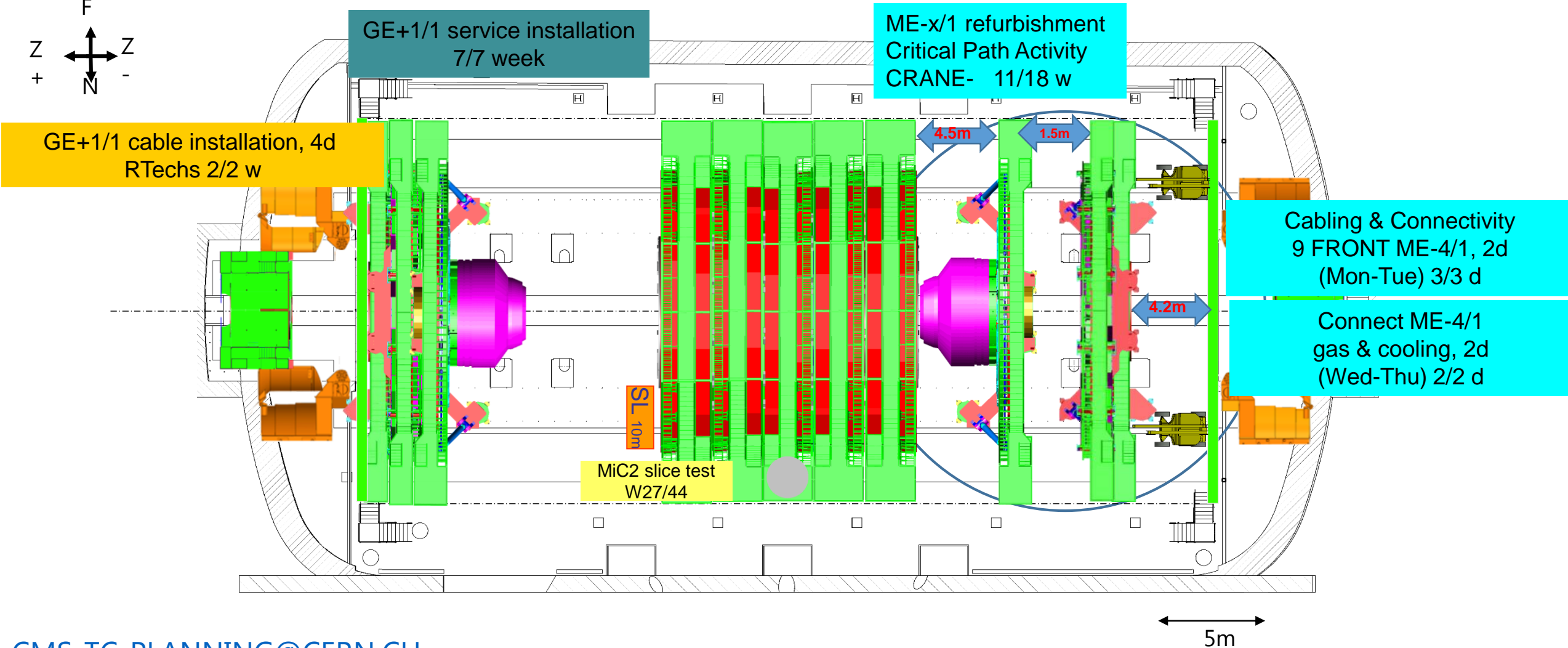
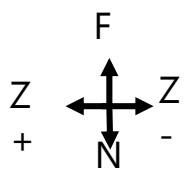



Crane

Cryo.	█	EL power	█	Water cool.	█	Database	█
IT	█	Magnet	█	C6F14	█	Gas	█
SL. 0	GEM	ECAL	ZEC	DT+ RB	Survey	TE-VSC	GS Dept
CP. 0	TOTEM	CMX	CSC RE	TK PIX	HCAL	EN Dept	<b>RP</b>

PX56 Plug CLOSED

2020

TX54 Plug CLOSED

April – Week 18

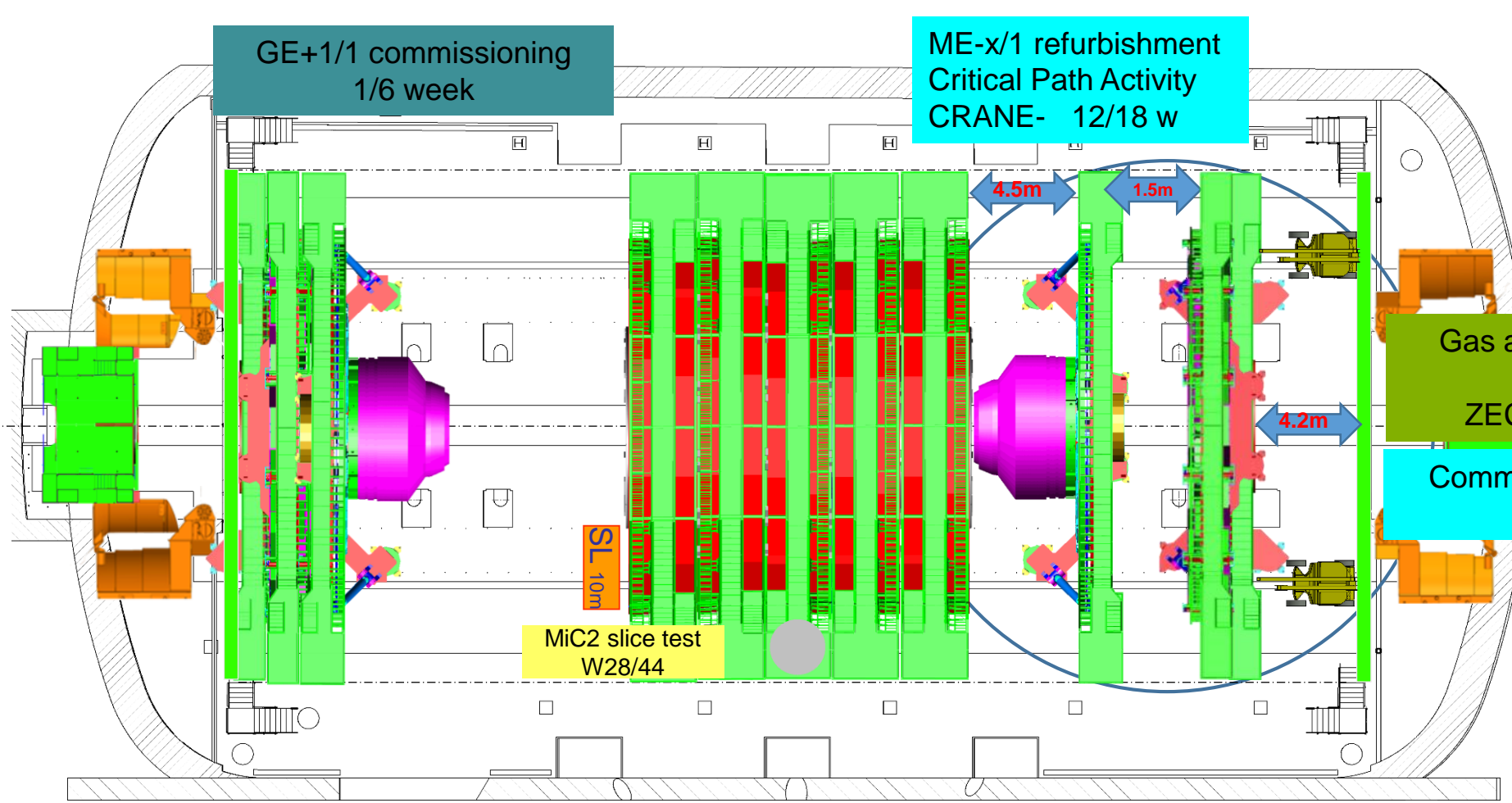
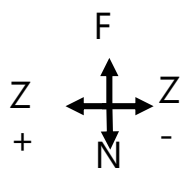



Crane

Cryo.	<span style="background-color: green; width: 15px; height: 15px; display: inline-block;"></span>	EL power	<span style="background-color: green; width: 15px; height: 15px; display: inline-block;"></span>	Water cool.	<span style="background-color: green; width: 15px; height: 15px; display: inline-block;"></span>	Database	<span style="background-color: green; width: 15px; height: 15px; display: inline-block;"></span>
IT	<span style="background-color: green; width: 15px; height: 15px; display: inline-block;"></span>	Magnet	<span style="background-color: red; width: 15px; height: 15px; display: inline-block;"></span>	C6F14	<span style="background-color: green; width: 15px; height: 15px; display: inline-block;"></span>	Gas	<span style="background-color: green; width: 15px; height: 15px; display: inline-block;"></span>
SL. 0	<span style="background-color: teal; width: 15px; height: 15px; display: inline-block;"></span> GEM	<span style="background-color: blue; width: 15px; height: 15px; display: inline-block;"></span> ECAL	<span style="background-color: green; width: 15px; height: 15px; display: inline-block;"></span> ZEC	<span style="background-color: yellow; width: 15px; height: 15px; display: inline-block;"></span> DT+ RB	<span style="background-color: grey; width: 15px; height: 15px; display: inline-block;"></span> Survey	<span style="background-color: pink; width: 15px; height: 15px; display: inline-block;"></span> TE-VSC	<span style="background-color: brown; width: 15px; height: 15px; display: inline-block;"></span> GS Dept
CP. 0	<span style="background-color: olive; width: 15px; height: 15px; display: inline-block;"></span> TOTEM	<span style="background-color: yellow; width: 15px; height: 15px; display: inline-block;"></span> CMX	<span style="background-color: cyan; width: 15px; height: 15px; display: inline-block;"></span> CSC RE	<span style="background-color: purple; width: 15px; height: 15px; display: inline-block;"></span> TK PIX	<span style="background-color: magenta; width: 15px; height: 15px; display: inline-block;"></span> HCAL	<span style="background-color: orange; width: 15px; height: 15px; display: inline-block;"></span> EN Dept	<span style="border: 2px solid black; padding: 2px;">RP</span>

PX56 Plug CLOSED	2020
TX54 Plug CLOSED	May – Week 19

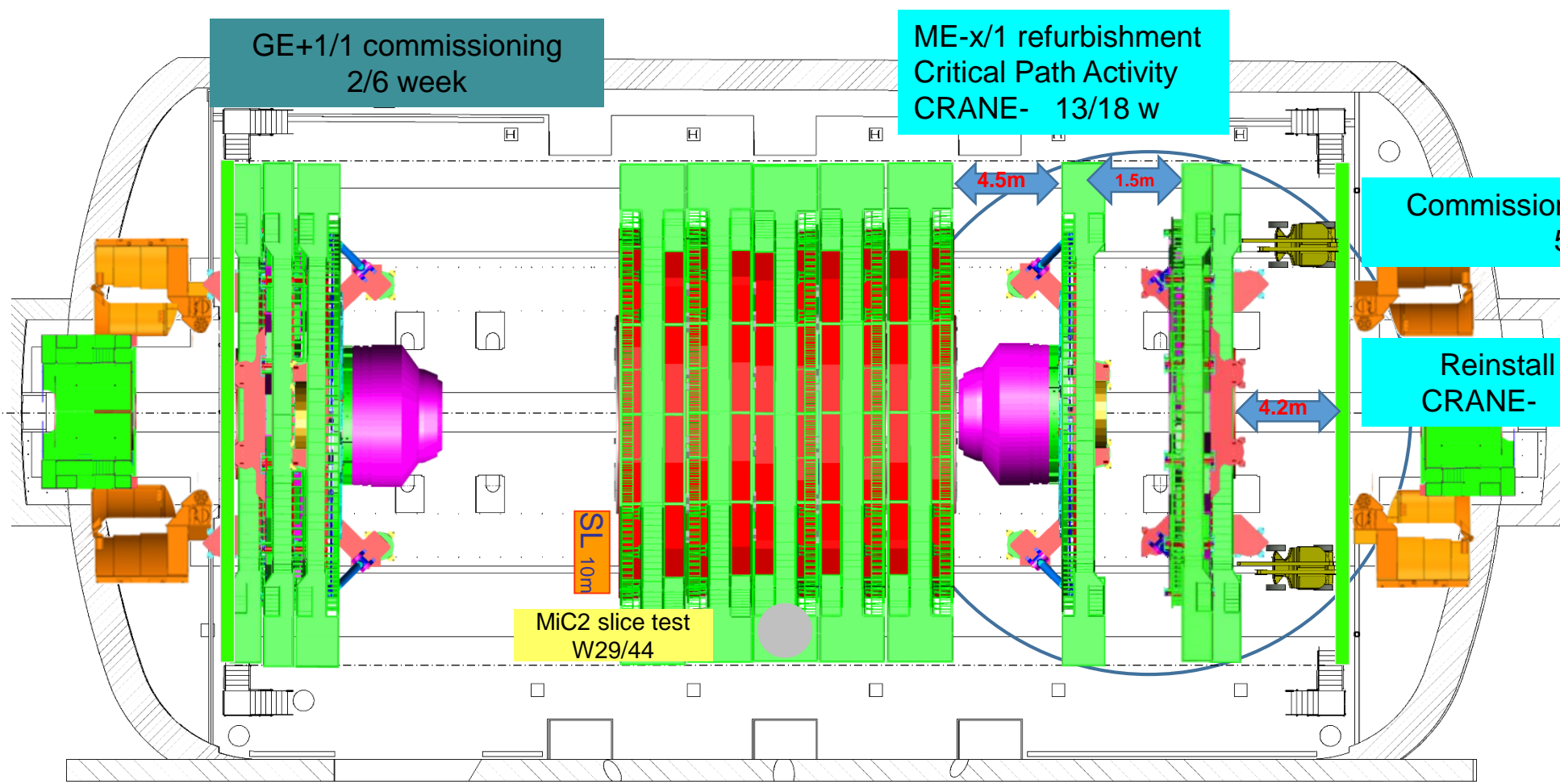
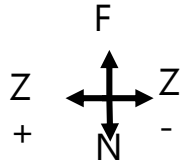

GE+1/1 commissioning  
2/6 week

ME-x/1 refurbishment  
Critical Path Activity  
CRANE- 13/18 w

Commission 18 ME-4/1, 3d  
5/8 d

Reinstall RE-4 SM, 2d  
CRANE- (Thu-Fri) 2/6 d

SL 10m  
MiC2 slice test  
W29/44

5m





Crane

Cryo.	█	EL power	█	Water cool.	█	Database	█								
IT	█	Magnet	█	C6F14	█	Gas	█								
SL.	0	GEM	█	ECAL	█	ZEC	█	DT+ RB	█	Survey	█	TE-VSC	█	GS Dept	█
CP.	0	TOTEM	█	CMX	█	CSC RE	█	TK PIX	█	HCAL	█	EN Dept	█	<b>RP</b>	█

PX56 Plug CLOSED
TX54 Plug CLOSED

2020
May – Week 20

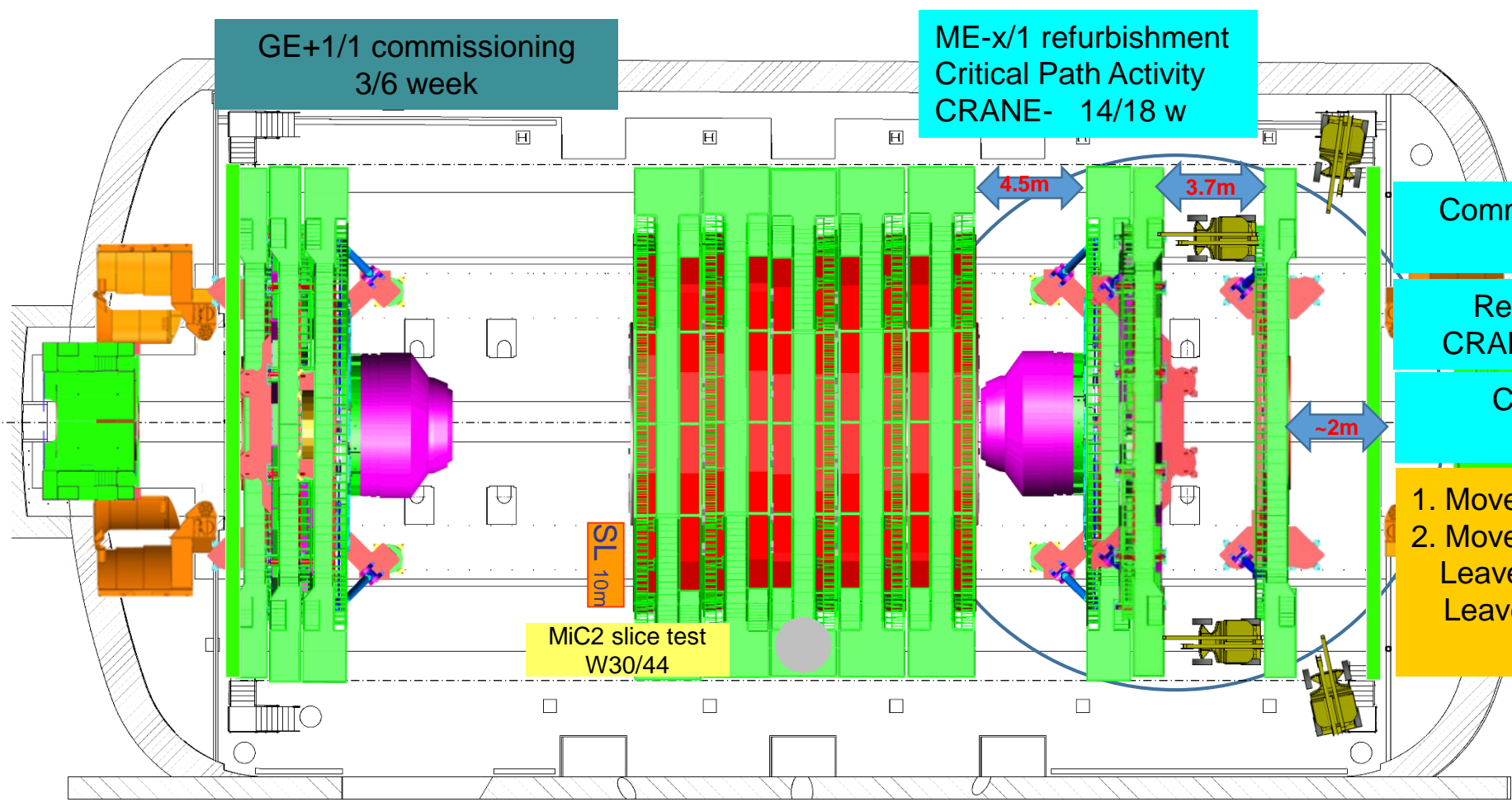
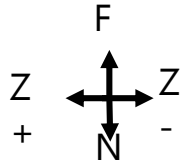

- Commission 18 ME-4/1, 3d  
8/8 d
- Reinstall RE-4 SM, 4d  
CRANE- (Mon-Thu) 6/6 d
- Cable RE-4 SM, 3d  
(Tue-Thu) 3/6 d
- 1. Move YE-2 disk towards YE1  
2. Move YE-3 disk towards YE4  
Leave 3.7m gap YE-2/YE-3  
Leave ~2m gap YE-3/YE-4  
(Fri) 1 d

5m





Cryo.	<span style="background-color: green; color: green;">■</span>	EL power	<span style="background-color: green; color: green;">■</span>	Water cool.	<span style="background-color: green; color: green;">■</span>	Database	<span style="background-color: green; color: green;">■</span>
IT	<span style="background-color: green; color: green;">■</span>	Magnet	<span style="background-color: red; color: red;">■</span>	C6F14	<span style="background-color: green; color: green;">■</span>	Gas	<span style="background-color: green; color: green;">■</span>
SL. 0	<span style="background-color: teal; color: white;">GEM</span>	<span style="background-color: blue; color: white;">ECAL</span>	<span style="background-color: green; color: white;">ZEC</span>	<span style="background-color: yellow; color: black;">DT+ RB</span>	<span style="background-color: grey; color: white;">Survey</span>	<span style="background-color: pink; color: black;">TE-VSC</span>	<span style="background-color: brown; color: white;">GS Dept</span>
CP. 0	<span style="background-color: olive; color: white;">TOTEM</span>	<span style="background-color: yellow; color: black;">CMX</span>	<span style="background-color: cyan; color: black;">CSC RE</span>	<span style="background-color: purple; color: white;">TK PIX</span>	<span style="background-color: magenta; color: black;">HCAL</span>	<span style="background-color: orange; color: black;">EN Dept</span>	<span style="border: 2px solid black; padding: 2px;"><b>RP</b></span>

PX56 Plug CLOSED	2020
TX54 Plug CLOSED	May – Week 21

Crane

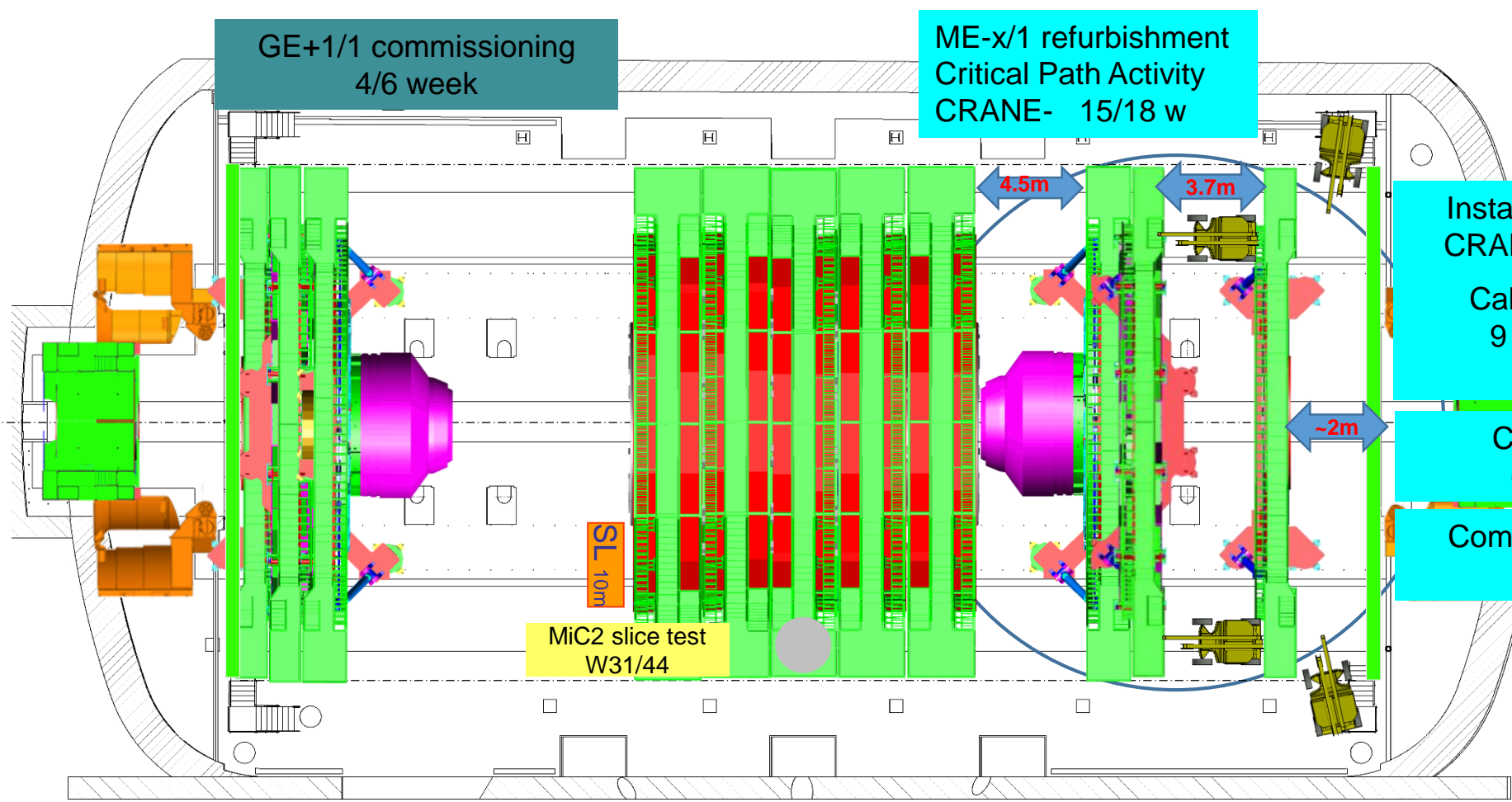
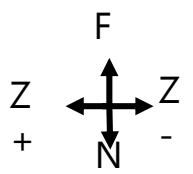

- Install 9 BACK ME-3/1, 2d  
CRANE- (Mon-Tue) 2/2 d
- Cabling & Connectivity  
9 BACK ME-3/1, 3d  
(Wed-Fri) 3/4 d
- Cable RE-4 SM, 3d  
(Mon-Wed) 6/6 d
- Commission RE-4 SM, 2d  
2/8 d



Cryo.	█	EL power	█	Water cool.	█	Database	█
IT	█	Magnet	█	C6F14	█	Gas	█
SL. 0	GEM	ECAL	ZEC	DT+ RB	Survey	TE-VSC	GS Dept
CP. 0	TOTEM	CMX	CSC RE	TK PIX	HCAL	EN Dept	<b>RP</b>

PX56 Plug CLOSED

2020

TX54 Plug CLOSED

May – Week 22

Crane

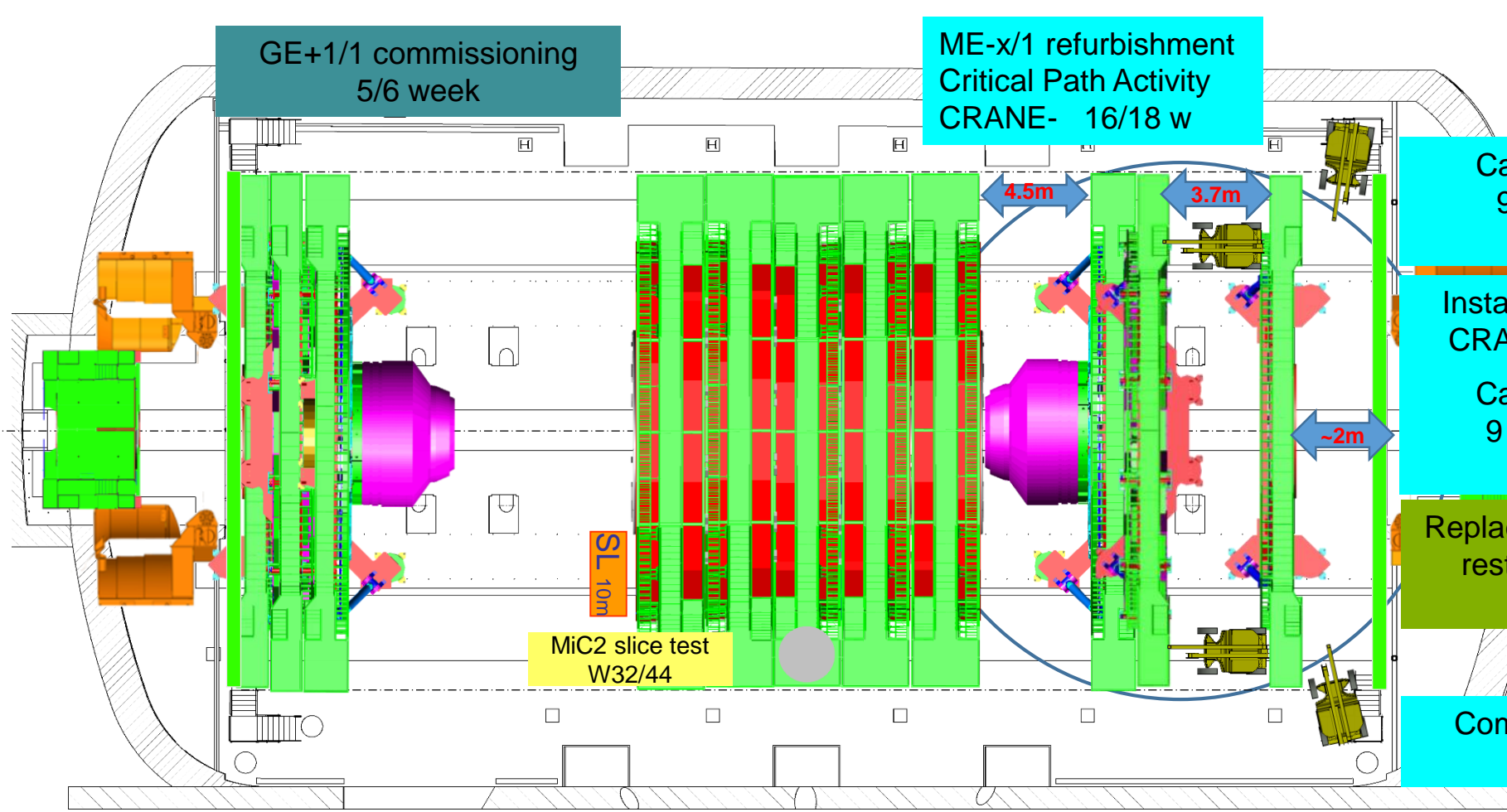
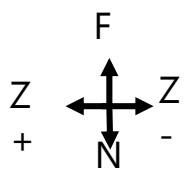

Cabling & Connectivity  
9 BACK ME-3/1, 1d  
(Mon) 4/4 d

Install 9 FRONT ME-3/1, 2d  
CRANE- (Tue-Wed) 2/2 d

Cabling & Connectivity  
9 FRONT ME-3/1, 2d  
(Thu-Fri) 2/3 d

Replace 6 ME-3/1 cooling flow  
restrictors, 2d (Wed-Thu)  
ZEC 2/2 d

Commission RE-4 SM, 5d  
7/8 d

5m



Crane

Cryo.	█	EL power	█	Water cool.	█	Database	█								
IT	█	Magnet	█	C6F14	█	Gas	█								
SL.	0	GEM	█	ECAL	█	ZEC	█	DT+ RB	█	Survey	█	TE-VSC	█	GS Dept	█
CP.	0	TOTEM	█	CMX	█	CSC RE	█	TK PIX	█	HCAL	█	EN Dept	█	<b>RP</b>	█

PX56 Plug CLOSED
TX54 Plug CLOSED

2020
June – Week 23

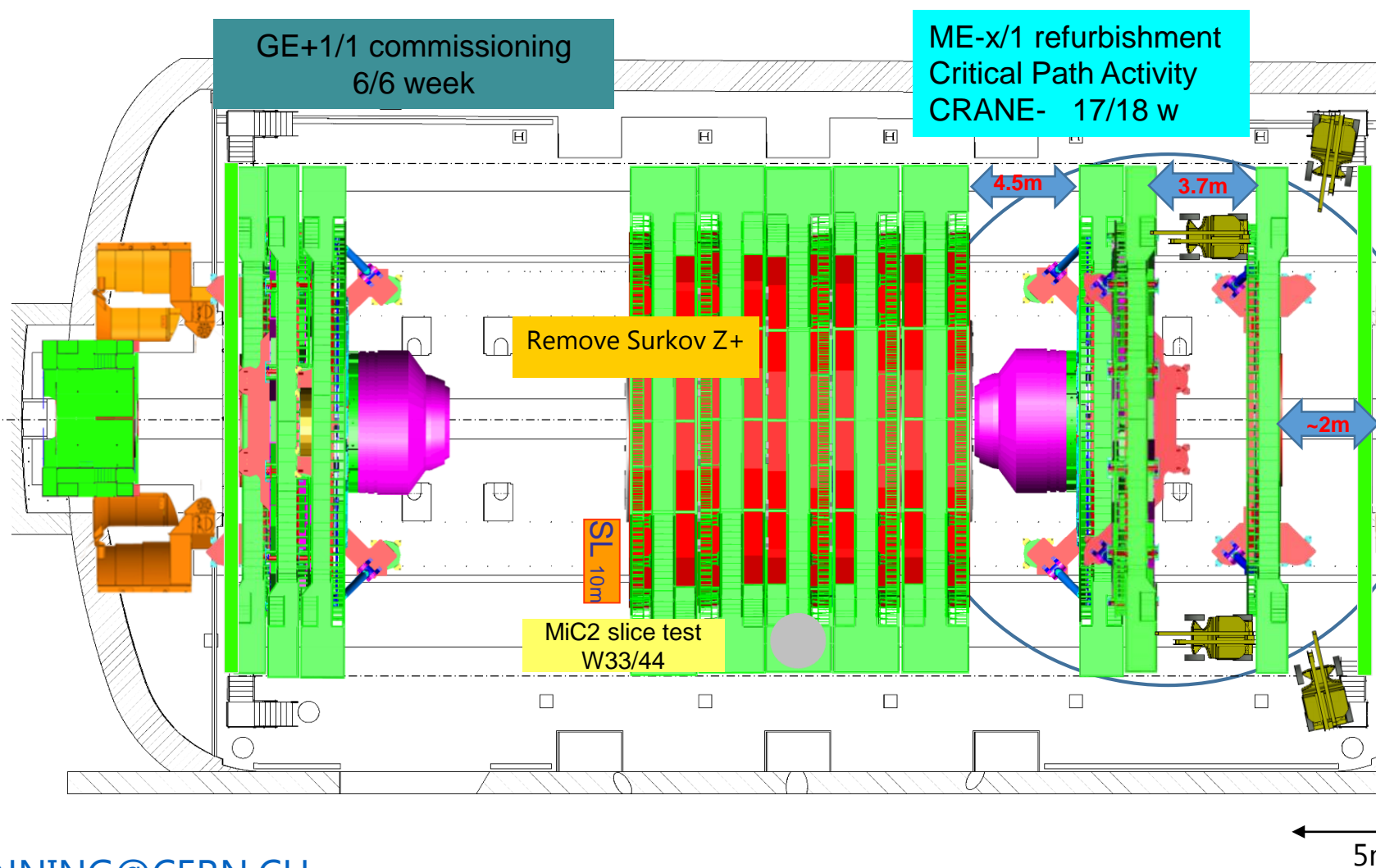
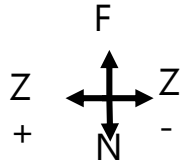

- Cabling & Connectivity  
9 FRONT ME-3/1, 1d  
(Mon) 3/3 d
- Connect ME-3/1  
gas & cooling, 2d  
(Tue-Wed) 2/2 d
- Gas and Cooling leak test  
ME-3/1, 2d  
ZEC (Thu-Fri), 2/2 d
- Commission RE-4 SM, 1d  
8/8 d
- Install ME-3/2 ALCT  
mezzanine, 2d  
(Wed-Thu) 2/2 d
- Commission ME-3/2 ALCT  
mezzanine, 1d  
(Fri) 1/2 d



Crane

Cryo.	█	EL power	█	Water cool.	█	Database	█								
IT	█	Magnet	█	C6F14	█	Gas	█								
SL.	0	GEM	█	ECAL	█	ZEC	█	DT+ RB	█	Survey	█	TE-VSC	█	GS Dept	█
CP.	0	TOTEM	█	CMX	█	CSC RE	█	TK PIX	█	HCAL	█	EN Dept	█	<b>RP</b>	█

PX56 Plug  
CLOSED

TX54 Plug  
CLOSED

2020

June – Week 24

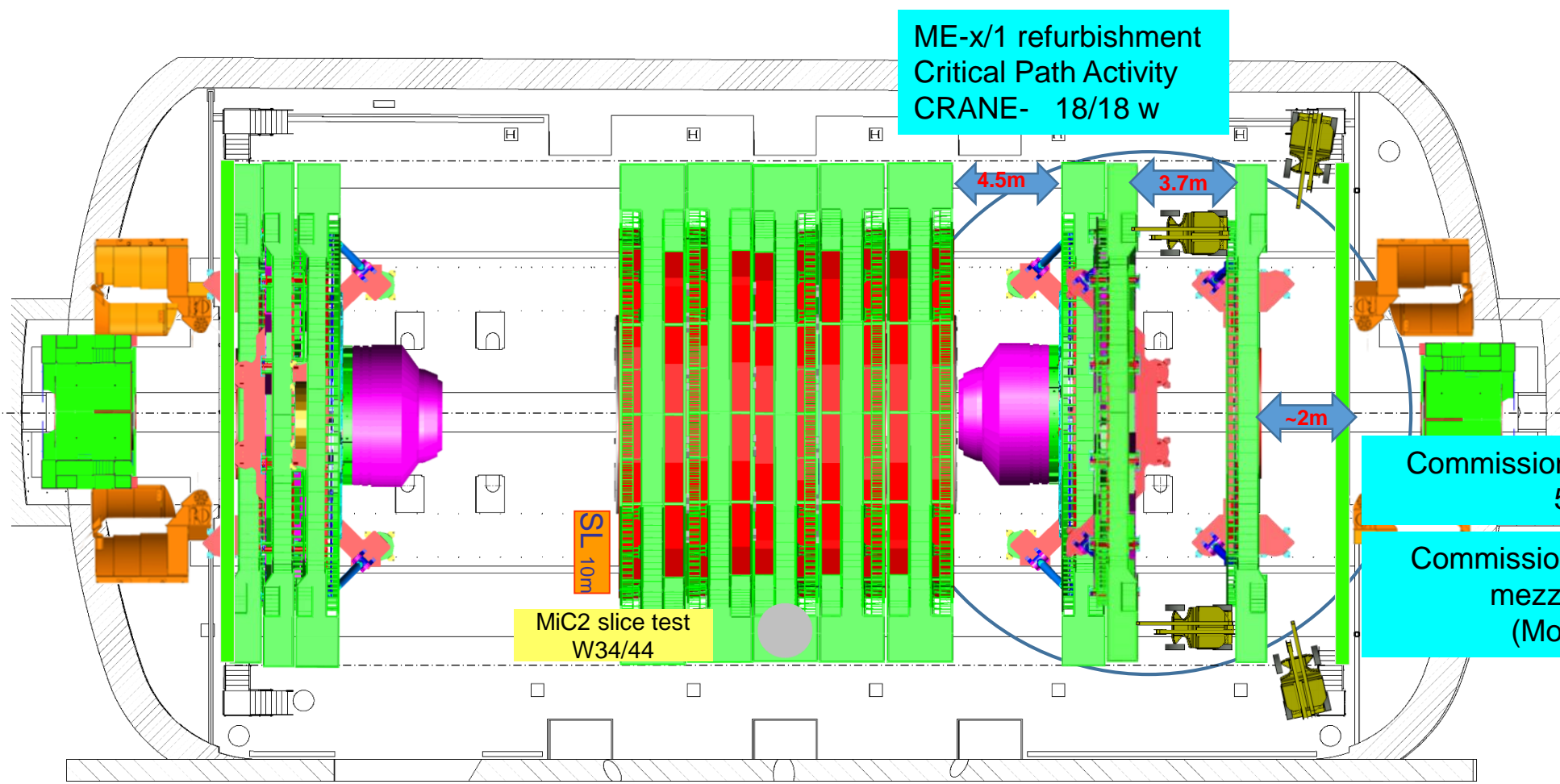
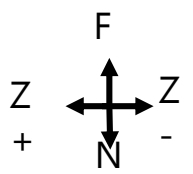

ME-x/1 refurbishment  
Critical Path Activity  
CRANE- 18/18 w

Commission 18 ME-3/1, 5d  
5/8 d

Commission ME-3/2 ALCT  
mezzanine, 1d  
(Mon) 2/2 d

MiC2 slice test  
W34/44

SL 10m

5m





Crane

Cryo.	█	EL power	█	Water cool.	█	Database	█								
IT	█	Magnet	█	C6F14	█	Gas	█								
SL.	0	GEM	█	ECAL	█	ZEC	█	DT+ RB	█	Survey	█	TE-VSC	█	GS Dept	█
CP.	0	TOTEM	█	CMX	█	CSC RE	█	TK PIX	█	HCAL	█	EN Dept	█	<b>RP</b>	█

PX56 Plug  
CLOSED

TX54 Plug  
CLOSED

2020

June – Week 25

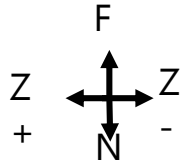

**MUON work is over**

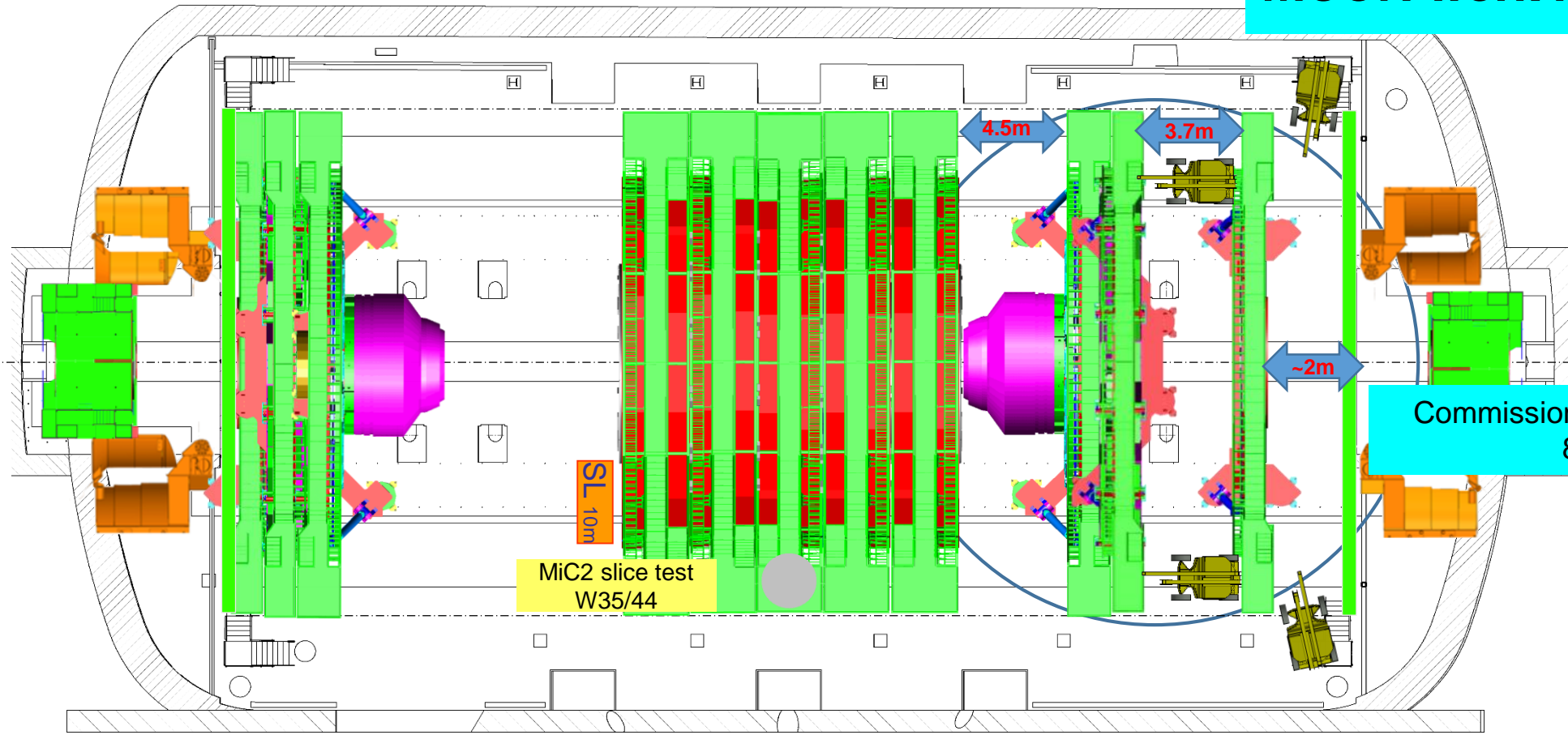

MiC2 slice test  
W35/44

SL 10m

Commission 18 ME-3/1, 3d  
8/8 d

5m





Crane

Cryo.	■	EL power	■	Water cool.	■	Database	■
IT	■	Magnet	■	C6F14	■	Gas	■
SL. 0	GEM	ECAL	ZEC	DT+ RB	Survey	TE-VSC	GS Dept
CP. 0	TOTEM	CMX	CSC RE	TK PIX	HCAL	EN Dept	<b>RP</b>

PX56 Plug  
CLOSED

2020

TX54 Plug  
CLOSED

June - Week 26

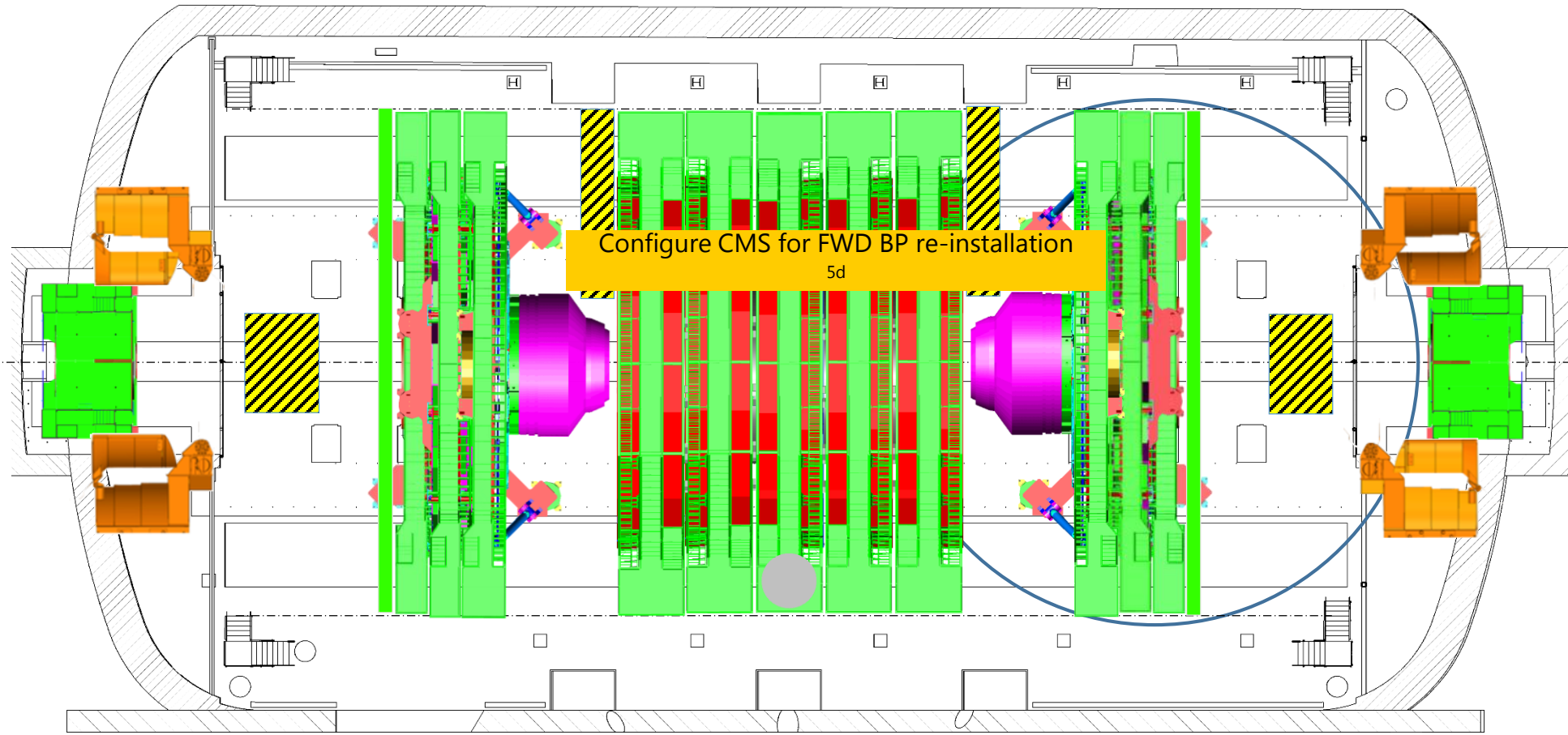
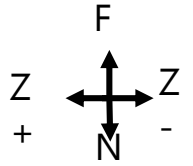

5m



Cryo.	<span style="color: green;">■</span>	EL power	<span style="color: green;">■</span>	Water cool.	<span style="color: green;">■</span>	Database	<span style="color: green;">■</span>
IT	<span style="color: green;">■</span>	Magnet	<span style="color: red;">■</span>	C6F14	<span style="color: green;">■</span>	Gas	<span style="color: green;">■</span>
SL. 0	<span style="background-color: #008080; color: white;">GEM</span>	<span style="background-color: #4169E1; color: white;">ECAL</span>	<span style="background-color: #808000; color: white;">ZEC</span>	<span style="background-color: #FFD700; color: white;">DT+ RB</span>	<span style="background-color: #696969; color: white;">Survey</span>	<span style="background-color: #FFB6C1; color: white;">TE-VSC</span>	<span style="background-color: #8B4513; color: white;">GS Dept</span>
CP. 0	<span style="background-color: #6B8E23; color: white;">TOTEM</span>	<span style="background-color: #FFD700; color: white;">CMX</span>	<span style="background-color: #00FFFF; color: white;">CSC RE</span>	<span style="background-color: #800080; color: white;">TK PIX</span>	<span style="background-color: #FF00FF; color: white;">HCAL</span>	<span style="background-color: #FF8C00; color: white;">EN Dept</span>	<span style="border: 2px solid black; padding: 2px;"><b>RP</b></span>

PX56 Plug  
CLOSED

TX54 Plug  
CLOSED

2020

June - Week 27

Crane

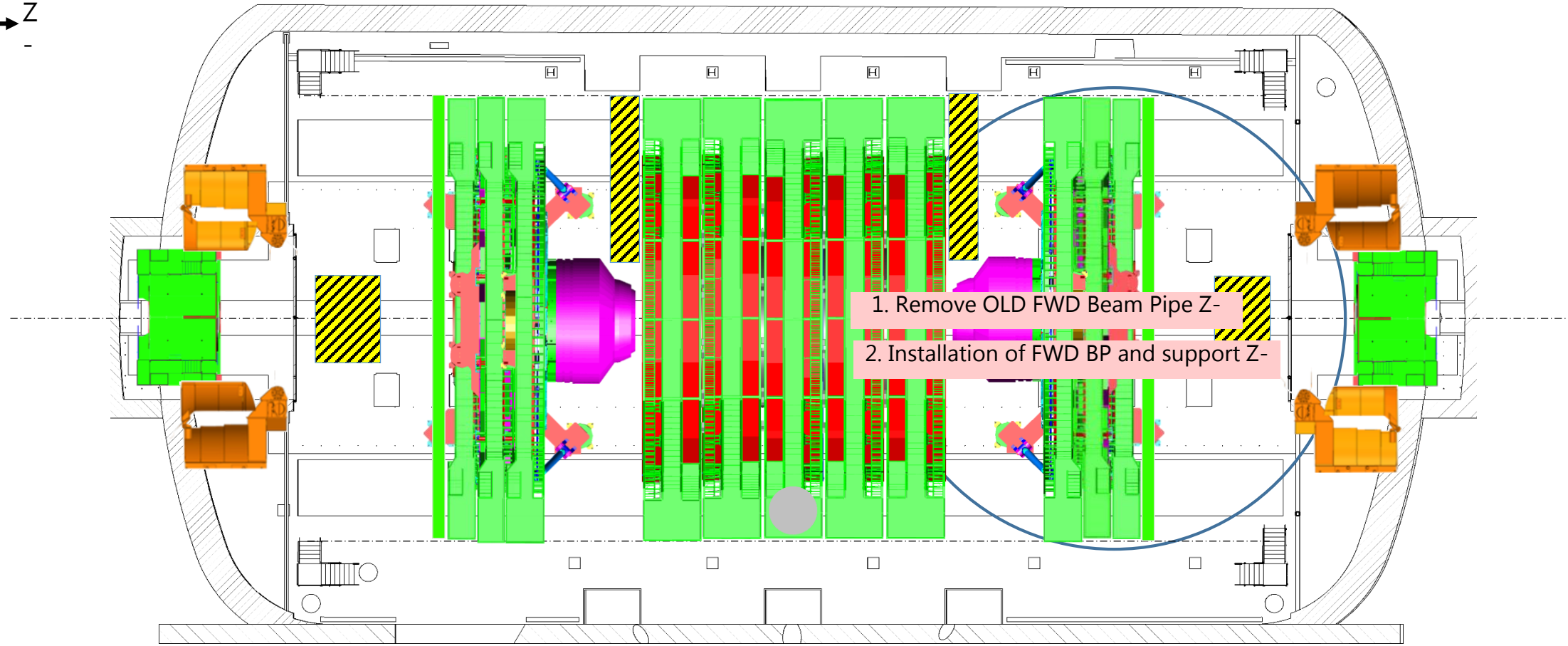
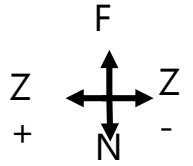

5m



Cryo.	<span style="color: green;">■</span>	EL power	<span style="color: green;">■</span>	Water cool.	<span style="color: green;">■</span>	Database	<span style="color: green;">■</span>
IT	<span style="color: green;">■</span>	Magnet	<span style="color: red;">■</span>	C6F14	<span style="color: green;">■</span>	Gas	<span style="color: green;">■</span>
SL. 0	GEM	ECAL	ZEC	DT+ RB	Survey	TE-VSC	GS Dept
CP. 0	TOTEM	CMX	CSC RE	TK PIX	HCAL	EN Dept	<b>RP</b>

PX56 Plug CLOSED	2020
TX54 Plug CLOSED	July - Week 28

Crane

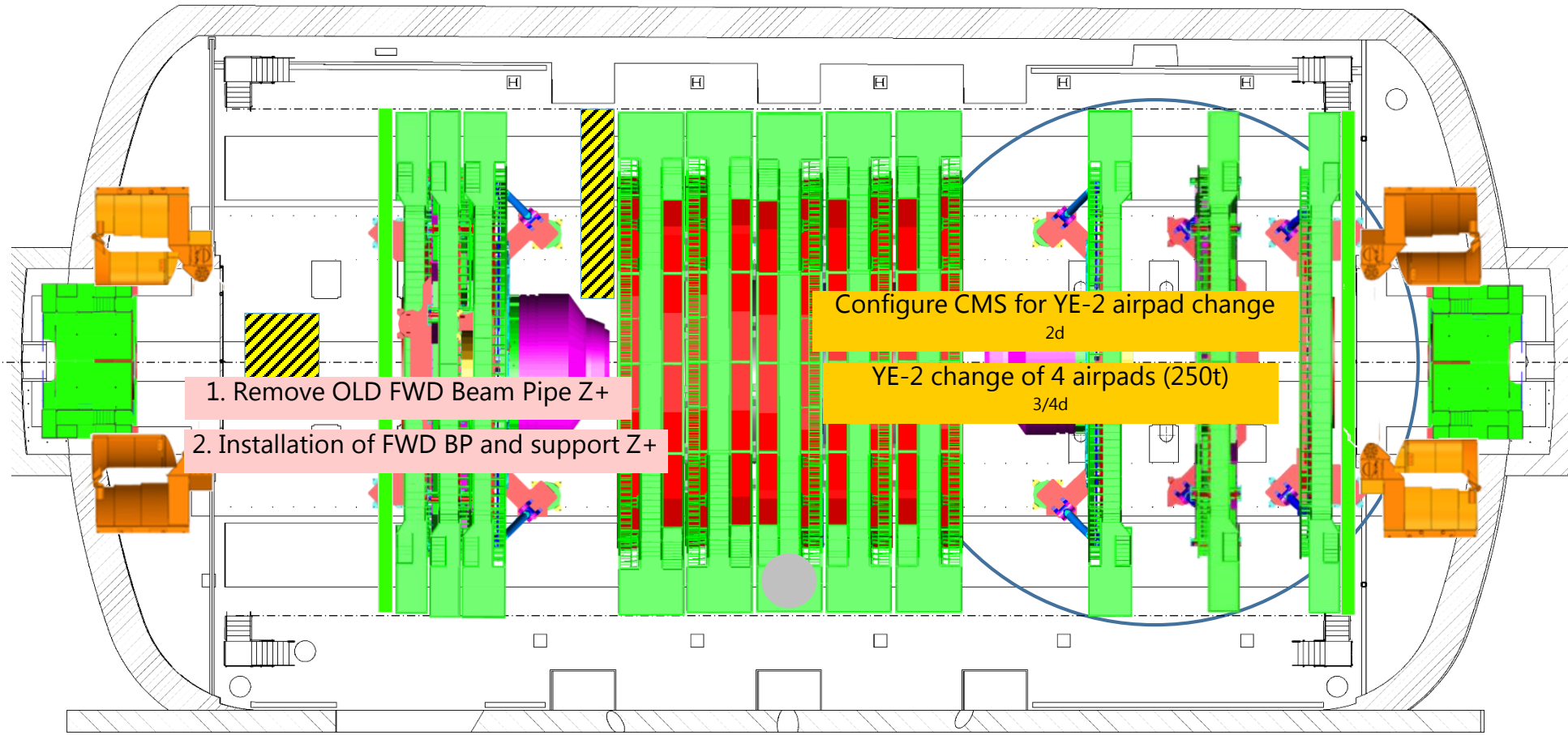
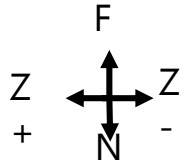

5m



Crane

Cryo.	█	EL power	█	Water cool.	█	Database	█
IT	█	Magnet	█	C6F14	█	Gas	█
SL. 0	GEM	ECAL	ZEC	DT+ RB	Survey	TE-VSC	GS Dept
CP. 0	TOTEM	CMX	CSC RE	TK PIX	HCAL	EN Dept	<b>RP</b>

PX56 Plug CLOSED
TX54 Plug CLOSED

2020
July - Week 29

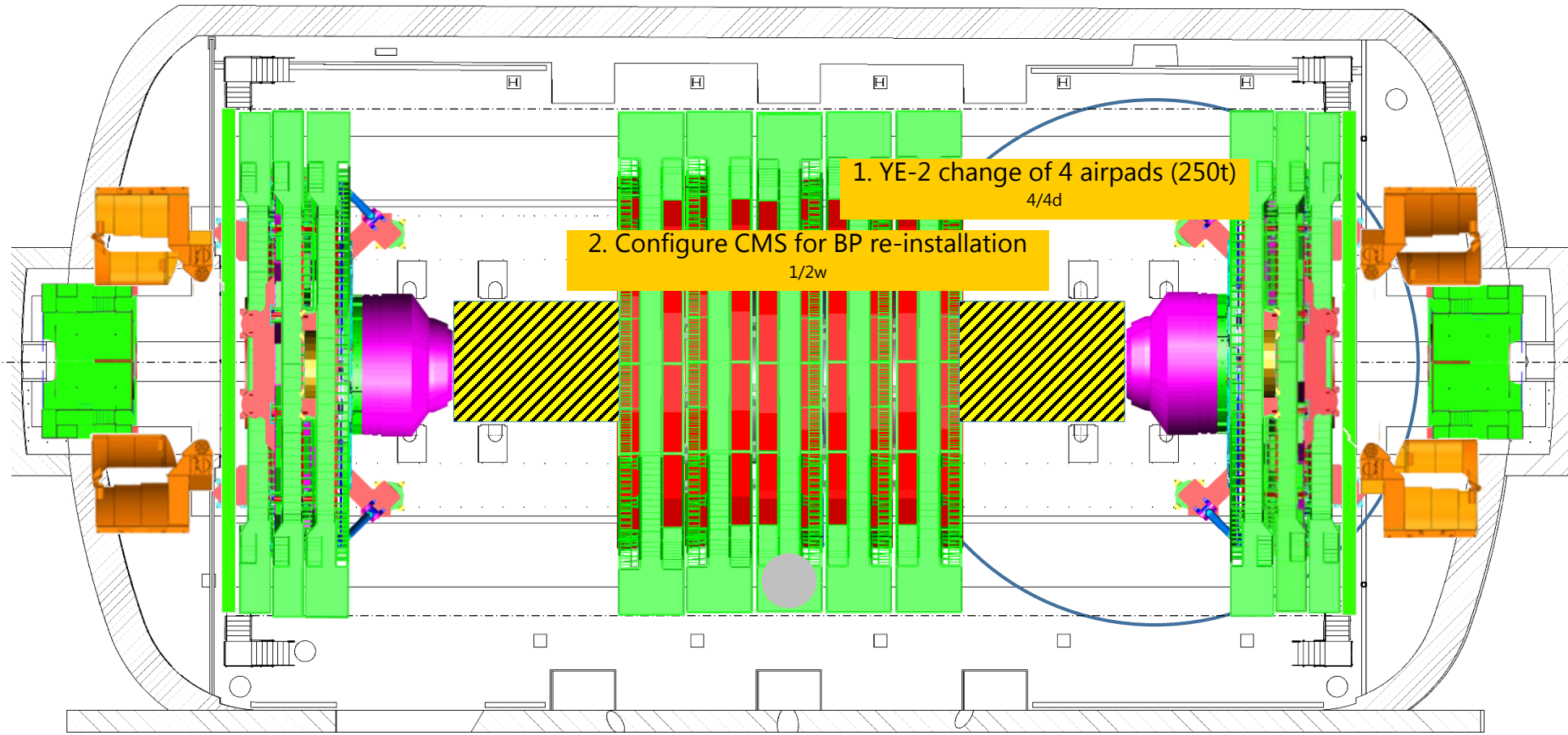
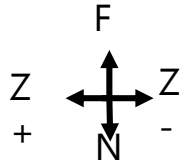

5m



Crane

Cryo.	■	EL power	■	Water cool.	■	Database	■
IT	■	Magnet	■	C6F14	■	Gas	■
SL. 0	GEM	ECAL	ZEC	DT+ RB	Survey	TE-VSC	GS Dept
CP. 0	TOTEM	CMX	CSC RE	TK PIX	HCAL	EN Dept	<b>RP</b>

PX56 Plug  
CLOSED

TX54 Plug  
CLOSED

2020

July - Week 30

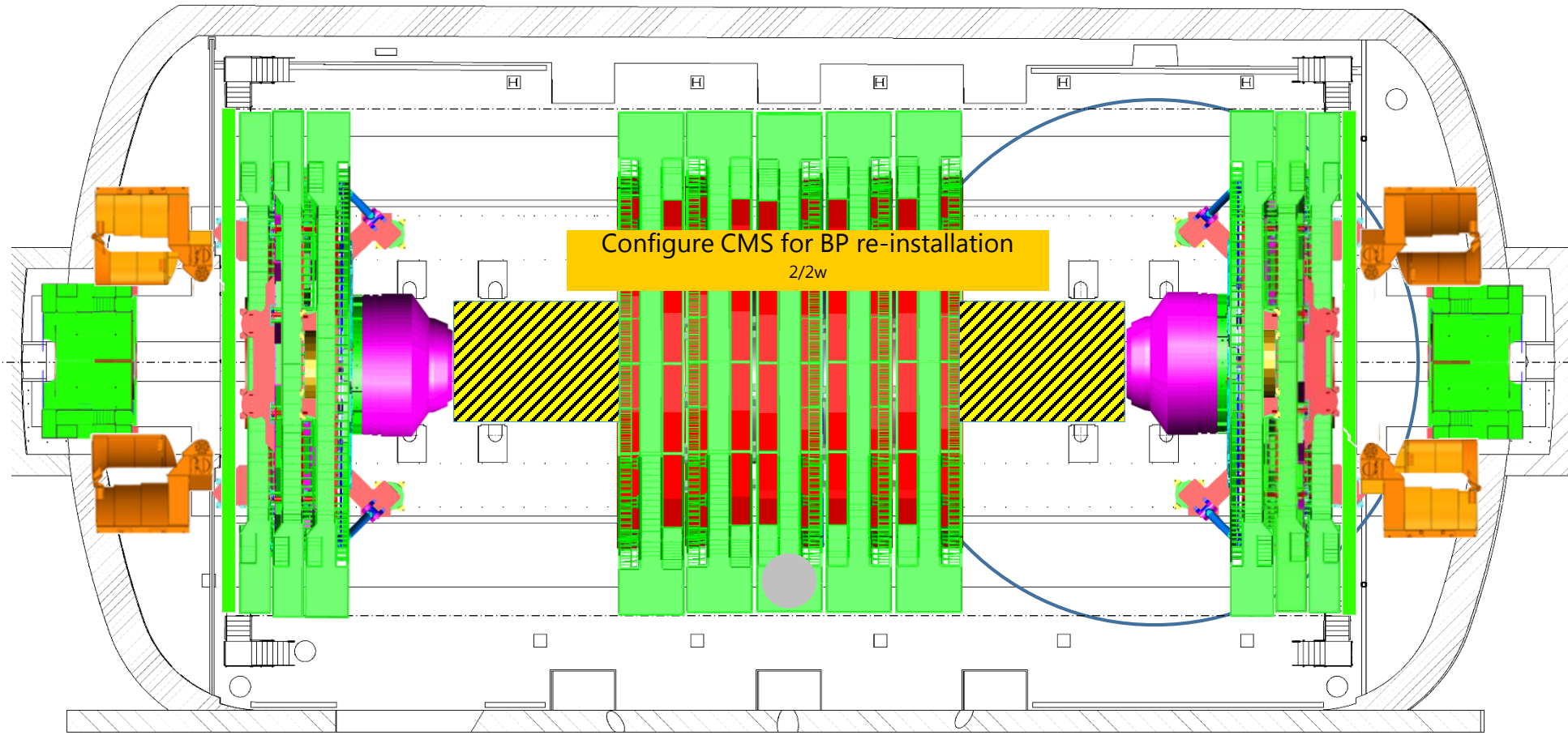
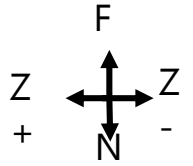

Configure CMS for BP re-installation  
2/2w

5m





Crane

Cryo.	■	EL power	■	Water cool.	■	Database	■
IT	■	Magnet	■	C6F14	■	Gas	■
SL. 0	GEM	ECAL	ZEC	DT+ RB	Survey	TE-VSC	GS Dept
CP. 0	TOTEM	CMX	CSC RE	TK PIX	HCAL	EN Dept	<b>RP</b>

PX56 Plug  
CLOSED

TX54 Plug  
CLOSED

2020

July - Week 31

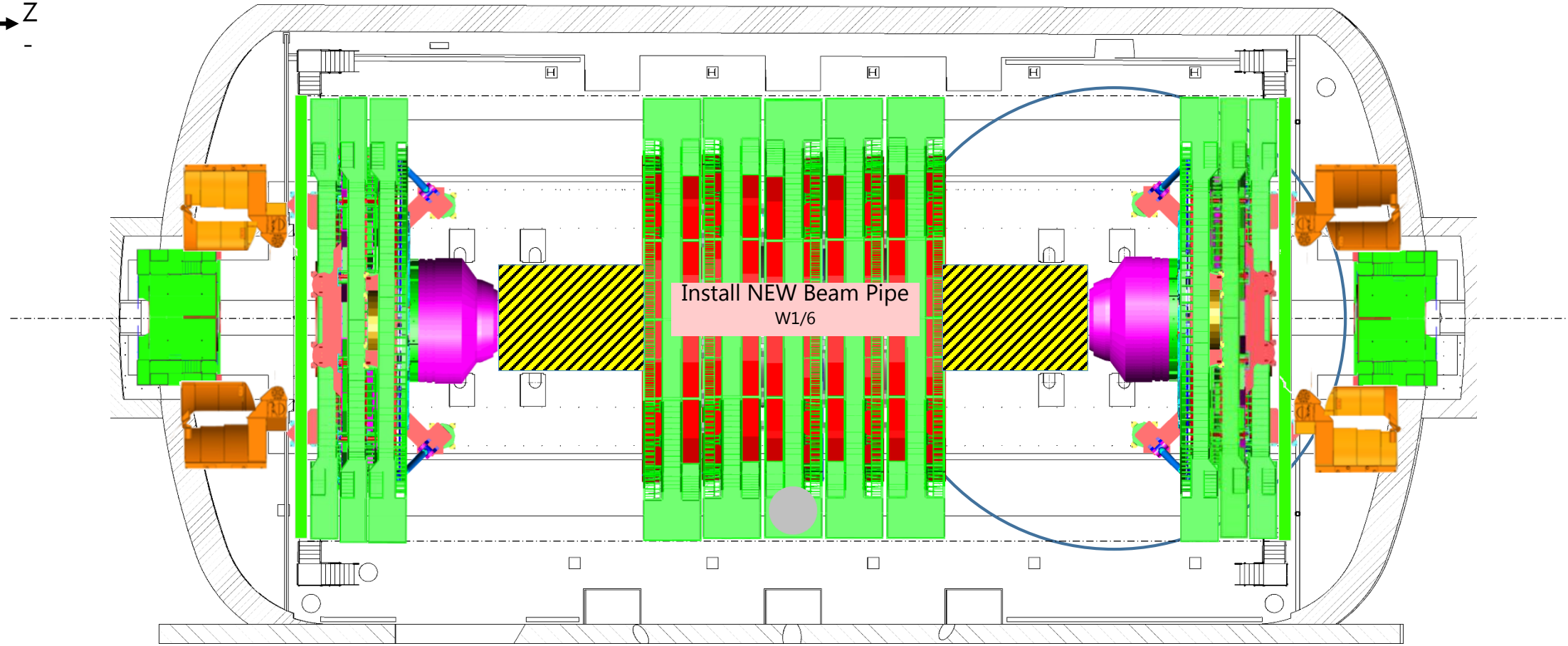
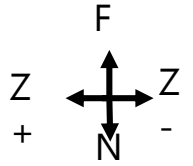

5m



Crane

Cryo.	█	EL power	█	Water cool.	█	Database	█
IT	█	Magnet	█	C6F14	█	Gas	█
SL. 0	GEM	ECAL	ZEC	DT+ RB	Survey	TE-VSC	GS Dept
CP. 0	TOTEM	CMX	CSC RE	TK PIX	HCAL	EN Dept	<b>RP</b>

PX56 Plug  
CLOSED

TX54 Plug  
CLOSED

2020

August - Week 32

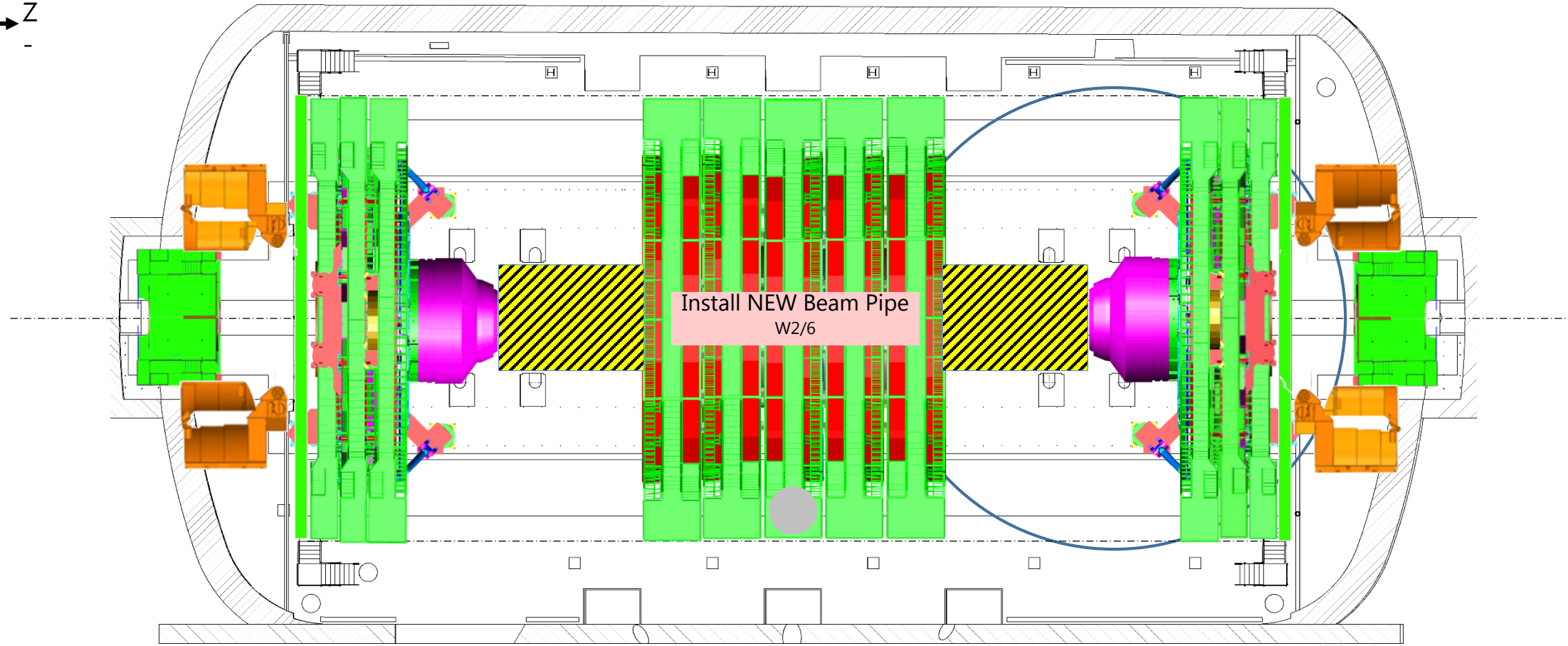
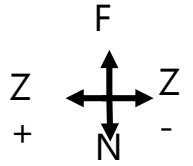

5m



Crane

Cryo.	<span style="background-color: green; color: green;">█</span>	EL power	<span style="background-color: green; color: green;">█</span>	Water cool.	<span style="background-color: green; color: green;">█</span>	Database	<span style="background-color: green; color: green;">█</span>
IT	<span style="background-color: green; color: green;">█</span>	Magnet	<span style="background-color: red; color: red;">█</span>	C6F14	<span style="background-color: green; color: green;">█</span>	Gas	<span style="background-color: green; color: green;">█</span>
SL. 0	<span style="background-color: teal; color: white;">GEM</span>	<span style="background-color: blue; color: white;">ECAL</span>	<span style="background-color: green; color: white;">ZEC</span>	<span style="background-color: yellow; color: black;">DT+ RB</span>	<span style="background-color: gray; color: white;">Survey</span>	<span style="background-color: pink; color: black;">TE-VSC</span>	<span style="background-color: brown; color: white;">GS Dept</span>
CP. 0	<span style="background-color: olive; color: white;">TOTEM</span>	<span style="background-color: yellow; color: black;">CMX</span>	<span style="background-color: cyan; color: black;">CSC RE</span>	<span style="background-color: purple; color: white;">TK PIX</span>	<span style="background-color: magenta; color: black;">HCAL</span>	<span style="background-color: orange; color: black;">EN Dept</span>	<span style="border: 2px solid black; padding: 2px;"><b>RP</b></span>

PX56 Plug  
CLOSED

TX54 Plug  
CLOSED

2020

August - Week 33

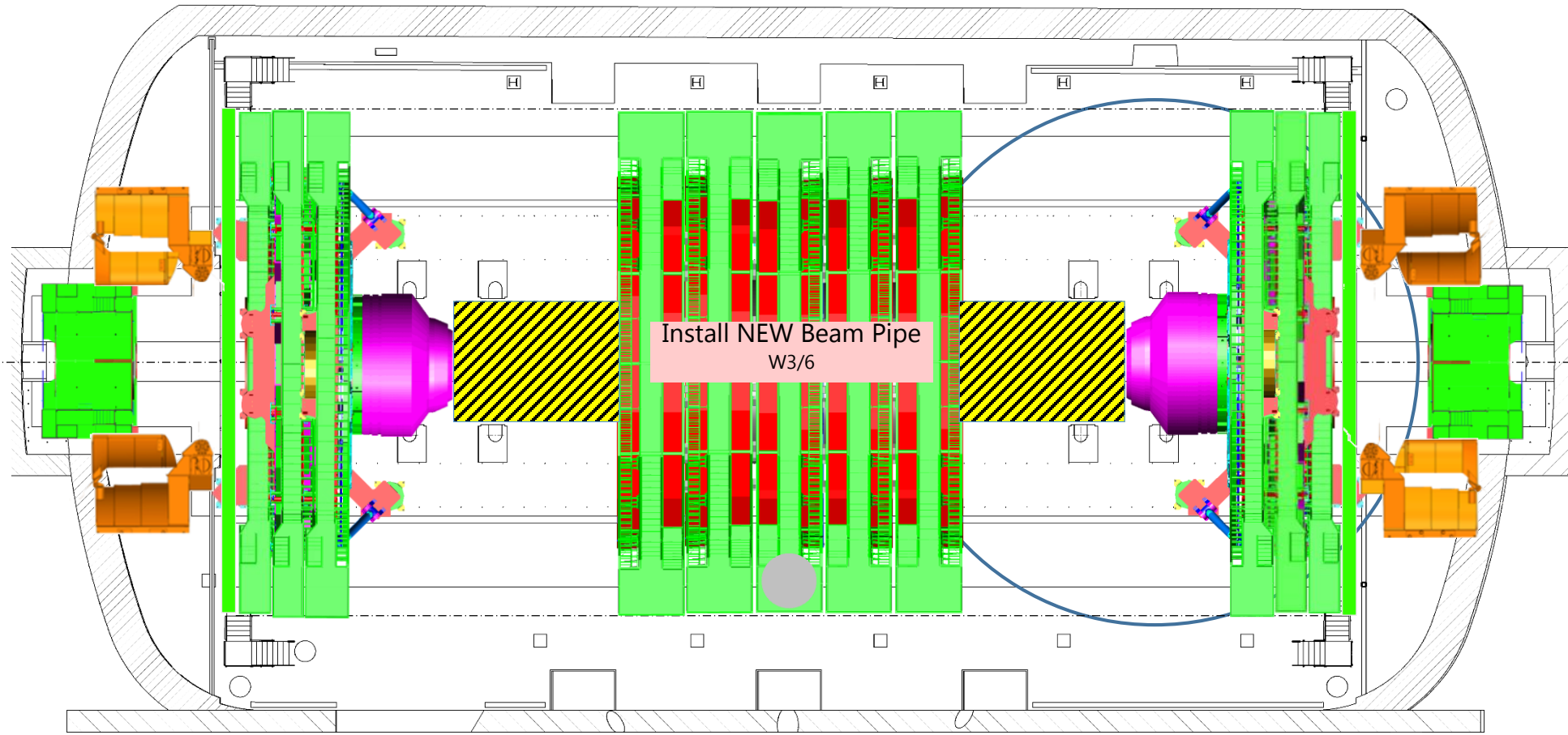
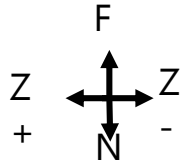

5m



Crane

Cryo.	<span style="background-color: green; color: green;">█</span>	EL power	<span style="background-color: green; color: green;">█</span>	Water cool.	<span style="background-color: green; color: green;">█</span>	Database	<span style="background-color: green; color: green;">█</span>
IT	<span style="background-color: green; color: green;">█</span>	Magnet	<span style="background-color: red; color: red;">█</span>	C6F14	<span style="background-color: green; color: green;">█</span>	Gas	<span style="background-color: green; color: green;">█</span>
SL. 0	<span style="background-color: teal; color: white;">GEM</span>	<span style="background-color: blue; color: white;">ECAL</span>	<span style="background-color: olive; color: white;">ZEC</span>	<span style="background-color: yellow; color: black;">DT+ RB</span>	<span style="background-color: gray; color: white;">Survey</span>	<span style="background-color: pink; color: black;">TE-VSC</span>	<span style="background-color: brown; color: white;">GS Dept</span>
CP. 0	<span style="background-color: olive; color: white;">TOTEM</span>	<span style="background-color: yellow; color: black;">CMX</span>	<span style="background-color: cyan; color: black;">CSC RE</span>	<span style="background-color: purple; color: white;">TK PIX</span>	<span style="background-color: magenta; color: black;">HCAL</span>	<span style="background-color: orange; color: black;">EN Dept</span>	<span style="border: 2px solid black; background-color: white; color: black; padding: 2px;">RP</span>

PX56 Plug  
CLOSED

TX54 Plug  
CLOSED

2020

August - Week 34

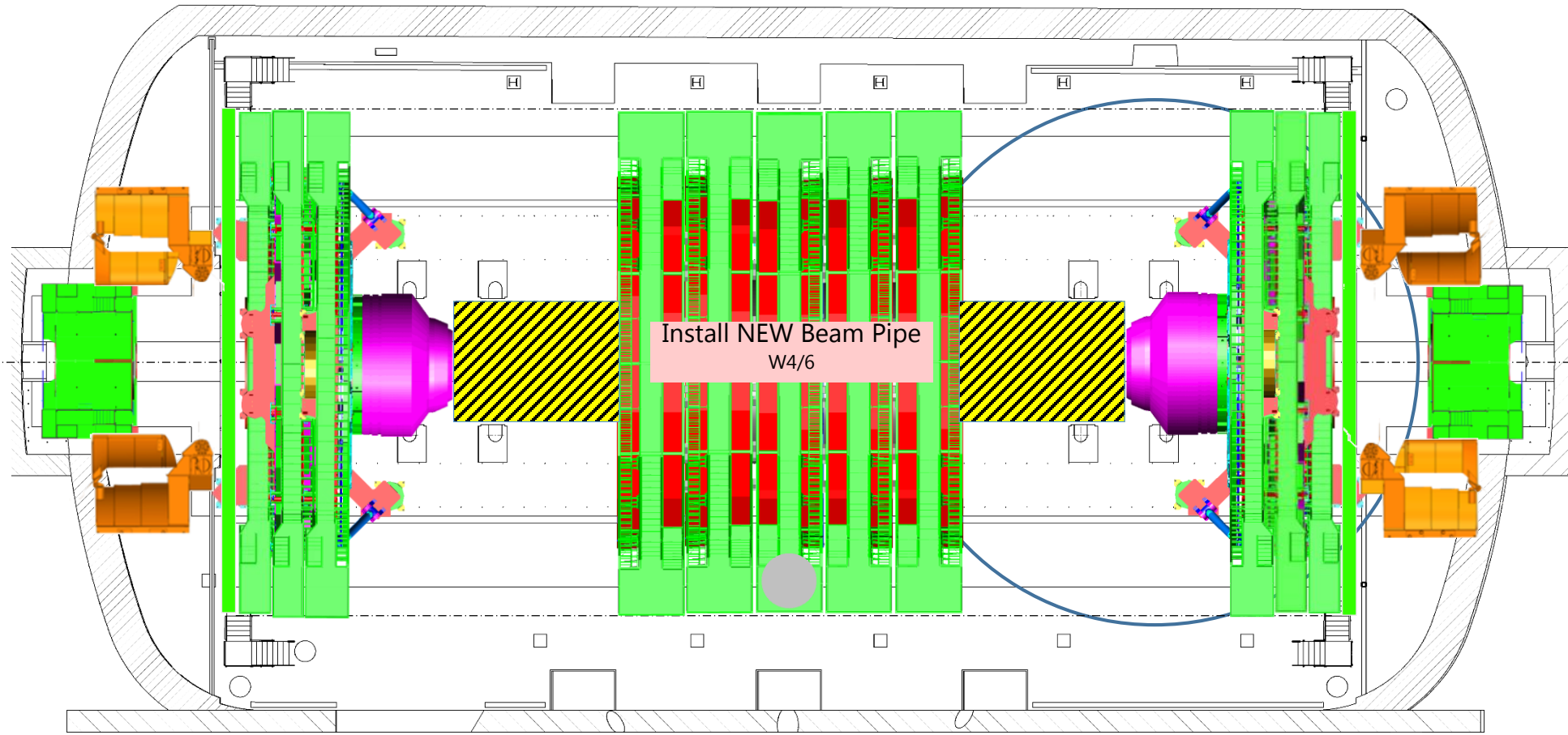
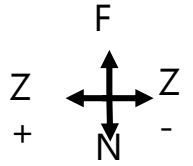

5m



Crane

Cryo.	■	EL power	■	Water cool.	■	Database	■
IT	■	Magnet	■	C6F14	■	Gas	■
SL. 0	GEM	ECAL	ZEC	DT+ RB	Survey	TE-VSC	GS Dept
CP. 0	TOTEM	CMX	CSC RE	TK PIX	HCAL	EN Dept	<b>RP</b>

PX56 Plug  
CLOSED

TX54 Plug  
CLOSED

2020

August - Week 35

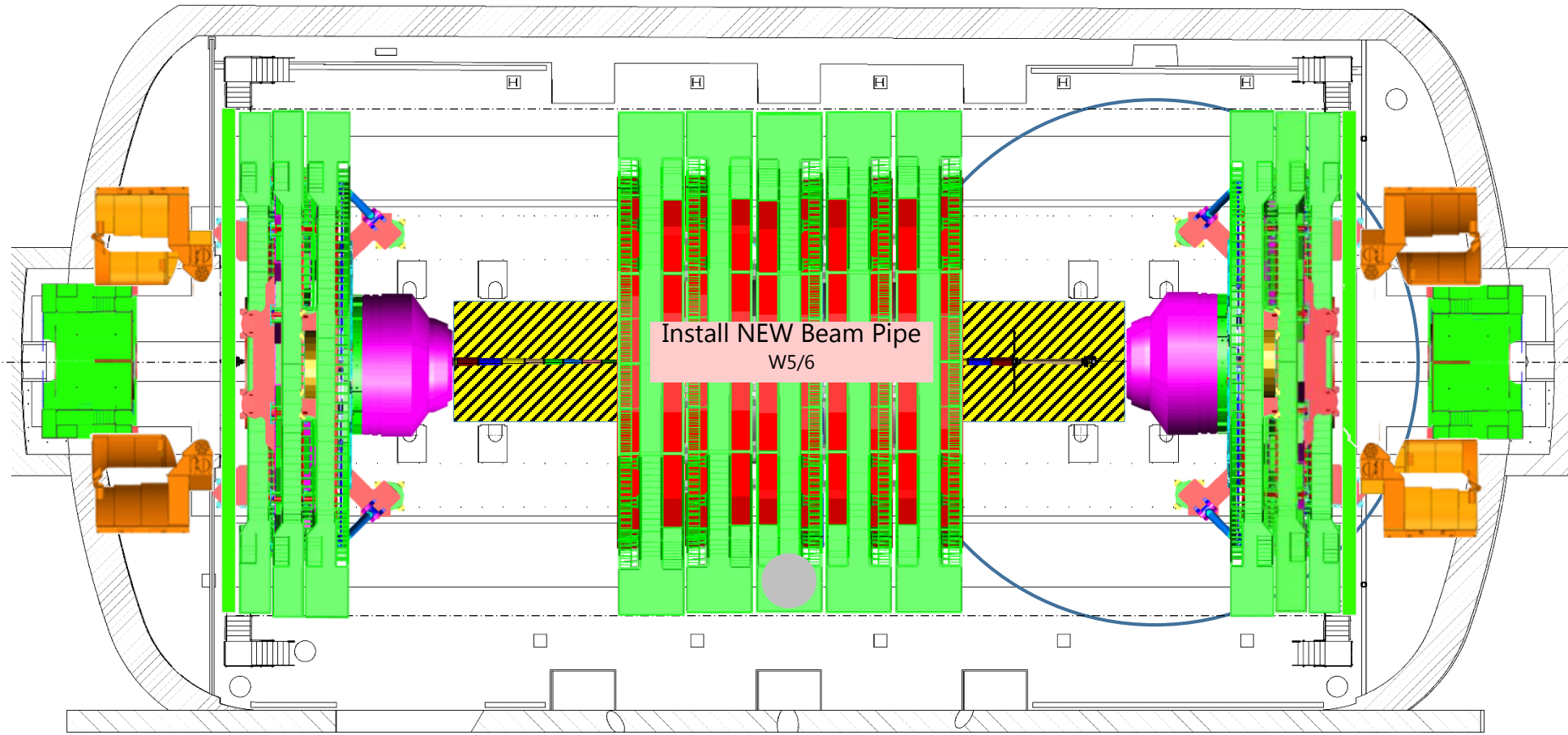
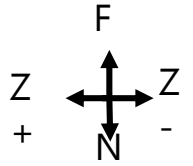

5m





Crane

Cryo.	■	EL power	■	Water cool.	■	Database	■
IT	■	Magnet	■	C6F14	■	Gas	■
SL. 0	GEM	ECAL	ZEC	DT+ RB	Survey	TE-VSC	GS Dept
CP. 0	TOTEM	CMX	CSC RE	TK PIX	HCAL	EN Dept	<b>RP</b>

PX56 Plug CLOSED
TX54 Plug CLOSED

2020
August - Week 36

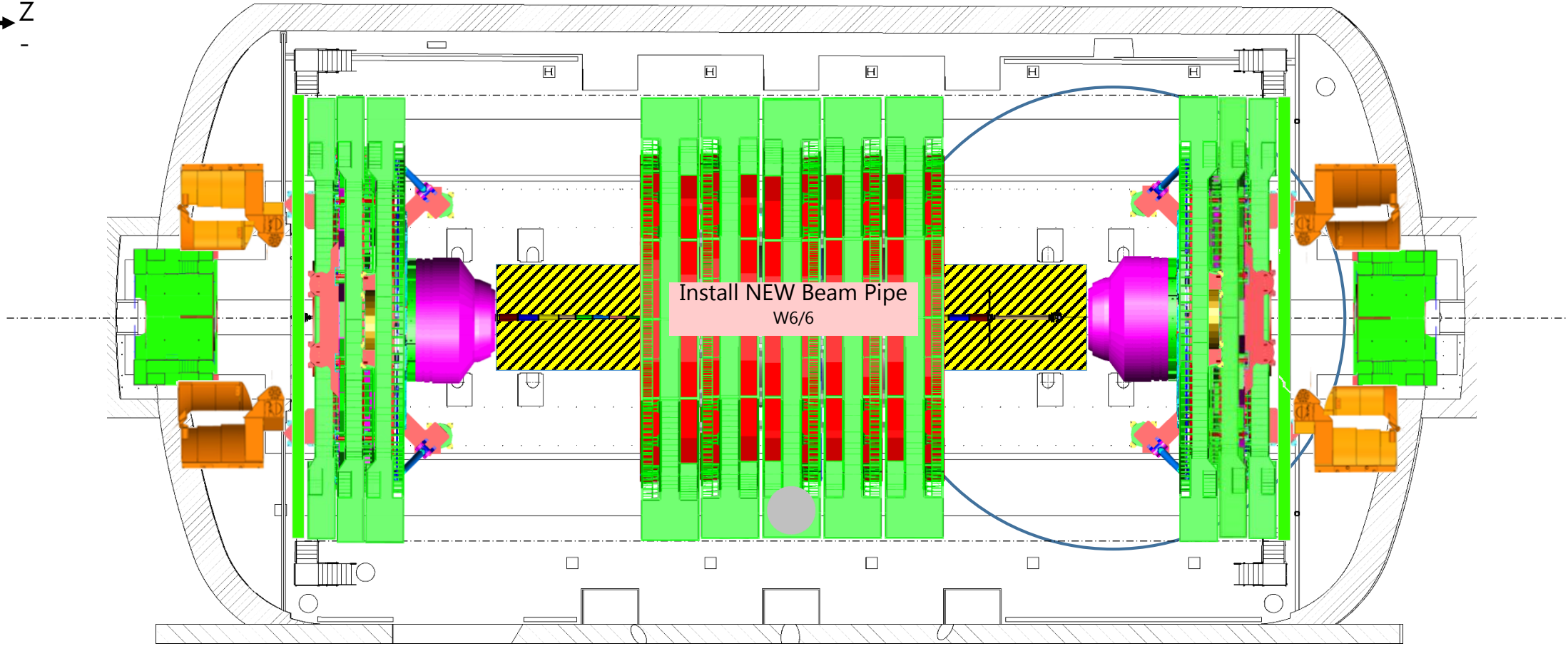
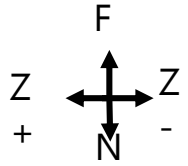

5m



Crane

Cryo.	█	EL power	█	Water cool.	█	Database	█
IT	█	Magnet	█	C6F14	█	Gas	█
SL. 0	GEM	ECAL	ZEC	DT+ RB	Survey	TE-VSC	GS Dept
CP. 0	TOTEM	CMX	CSC RE	TK PIX	HCAL	EN Dept	<b>RP</b>

PX56 Plug  
CLOSED

TX54 Plug  
CLOSED

2020

September - Week 37

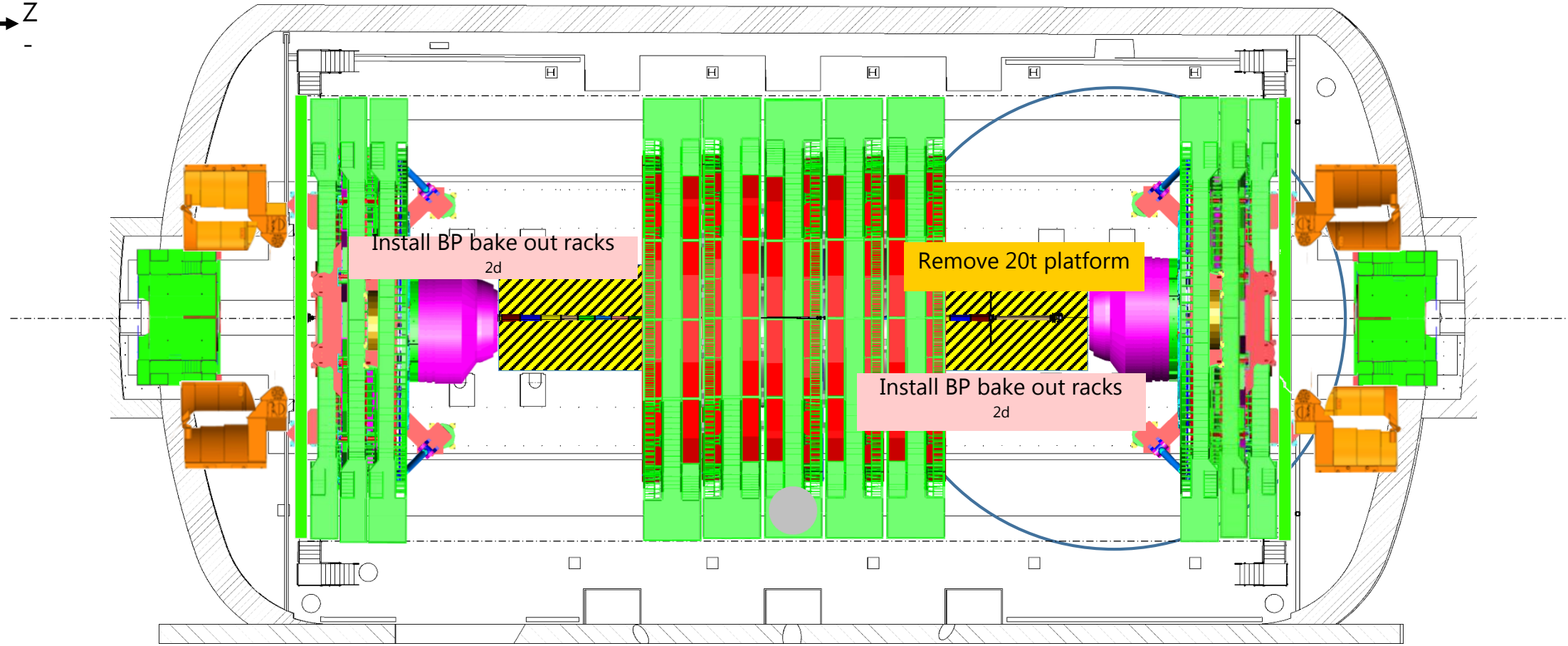
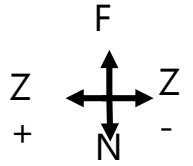

5m



Crane

Cryo.	■	EL power	■	Water cool.	■	Database	■
IT	■	Magnet	■	C6F14	■	Gas	■
SL. 0	GEM	ECAL	ZEC	DT+ RB	Survey	TE-VSC	GS Dept
CP. 0	TOTEM	CMX	CSC RE	TK PIX	HCAL	EN Dept	<b>RP</b>

PX56 Plug  
CLOSED

TX54 Plug  
CLOSED

2020

September - Week 38

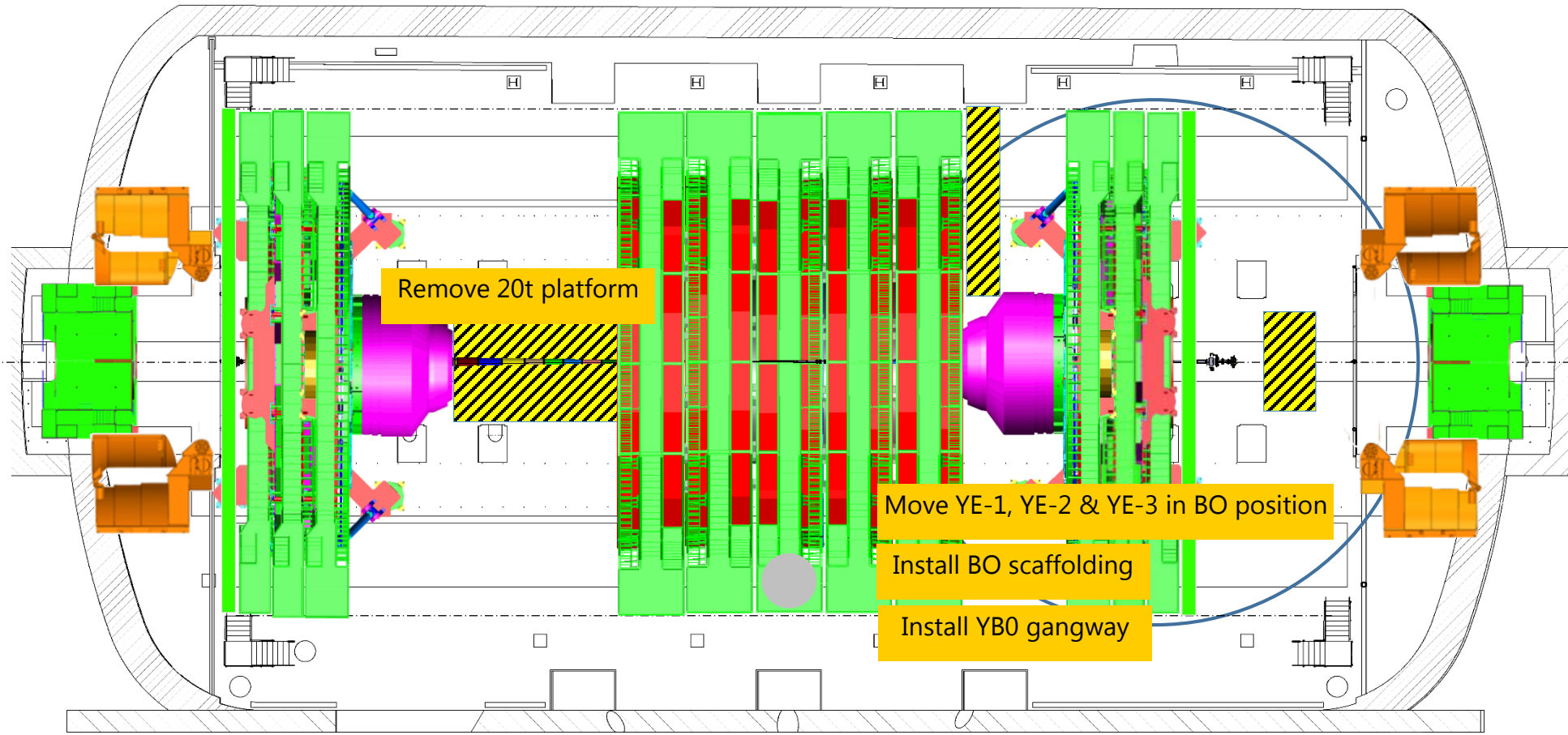
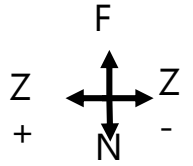

5m



Cryo.	<span style="color: green;">■</span>	EL power	<span style="color: green;">■</span>	Water cool.	<span style="color: green;">■</span>	Database	<span style="color: green;">■</span>
IT	<span style="color: green;">■</span>	Magnet	<span style="color: red;">■</span>	C6F14	<span style="color: green;">■</span>	Gas	<span style="color: green;">■</span>
SL. 0	<span style="background-color: #4682B4;">■</span> GEM	<span style="background-color: #4169E1;">■</span> ECAL	<span style="background-color: #808000;">■</span> ZEC	<span style="background-color: #FFD700;">■</span> DT+ RB	<span style="background-color: #696969;">■</span> Survey	<span style="background-color: #FFB6C1;">■</span> TE-VSC	<span style="background-color: #8B4513;">■</span> GS Dept
CP. 0	<span style="background-color: #6B8E23;">■</span> TOTEM	<span style="background-color: #FFD700;">■</span> CMX	<span style="background-color: #00FFFF;">■</span> CSC RE	<span style="background-color: #800080;">■</span> TK PIX	<span style="background-color: #FF00FF;">■</span> HCAL	<span style="background-color: #FF8C00;">■</span> EN Dept	<span style="border: 2px solid black; padding: 2px;">RP</span>

PX56 Plug CLOSED	2020
TX54 Plug CLOSED	September - Week 39

Crane

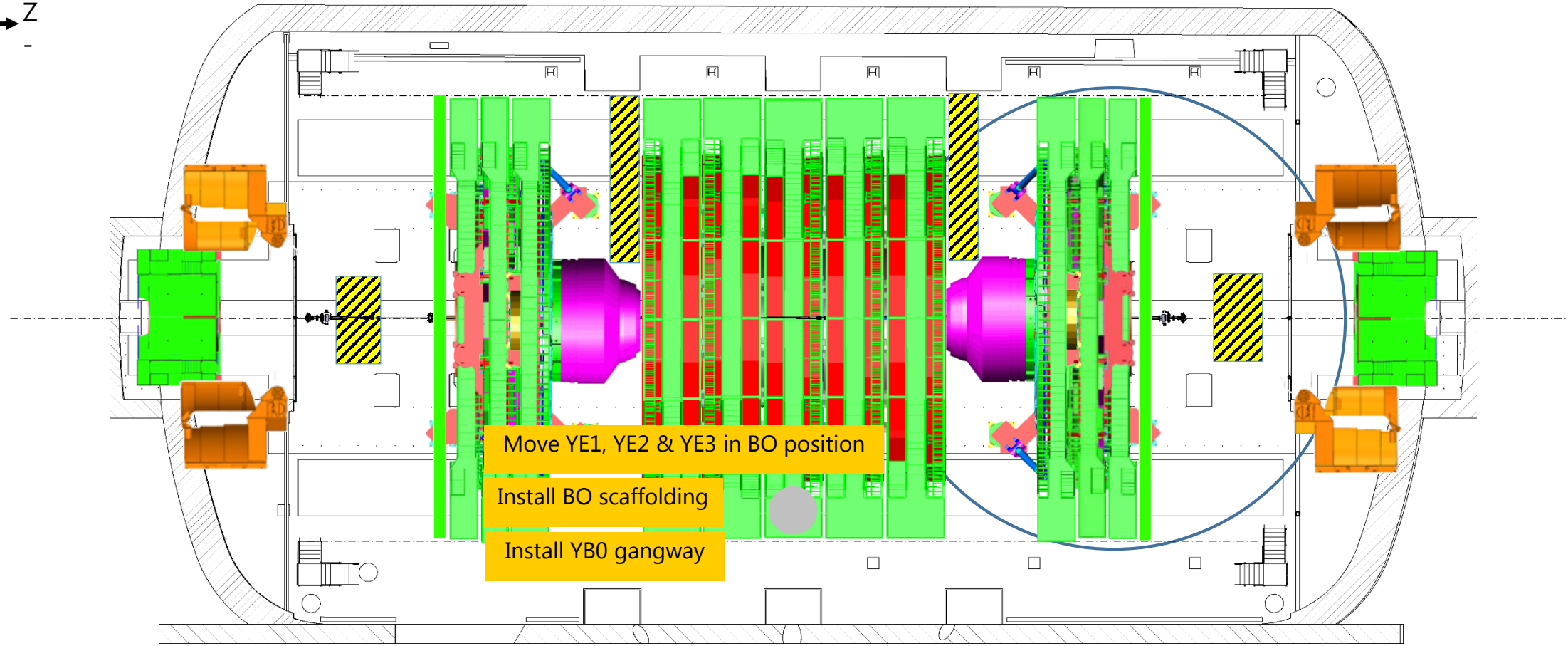
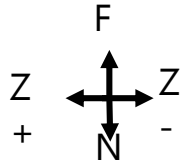

5m



Crane

Cryo.	<span style="background-color: green; width: 15px; height: 15px; display: inline-block;"></span>	EL power	<span style="background-color: green; width: 15px; height: 15px; display: inline-block;"></span>	Water cool.	<span style="background-color: green; width: 15px; height: 15px; display: inline-block;"></span>	Database	<span style="background-color: green; width: 15px; height: 15px; display: inline-block;"></span>
IT	<span style="background-color: green; width: 15px; height: 15px; display: inline-block;"></span>	Magnet	<span style="background-color: red; width: 15px; height: 15px; display: inline-block;"></span>	C6F14	<span style="background-color: green; width: 15px; height: 15px; display: inline-block;"></span>	Gas	<span style="background-color: green; width: 15px; height: 15px; display: inline-block;"></span>
SL. 0	<span style="background-color: teal; width: 15px; height: 15px; display: inline-block;"></span> GEM	<span style="background-color: blue; width: 15px; height: 15px; display: inline-block;"></span> ECAL	<span style="background-color: olive; width: 15px; height: 15px; display: inline-block;"></span> ZEC	<span style="background-color: yellow; width: 15px; height: 15px; display: inline-block;"></span> DT+ RB	<span style="background-color: gray; width: 15px; height: 15px; display: inline-block;"></span> Survey	<span style="background-color: pink; width: 15px; height: 15px; display: inline-block;"></span> TE-VSC	<span style="background-color: brown; width: 15px; height: 15px; display: inline-block;"></span> GS Dept
CP. 0	<span style="background-color: olive; width: 15px; height: 15px; display: inline-block;"></span> TOTEM	<span style="background-color: yellow; width: 15px; height: 15px; display: inline-block;"></span> CMX	<span style="background-color: cyan; width: 15px; height: 15px; display: inline-block;"></span> CSC RE	<span style="background-color: purple; width: 15px; height: 15px; display: inline-block;"></span> TK PIX	<span style="background-color: magenta; width: 15px; height: 15px; display: inline-block;"></span> HCAL	<span style="background-color: orange; width: 15px; height: 15px; display: inline-block;"></span> EN Dept	<span style="border: 2px solid black; padding: 2px;"><b>RP</b></span>

PX56 Plug  
CLOSED

TX54 Plug  
CLOSED

2020

September - Week 40

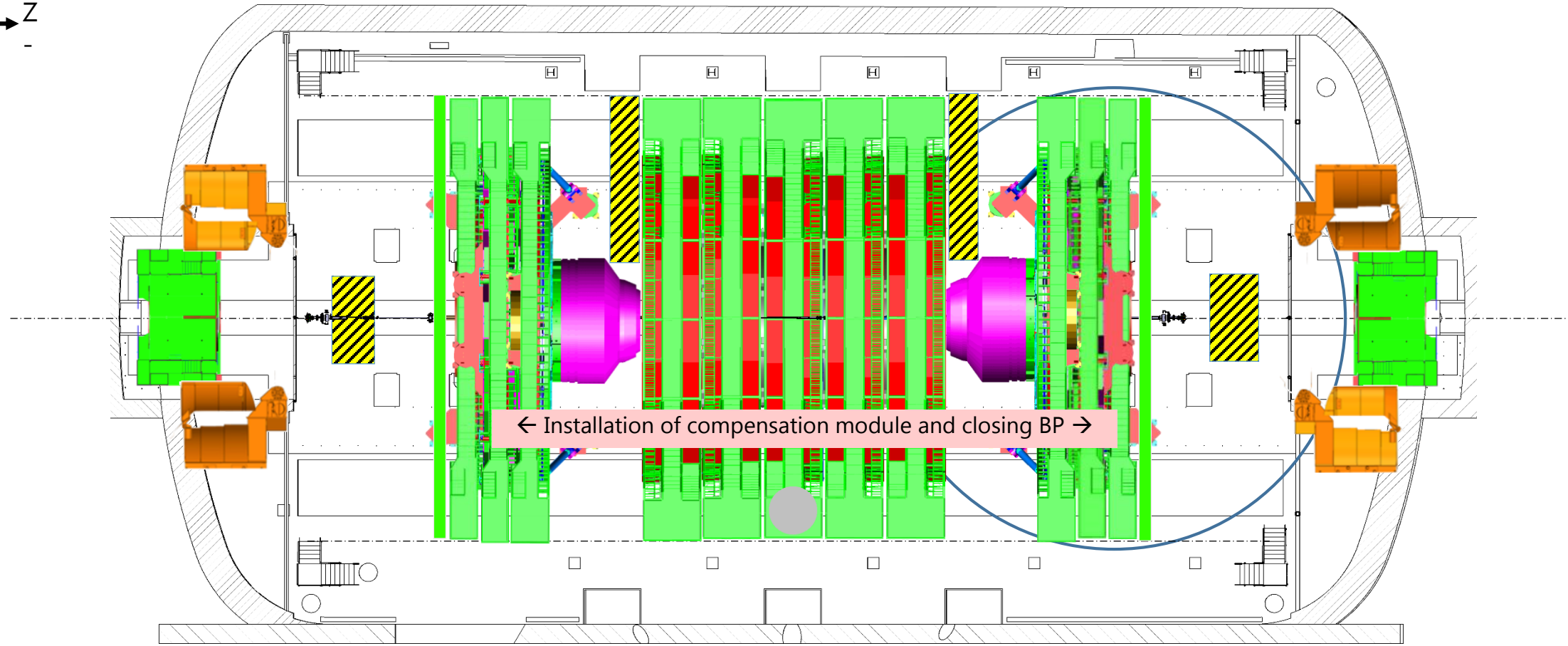
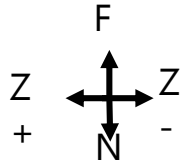

← Installation of compensation module and closing BP →

5m





Crane

Cryo.	■	EL power	■	Water cool.	■	Database	■
IT	■	Magnet	■	C6F14	■	Gas	■
SL. 0	GEM	ECAL	ZEC	DT+ RB	Survey	TE-VSC	GS Dept
CP. 0	TOTEM	CMX	CSC RE	TK PIX	HCAL	EN Dept	<b>RP</b>

PX56 Plug  
CLOSED

TX54 Plug  
CLOSED

2020

October - Week 41

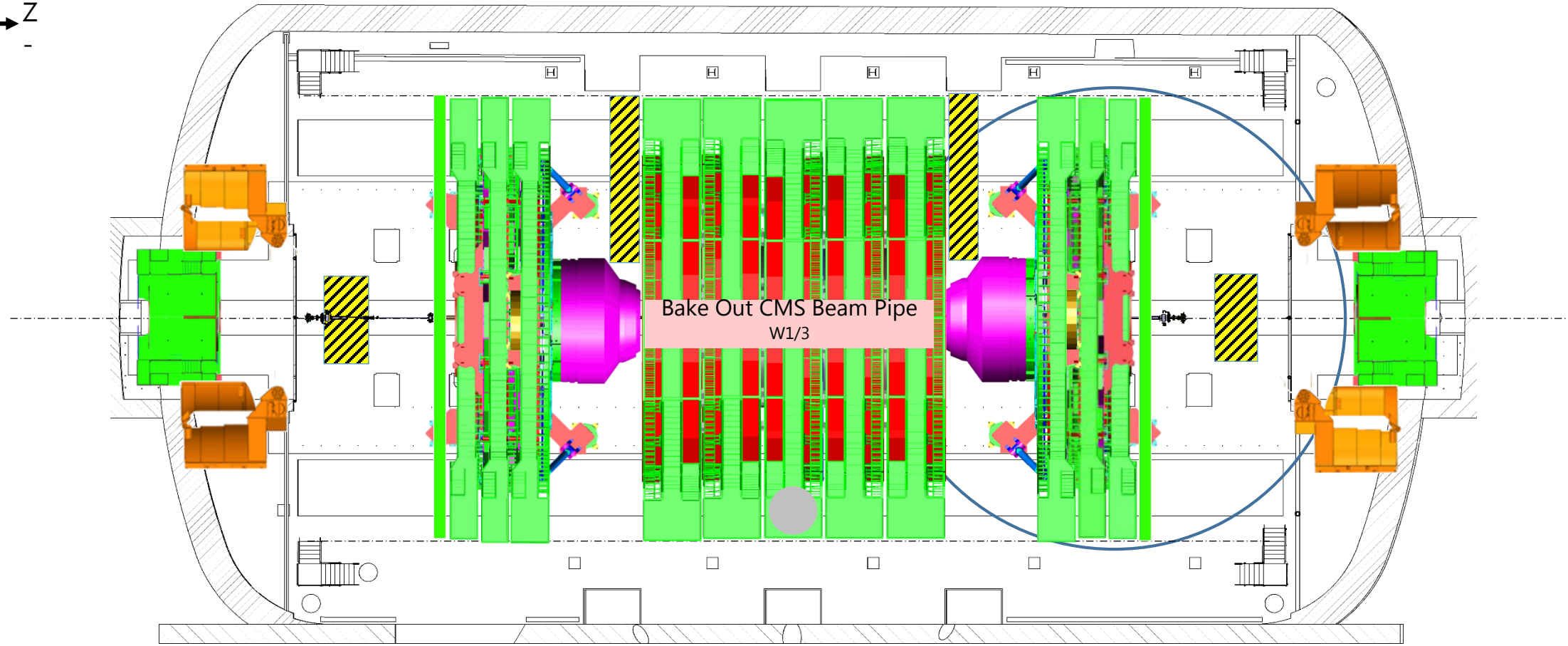
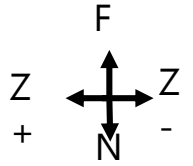

5m



Crane

Cryo.		EL power		Water cool.		Database	
IT		Magnet		C6F14		Gas	
SL. 0							
CP. 0							

PX56 Plug CLOSED
TX54 Plug CLOSED

2020
October - Week 42

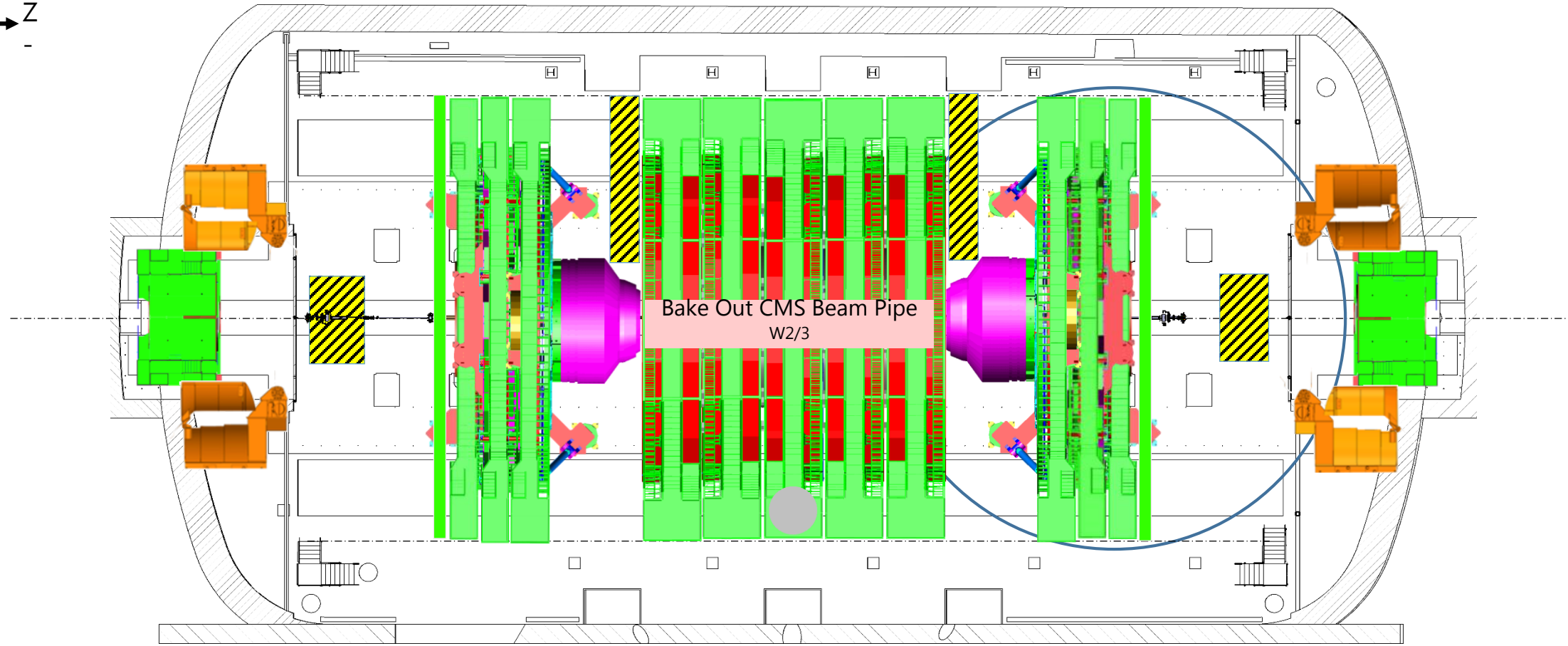
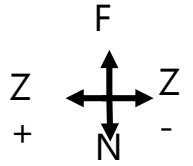

5m



Crane

Cryo.	<span style="background-color: green; color: green;">█</span>	EL power	<span style="background-color: green; color: green;">█</span>	Water cool.	<span style="background-color: green; color: green;">█</span>	Database	<span style="background-color: green; color: green;">█</span>
IT	<span style="background-color: green; color: green;">█</span>	Magnet	<span style="background-color: red; color: red;">█</span>	C6F14	<span style="background-color: green; color: green;">█</span>	Gas	<span style="background-color: green; color: green;">█</span>
SL. 0	<span style="background-color: teal; color: white;">GEM</span>	<span style="background-color: blue; color: white;">ECAL</span>	<span style="background-color: green; color: white;">ZEC</span>	<span style="background-color: yellow; color: black;">DT+ RB</span>	<span style="background-color: grey; color: white;">Survey</span>	<span style="background-color: pink; color: black;">TE-VSC</span>	<span style="background-color: brown; color: white;">GS Dept</span>
CP. 0	<span style="background-color: olive; color: white;">TOTEM</span>	<span style="background-color: yellow; color: black;">CMX</span>	<span style="background-color: cyan; color: black;">CSC RE</span>	<span style="background-color: purple; color: white;">TK PIX</span>	<span style="background-color: magenta; color: black;">HCAL</span>	<span style="background-color: orange; color: black;">EN Dept</span>	<span style="border: 2px solid black; background-color: white; color: black; padding: 2px;">RP</span>

PX56 Plug CLOSED
TX54 Plug CLOSED

2020
October - Week 43

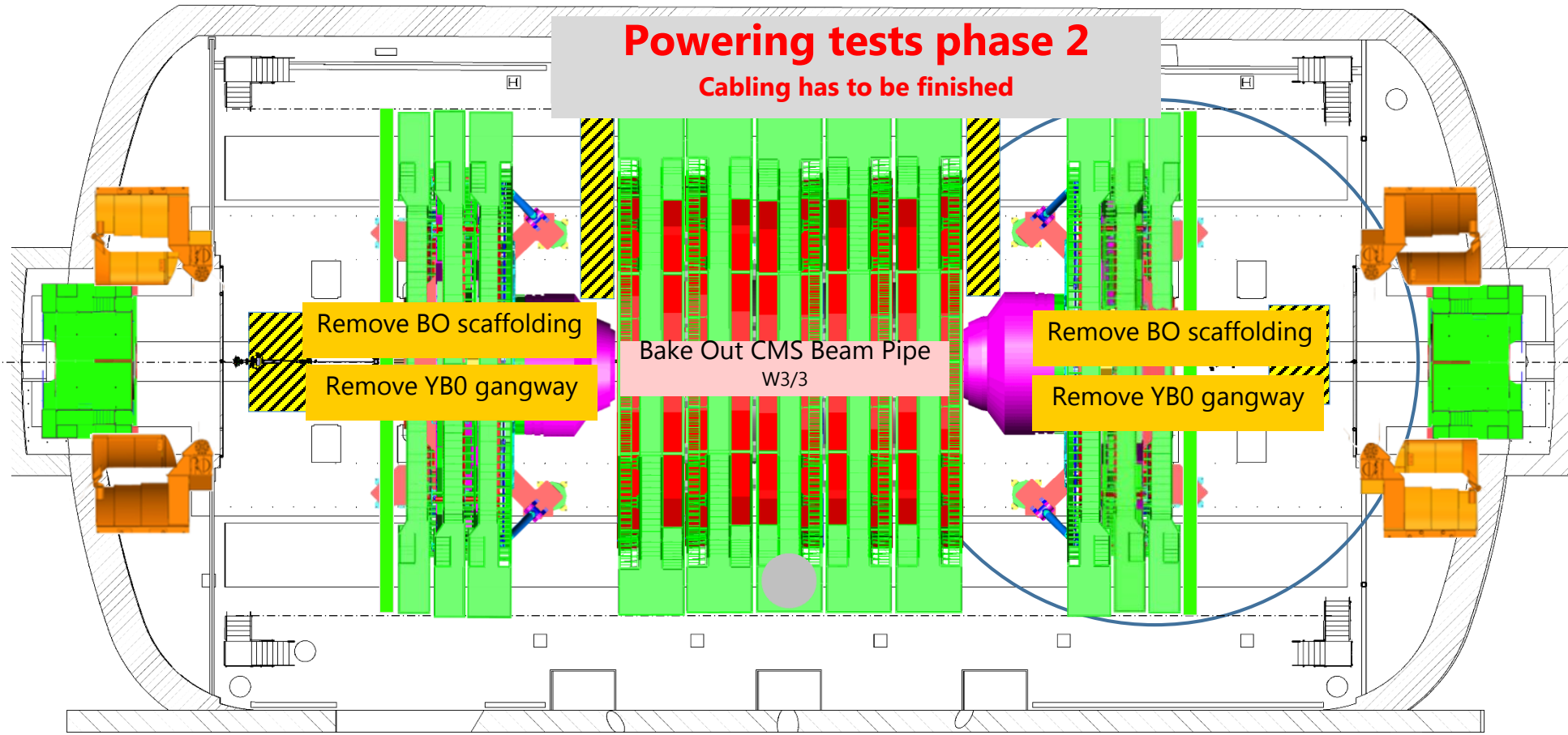
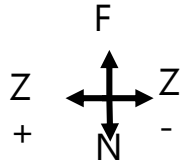

## Powering tests phase 2

Cabling has to be finished

Remove BO scaffolding

Remove YB0 gangway

Bake Out CMS Beam Pipe  
W3/3

Remove BO scaffolding

Remove YB0 gangway

5m



Cryo.	<span style="color: green;">■</span>	EL power	<span style="color: green;">■</span>	Water cool.	<span style="color: green;">■</span>	Database	<span style="color: green;">■</span>
IT	<span style="color: green;">■</span>	Magnet	<span style="color: red;">■</span>	C6F14	<span style="color: green;">■</span>	Gas	<span style="color: green;">■</span>
SL. 0	<span style="background-color: #008080; color: white;">GEM</span>	<span style="background-color: #4169E1; color: white;">ECAL</span>	<span style="background-color: #808000; color: white;">ZEC</span>	<span style="background-color: #FFD700; color: white;">DT+ RB</span>	<span style="background-color: #696969; color: white;">Survey</span>	<span style="background-color: #FFB6C1; color: white;">TE-VSC</span>	<span style="background-color: #8B4513; color: white;">GS Dept</span>
CP. 0	<span style="background-color: #6B8E23; color: white;">TOTEM</span>	<span style="background-color: #FFD700; color: white;">CMX</span>	<span style="background-color: #00FFFF; color: white;">CSC RE</span>	<span style="background-color: #800080; color: white;">TK PIX</span>	<span style="background-color: #FF00FF; color: white;">HCAL</span>	<span style="background-color: #FF8C00; color: white;">EN Dept</span>	<span style="border: 2px solid black; padding: 2px;"><span style="background-color: white; color: black;">RP</span></span>

PX56 Plug  
CLOSED

TX54 Plug  
CLOSED

2020

October - Week 44

Crane

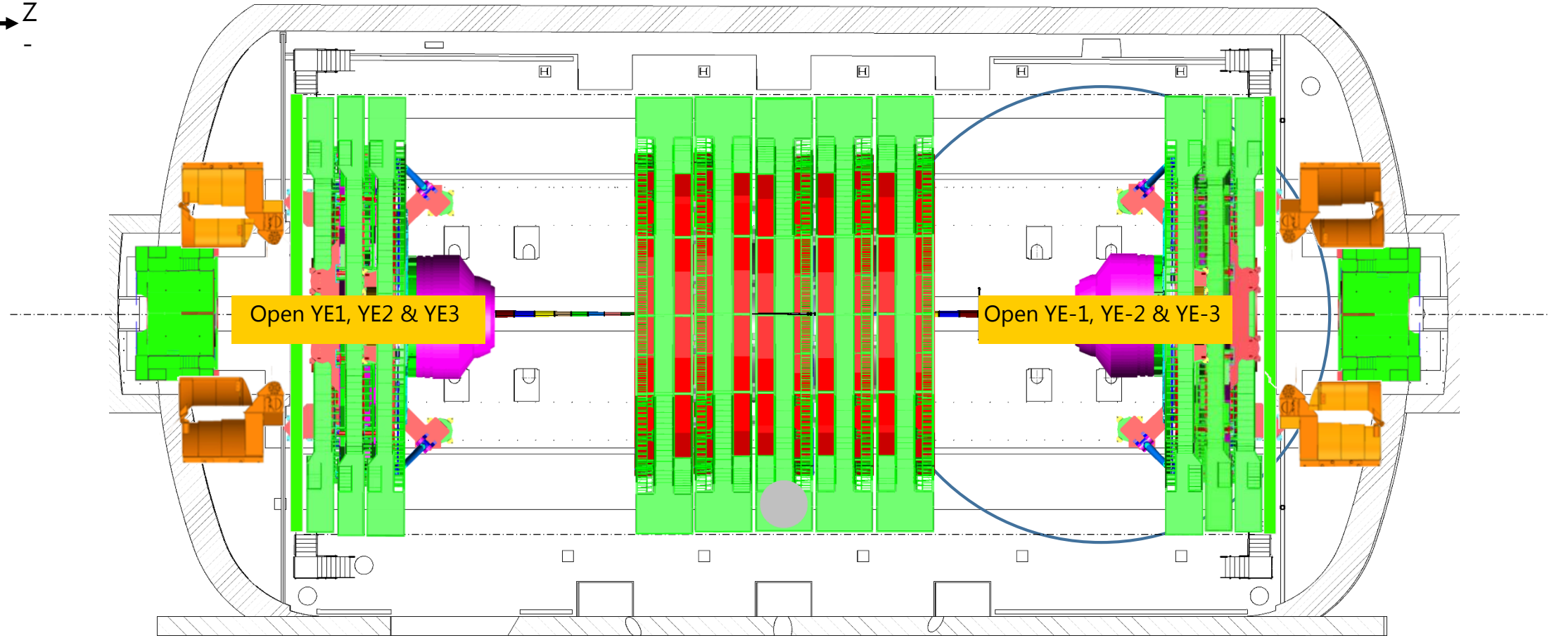
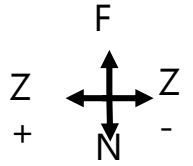

5m



Cryo.	█	EL power	█	Water cool.	█	Database	█
IT	█	Magnet	█	C6F14	█	Gas	█
SL. 0	GEM	ECAL	ZEC	DT+ RB	Survey	TE-VSC	GS Dept
CP. 0	TOTEM	CMX	CSC RE	TK PIX	HCAL	EN Dept	<b>RP</b>

PX56 Plug  
CLOSED

TX54 Plug  
CLOSED

2020

November - Week 45

Crane

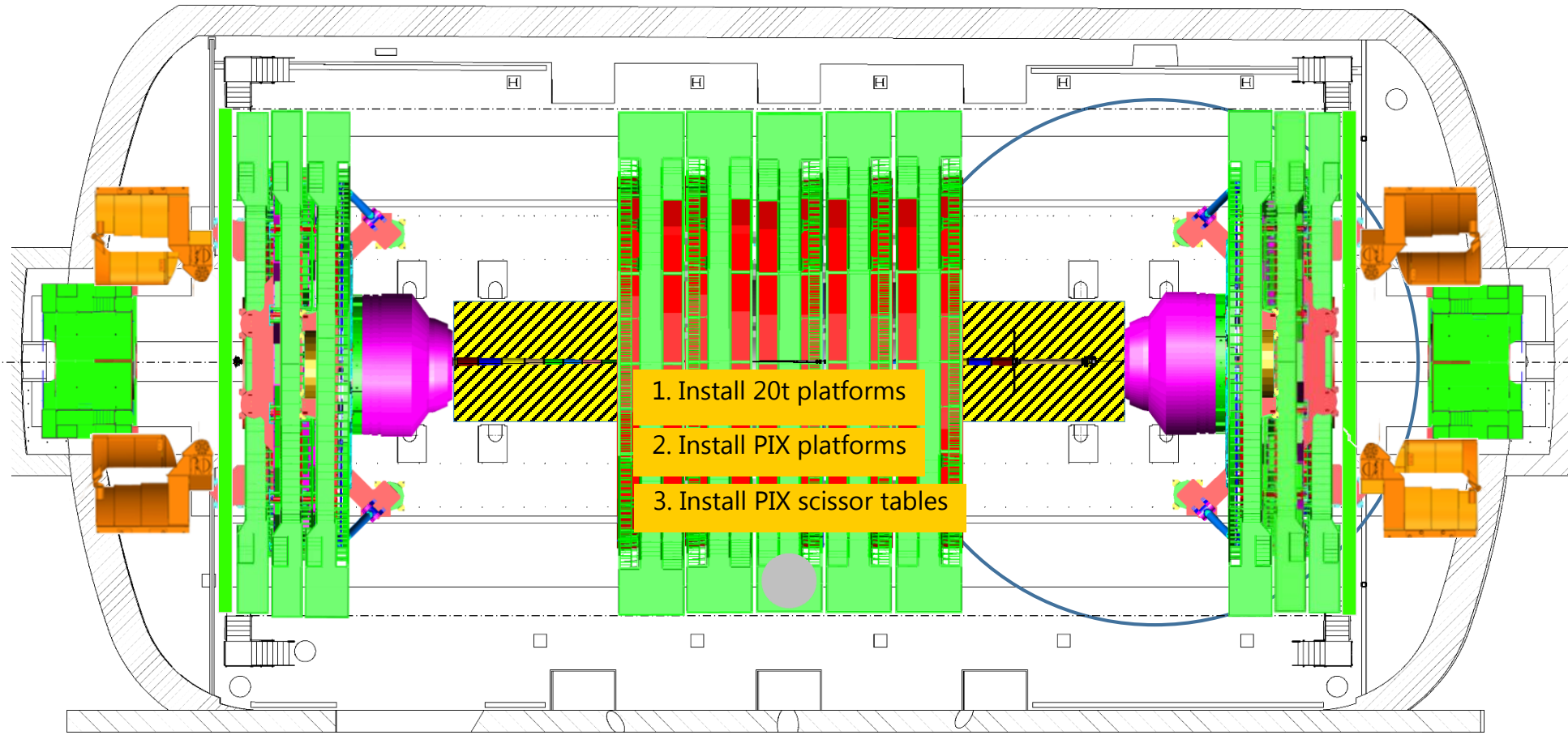
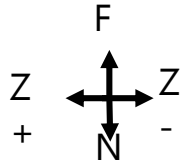

1. Install 20t platforms
2. Install PIX platforms
3. Install PIX scissor tables

5m





Crane

Cryo.	█	EL power	█	Water cool.	█	Database	█
IT	█	Magnet	█	C6F14	█	Gas	█
SL. 0	GEM	ECAL	ZEC	DT+ RB	Survey	TE-VSC	GS Dept
CP. 0	TOTEM	CMX	CSC RE	TK PIX	HCAL	EN Dept	<b>RP</b>

PX56 Plug  
CLOSED

TX54 Plug  
CLOSED

2020

November - Week 46

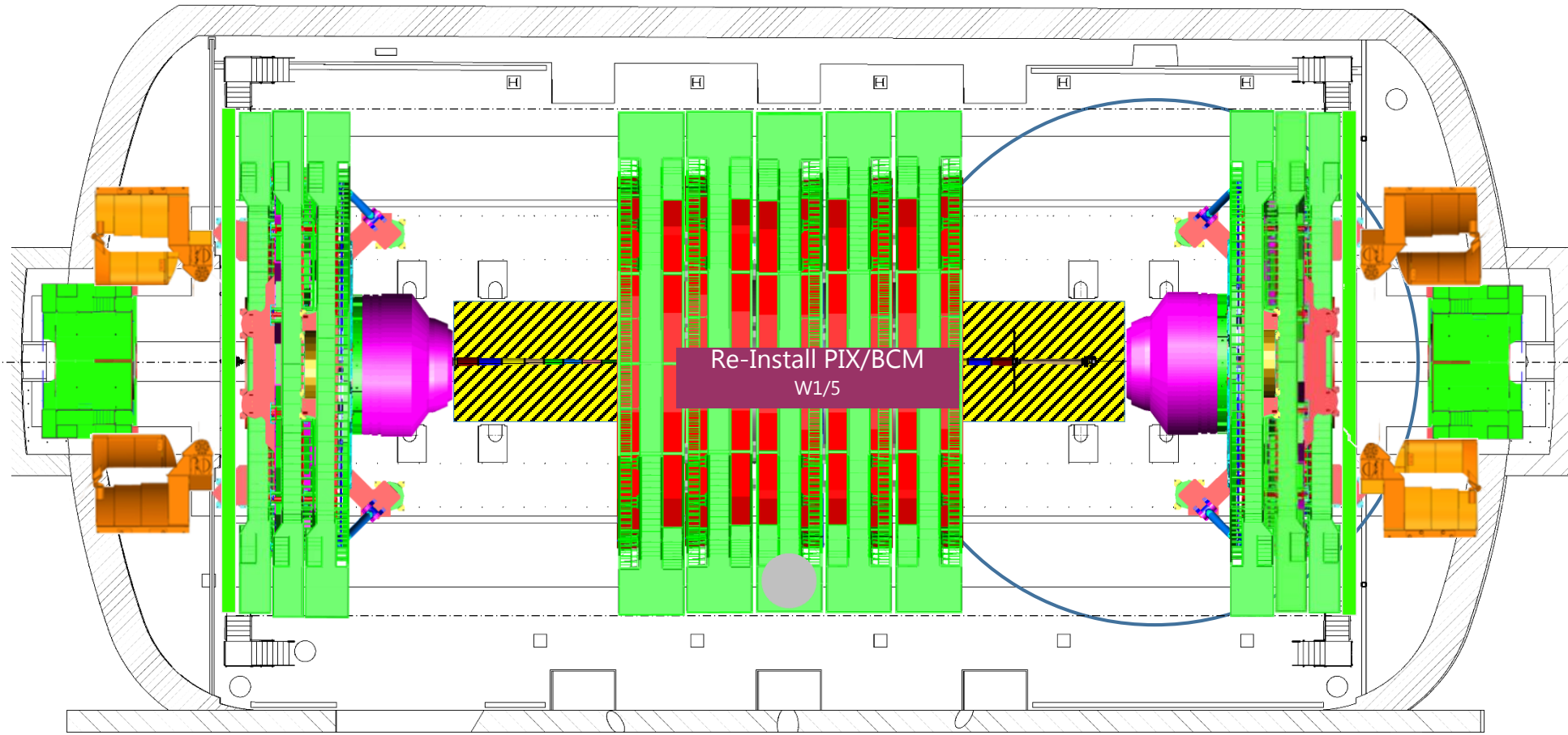

5m



Cryo.	█	EL power	█	Water cool.	█	Database	█
IT	█	Magnet	█	C6F14	█	Gas	█
SL. 0	GEM	ECAL	ZEC	DT+ RB	Survey	TE-VSC	GS Dept
CP. 0	TOTEM	CMX	CSC RE	TK PIX	HCAL	EN Dept	<b>RP</b>

PX56 Plug  
CLOSED

TX54 Plug  
CLOSED

2020

November - Week 47

Crane

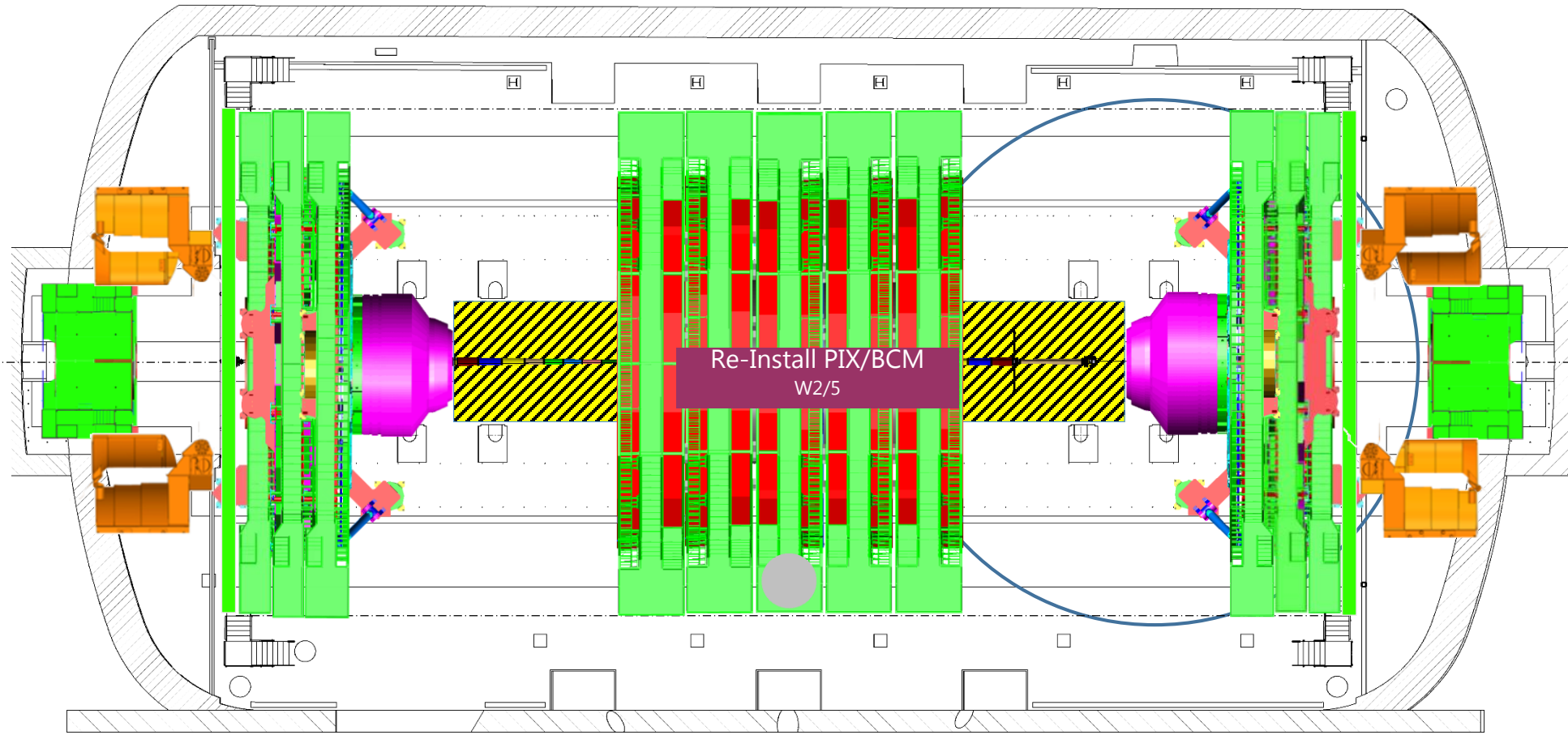
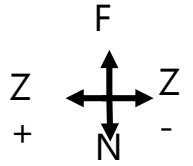

5m



Crane

Cryo.	█	EL power	█	Water cool.	█	Database	█
IT	█	Magnet	█	C6F14	█	Gas	█
SL. 0	GEM	ECAL	ZEC	DT+ RB	Survey	TE-VSC	GS Dept
CP. 0	TOTEM	CMX	CSC RE	TK PIX	HCAL	EN Dept	<b>RP</b>

PX56 Plug  
CLOSED

TX54 Plug  
CLOSED

2020

November - Week 48

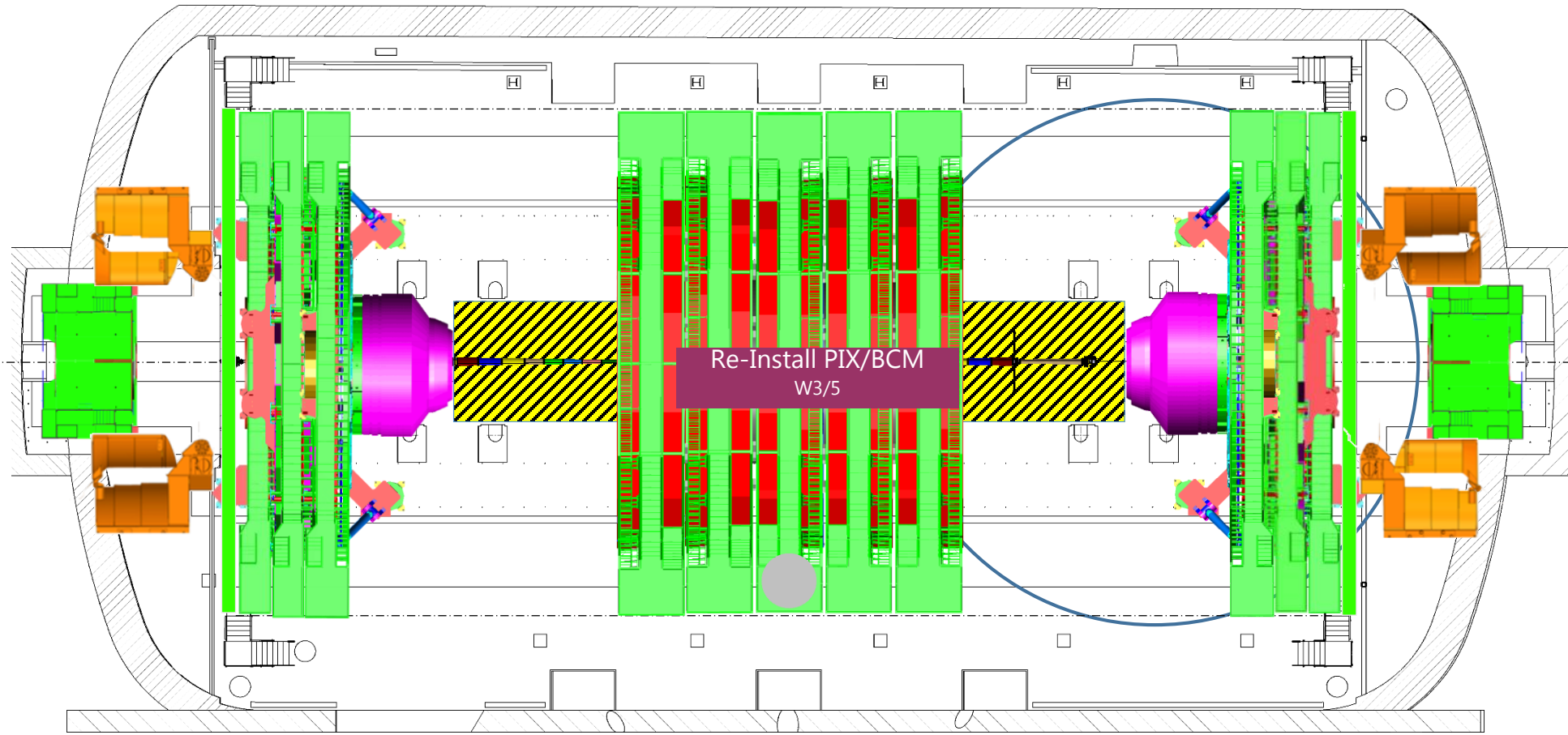
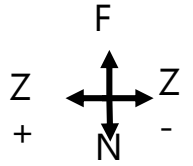

5m



Crane

Cryo.	█	EL power	█	Water cool.	█	Database	█
IT	█	Magnet	█	C6F14	█	Gas	█
SL. 0	GEM	ECAL	ZEC	DT+ RB	Survey	TE-VSC	GS Dept
CP. 0	TOTEM	CMX	CSC RE	TK PIX	HCAL	EN Dept	<b>RP</b>

PX56 Plug  
CLOSED

TX54 Plug  
CLOSED

2020

November - Week 49

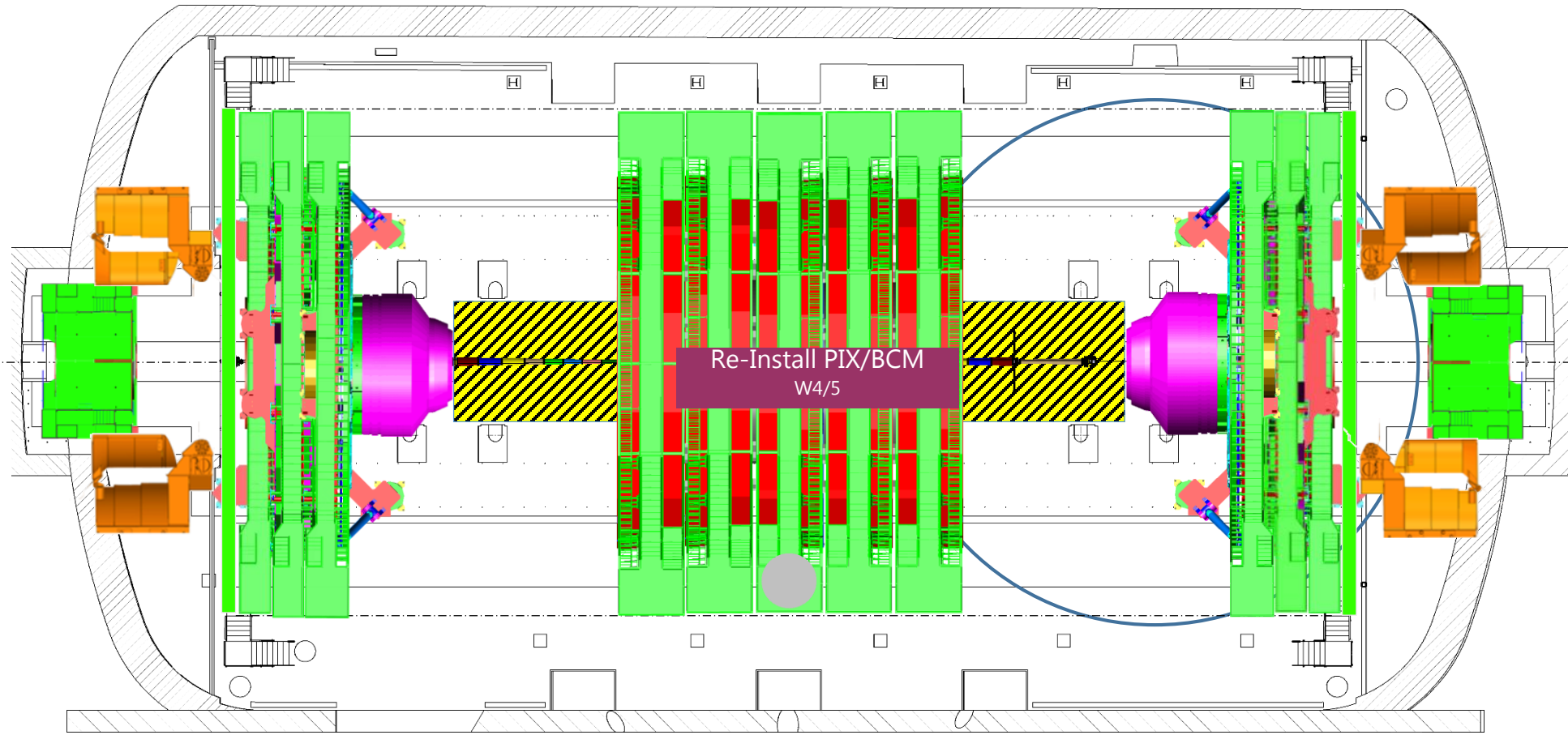
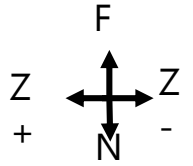



Crane

Cryo.	■	EL power	■	Water cool.	■	Database	■
IT	■	Magnet	■	C6F14	■	Gas	■
SL. 0	GEM	ECAL	ZEC	DT+ RB	Survey	TE-VSC	GS Dept
CP. 0	TOTEM	CMX	CSC RE	TK PIX	HCAL	EN Dept	<b>RP</b>

PX56 Plug  
CLOSED

TX54 Plug  
CLOSED

2020

December - Week 50

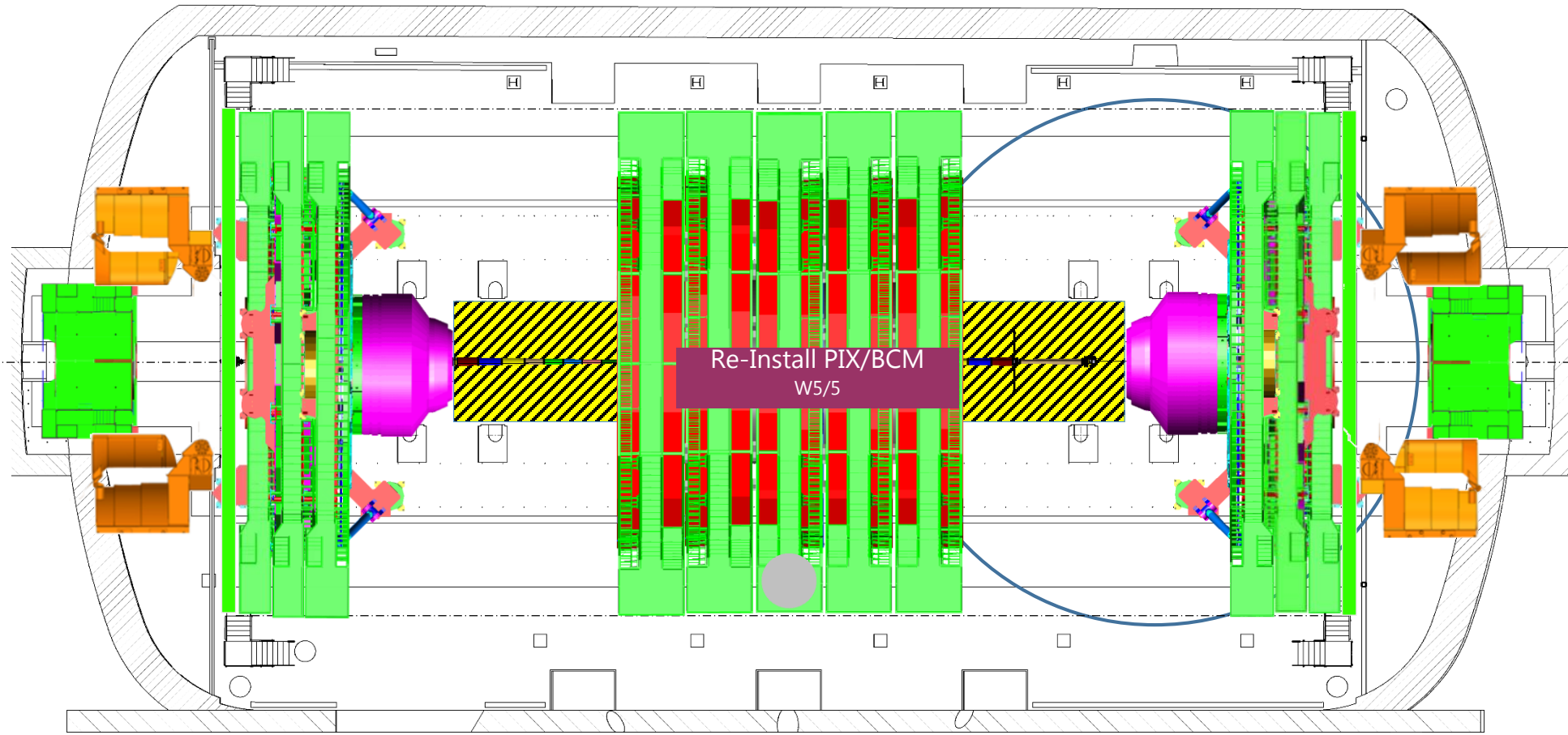
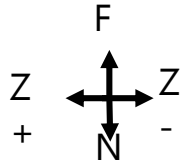

5m





Crane

Cryo.	■	EL power	■	Water cool.	■	Database	■
IT	■	Magnet	■	C6F14	■	Gas	■
SL. 0	GEM	ECAL	ZEC	DT+ RB	Survey	TE-VSC	GS Dept
CP. 0	TOTEM	CMX	CSC RE	TK PIX	HCAL	EN Dept	<b>RP</b>

PX56 Plug CLOSED
TX54 Plug CLOSED

2020
December - Week 51

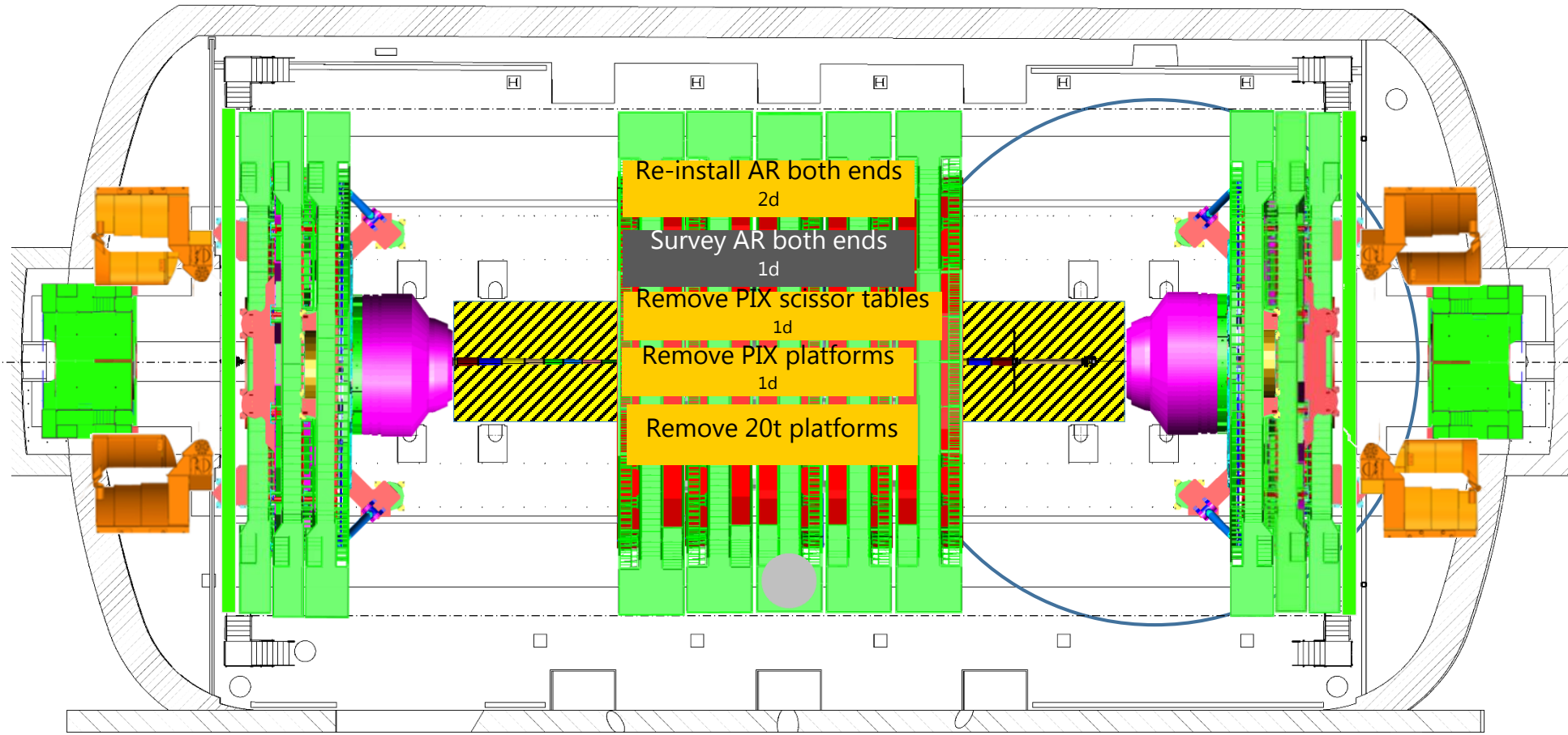
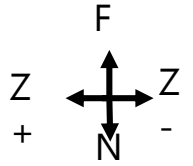

5m



Crane

Cryo.	■	EL power	■	Water cool.	■	Database	■								
IT	■	Magnet	■	C6F14	■	Gas	■								
SL.	0	GEM	■	ECAL	■	ZEC	■	DT+ RB	■	Survey	■	TE-VSC	■	GS Dept	■
CP.	0	TOTEM	■	CMX	■	CSC RE	■	TK PIX	■	HCAL	■	EN Dept	■	<b>RP</b>	■

PX56 Plug  
CLOSED

TX54 Plug  
CLOSED

2020

December - Week 52

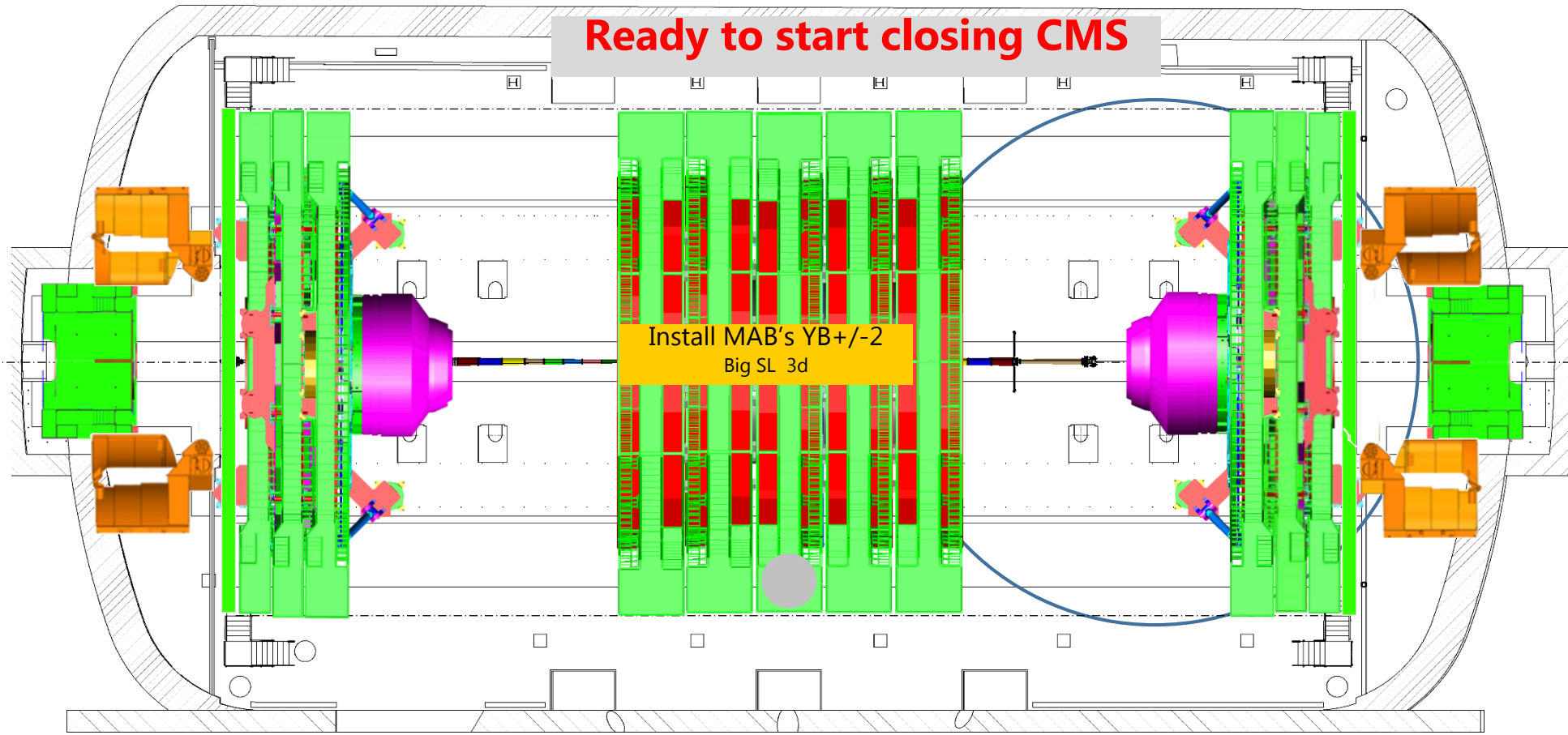
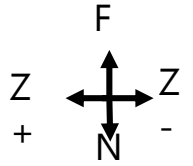

5m



Crane

Cryo.	█	EL power	█	Water cool.	█	Database	█
IT	█	Magnet	█	C6F14	█	Gas	█
SL. 0	GEM	ECAL	ZEC	DT+ RB	Survey	TE-VSC	GS Dept
CP. 0	TOTEM	CMX	CSC RE	TK PIX	HCAL	EN Dept	<b>RP</b>

PX56 Plug  
CLOSED

2020

TX54 Plug  
CLOSED

December - Week 53

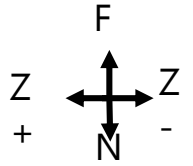

End of year lab closure

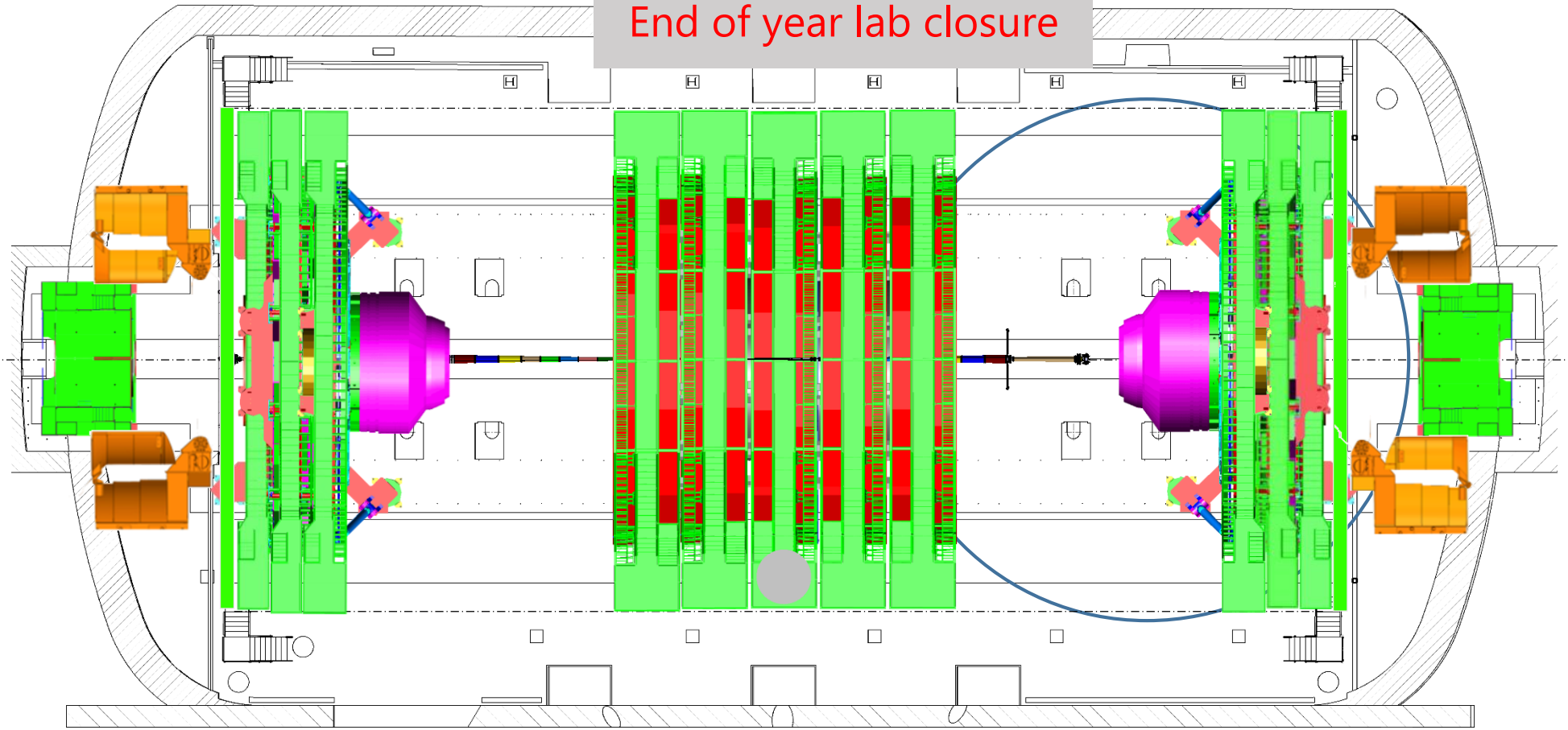

5m



Crane

Cryo.	█	EL power	█	Water cool.	█	Database	█
IT	█	Magnet	█	C6F14	█	Gas	█
SL. 0	GEM	ECAL	ZEC	DT+ RB	Survey	TE-VSC	GS Dept
CP. 0	TOTEM	CMX	CSC RE	TK PIX	HCAL	EN Dept	<b>RP</b>

PX56 Plug  
CLOSED

2021

TX54 Plug  
CLOSED

January - Week 1

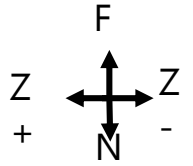

End of year lab closure

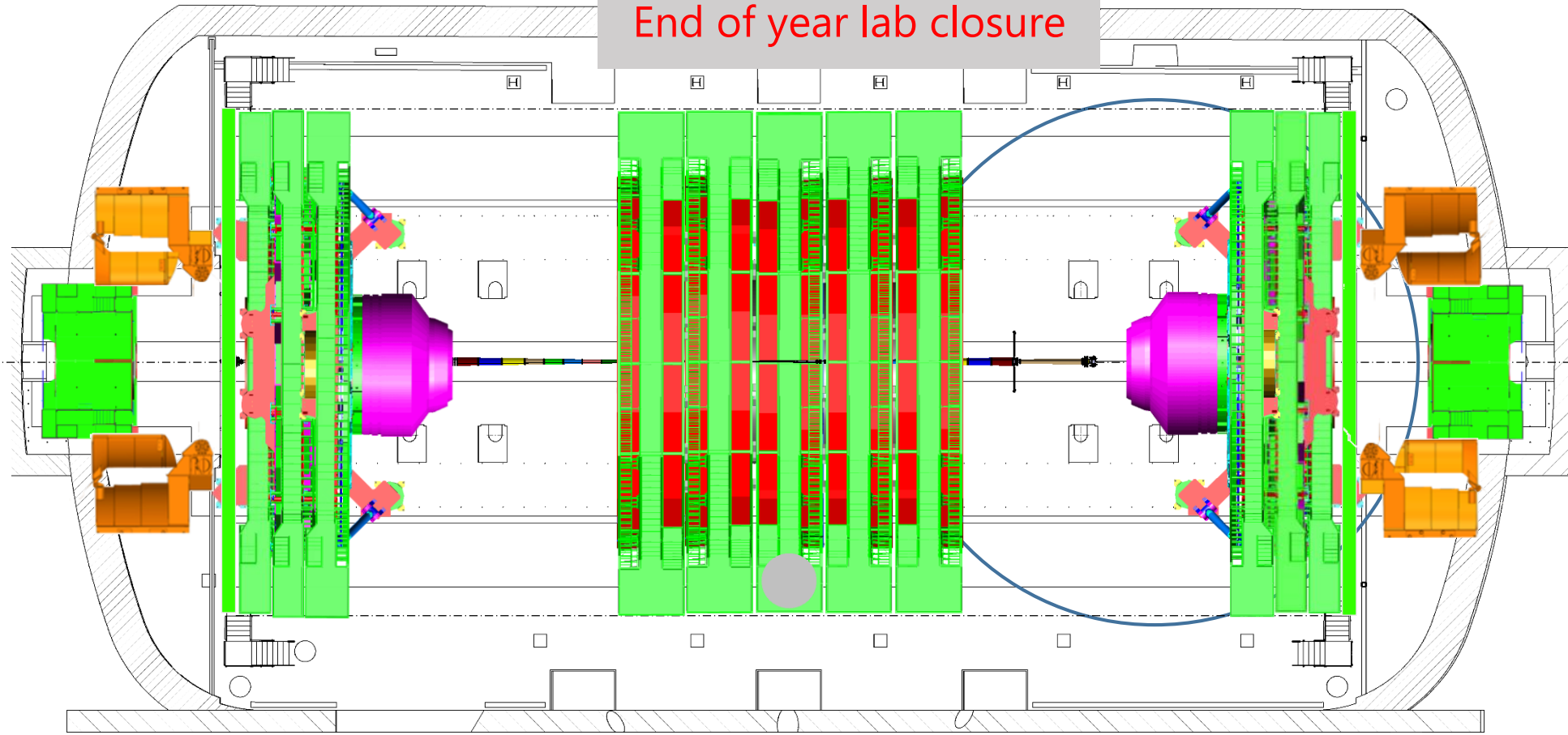

5m



Cryo.	■	EL power	■	Water cool.	■	Database	■
IT	■	Magnet	■	C6F14	■	Gas	■
SL. 0	GEM	ECAL	ZEC	DT+ RB	Survey	TE-VSC	GS Dept
CP. 0	TOTEM	CMX	CSC RE	TK PIX	HCAL	EN Dept	<b>RP</b>

PX56 Plug CLOSED	2021
TX54 Plug CLOSED	January - Week 2

Crane

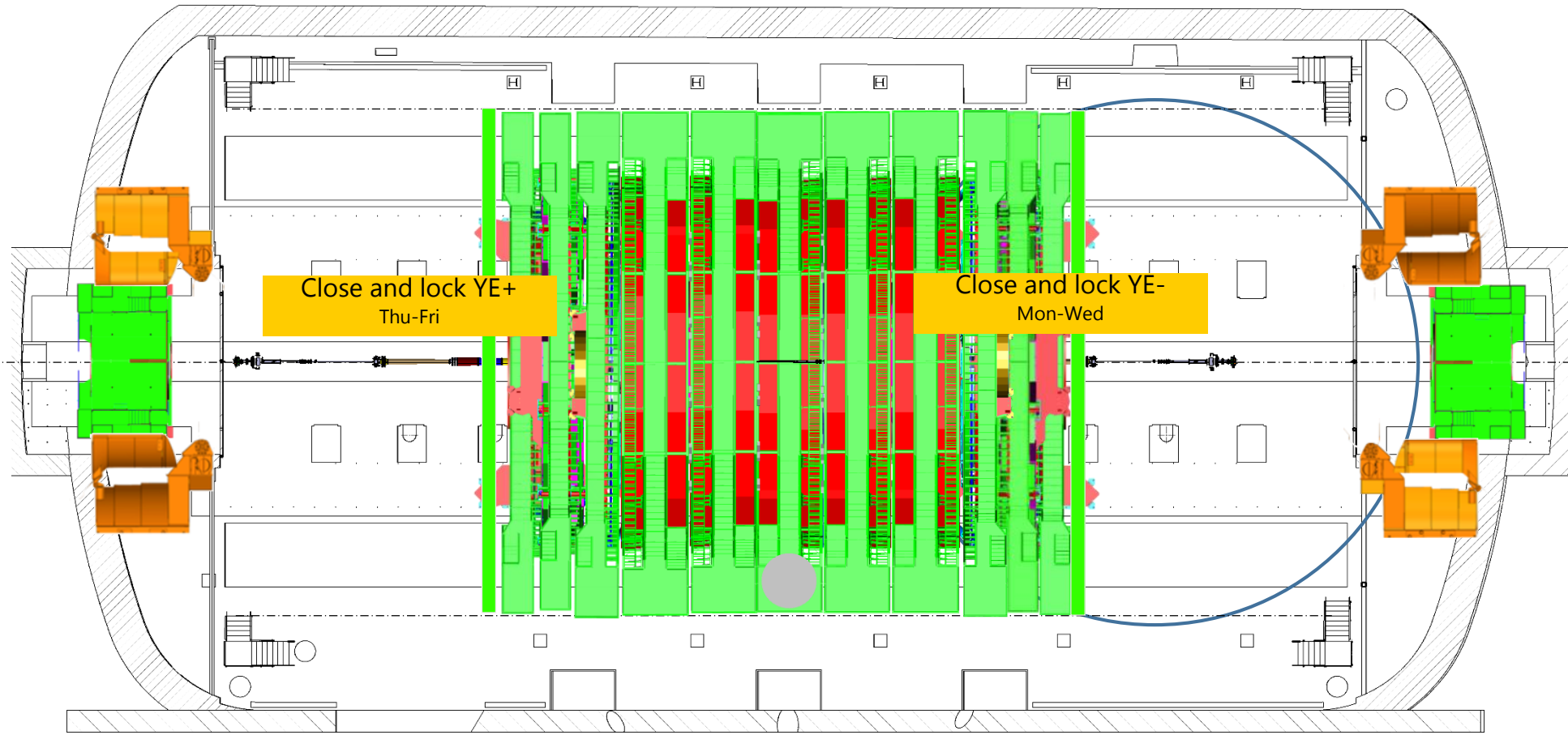
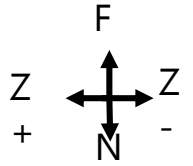

5m





Cryo.	■	EL power	■	Water cool.	■	Database	■
IT	■	Magnet	■	C6F14	■	Gas	■
SL. 0	GEM	ECAL	ZEC	DT+ RB	Survey	TE-VSC	GS Dept
CP. 0	TOTEM	CMX	CSC RE	TK PIX	HCAL	EN Dept	<b>RP</b>

PX56 Plug  
CLOSED

TX54 Plug  
CLOSED

2021

January - Week 3

Crane

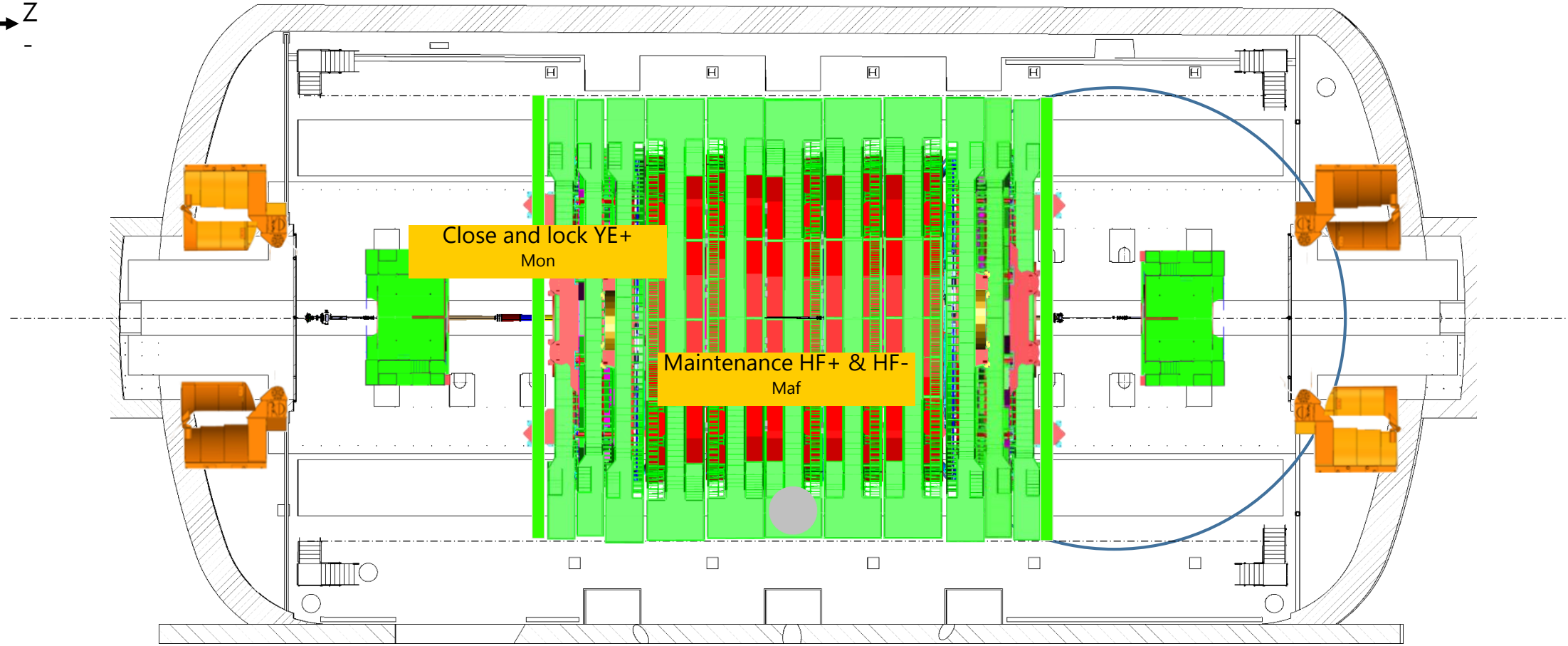
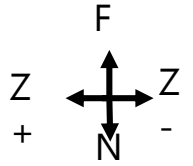

5m



Cryo.	■	EL power	■	Water cool.	■	Database	■
IT	■	Magnet	■	C6F14	■	Gas	■
SL. 0	GEM	ECAL	ZEC	DT+ RB	Survey	TE-VSC	GS Dept
CP. 0	TOTEM	CMX	CSC RE	TK PIX	HCAL	EN Dept	<b>RP</b>

PX56 Plug  
CLOSED

TX54 Plug  
CLOSED

2021

January - Week 4

Crane

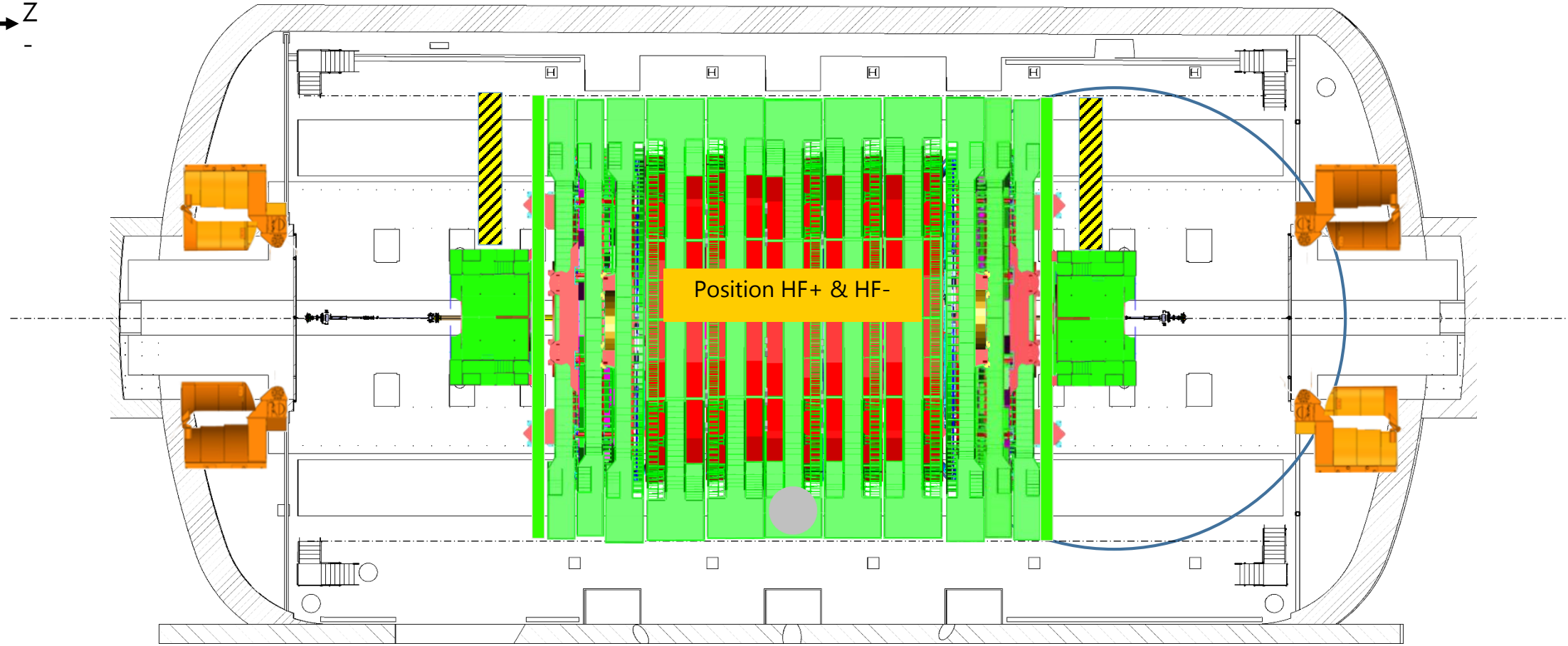
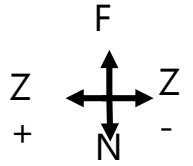

5m



Crane

Cryo.	■	EL power	■	Water cool.	■	Database	■
IT	■	Magnet	■	C6F14	■	Gas	■
SL. 0	GEM	ECAL	ZEC	DT+ RB	Survey	TE-VSC	GS Dept
CP. 0	TOTEM	CMX	CSC RE	TK PIX	HCAL	EN Dept	<b>RP</b>

PX56 Plug CLOSED
TX54 Plug CLOSED

2021

February - Week 5

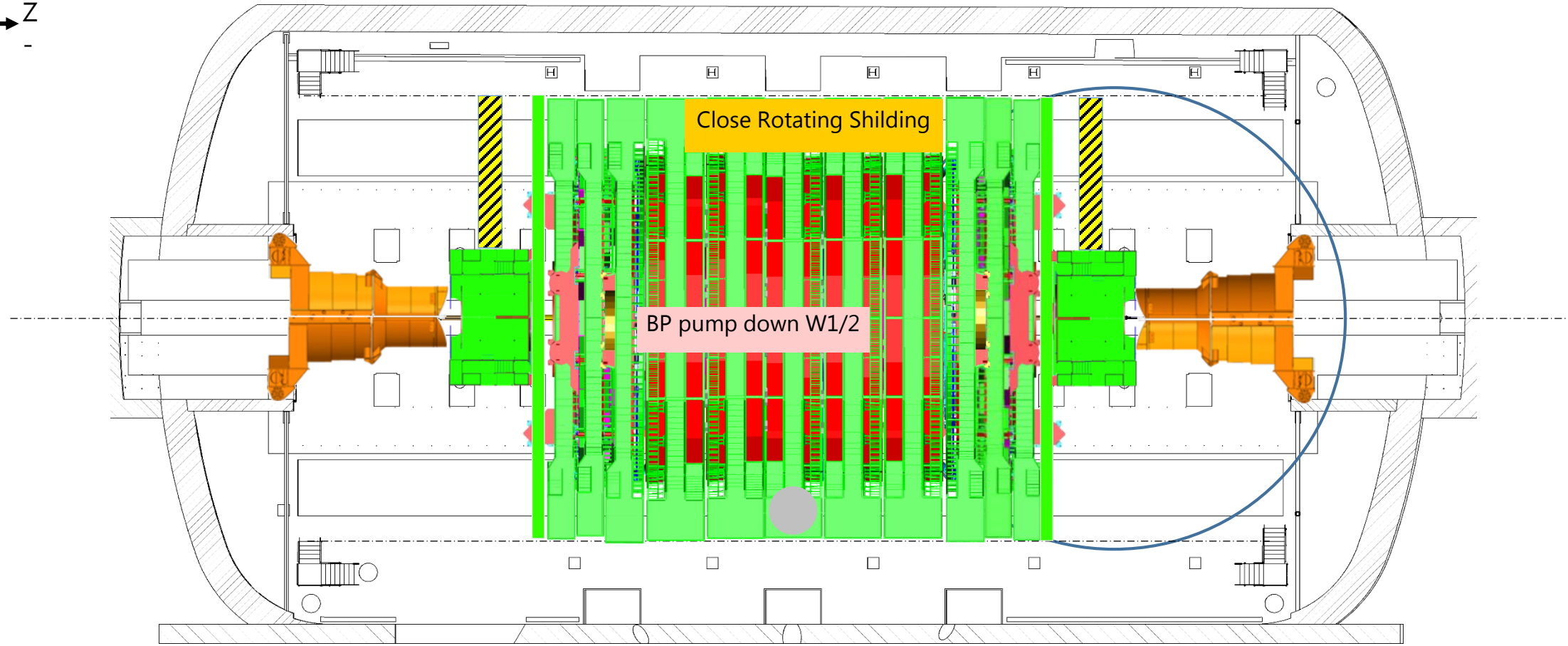
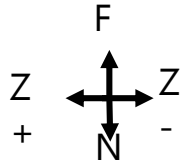

5m



Crane

Cryo.	■	EL power	■	Water cool.	■	Database	■
IT	■	Magnet	■	C6F14	■	Gas	■
SL. 0	GEM	ECAL	ZEC	DT+ RB	Survey	TE-VSC	GS Dept
CP. 0	TOTEM	CMX	CSC RE	TK PIX	HCAL	EN Dept	<b>RP</b>

PX56 Plug  
CLOSED

TX54 Plug  
CLOSED

2021

February - Week 6

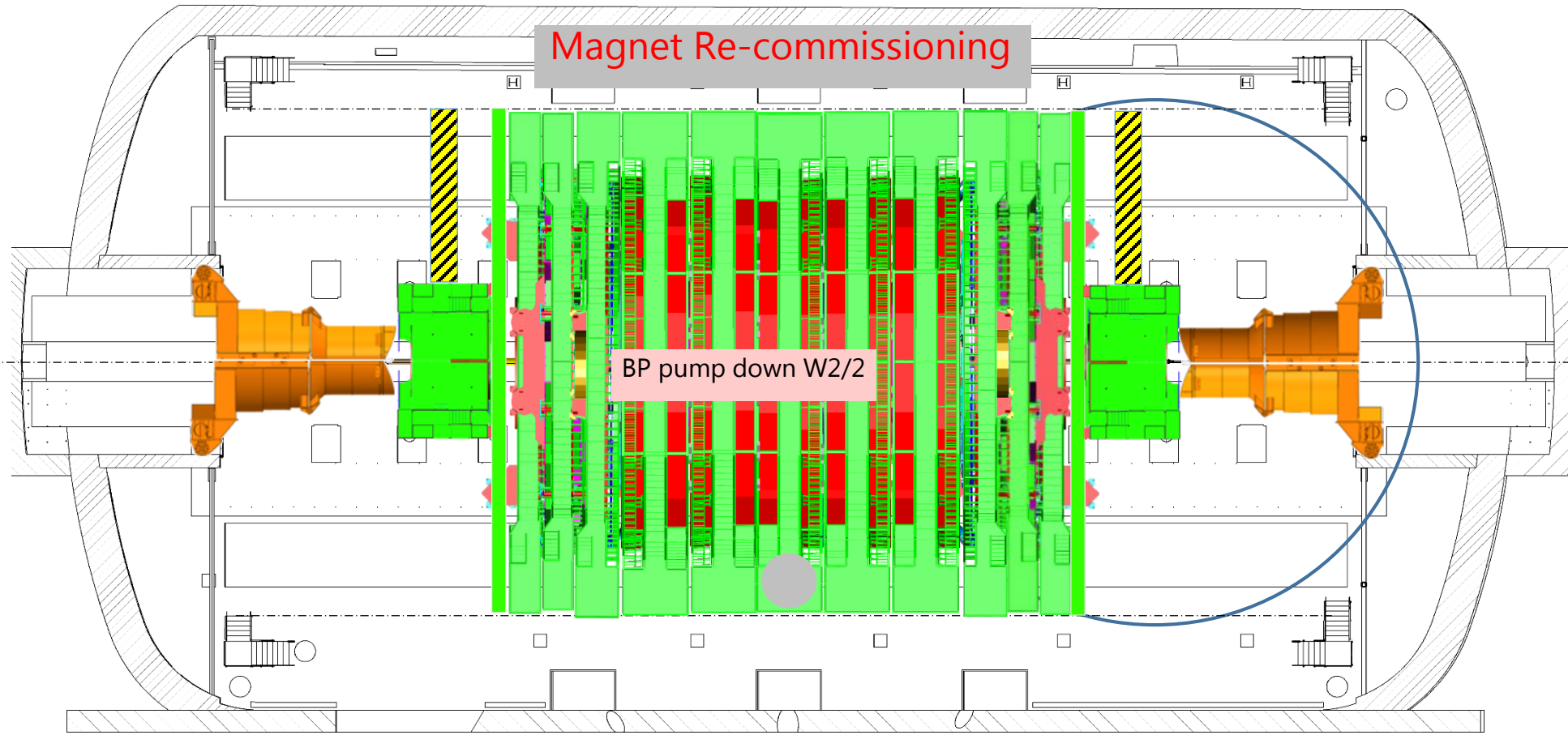
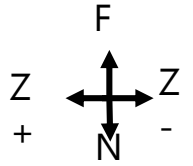

5m



Crane

Cryo.	■	EL power	■	Water cool.	■	Database	■
IT	■	Magnet	■	C6F14	■	Gas	■
SL. 0	GEM	ECAL	ZEC	DT+ RB	Survey	TE-VSC	GS Dept
CP. 0	TOTEM	CMX	CSC RE	TK PIX	HCAL	EN Dept	<b>RP</b>

PX56 Plug  
CLOSED

TX54 Plug  
CLOSED

2021

February - Week 7

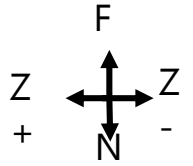

Ready for re-commissioning with Beam

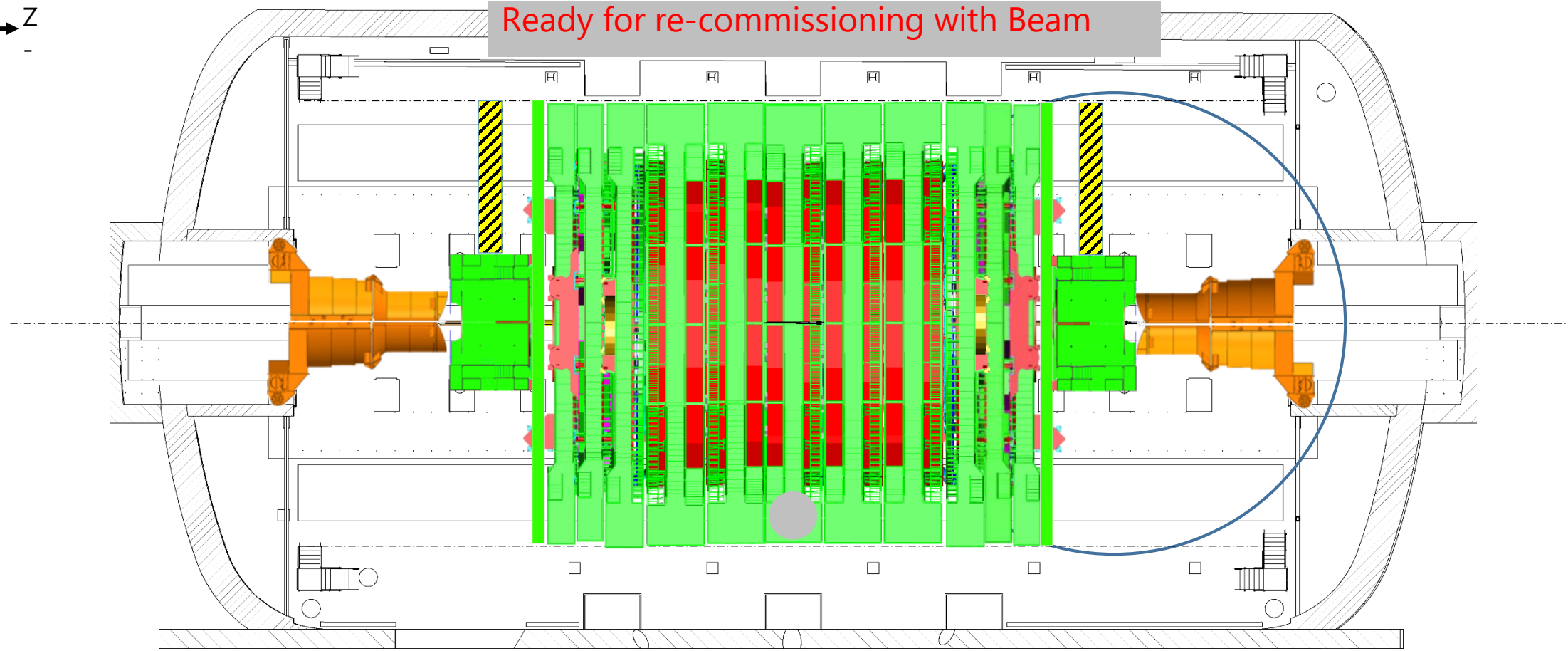

5m





Cryo.	■	EL power	■	Water cool.	■	Database	■
IT	■	Magnet	■	C6F14	■	Gas	■
SL. 0	GEM	ECAL	ZEC	DT+ RB	Survey	TE-VSC	GS Dept
CP. 0	TOTEM	CMX	CSC RE	TK PIX	HCAL	EN Dept	<b>RP</b>

PX56 Plug  
CLOSED

TX54 Plug  
CLOSED

2021

February - Week 08

Crane

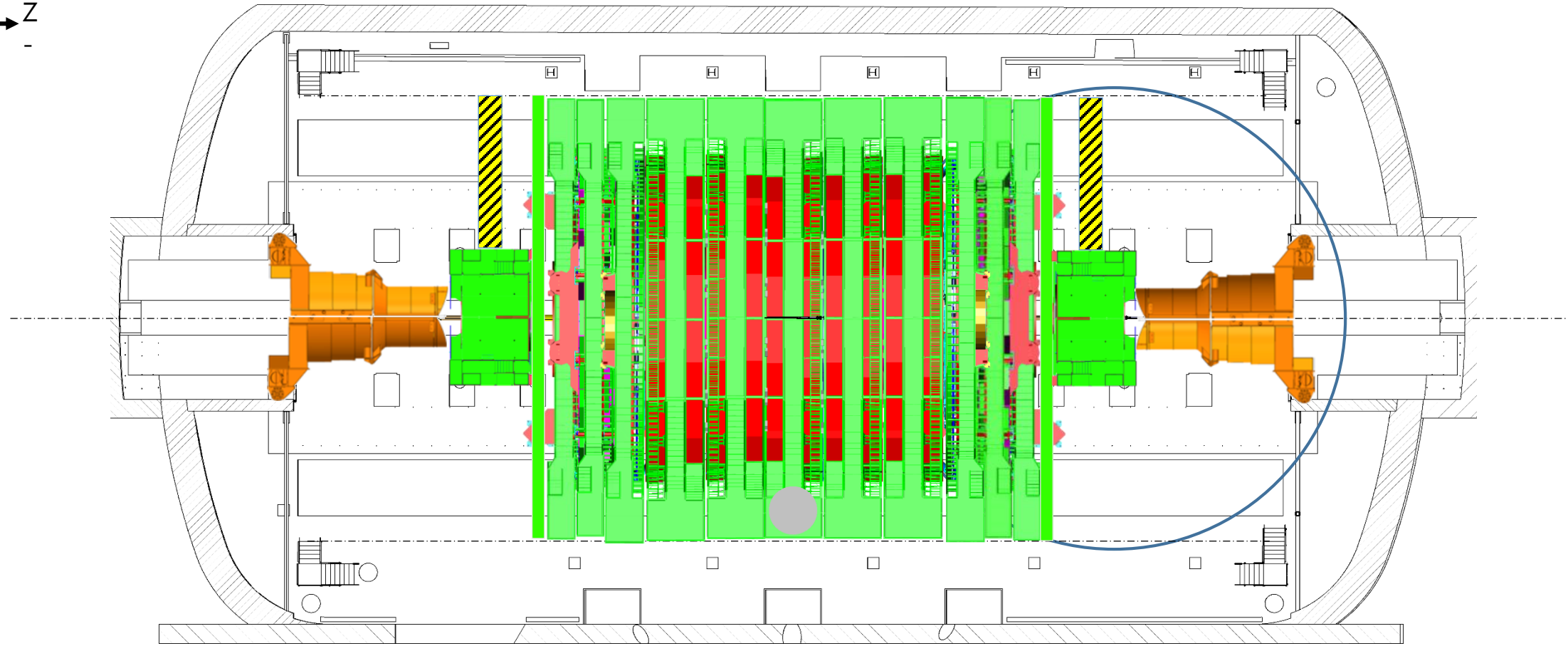
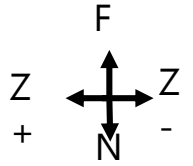

5m



Crane

Cryo.	█	EL power	█	Water cool.	█	Database	█
IT	█	Magnet	█	C6F14	█	Gas	█
SL. 0	GEM	ECAL	ZEC	DT+ RB	Survey	TE-VSC	GS Dept
CP. 0	TOTEM	CMX	CSC RE	TK PIX	HCAL	EN Dept	<b>RP</b>

PX56 Plug CLOSED	2021
TX54 Plug CLOSED	March - Week 09

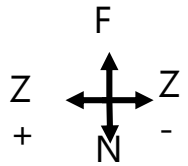

Last week of LS2

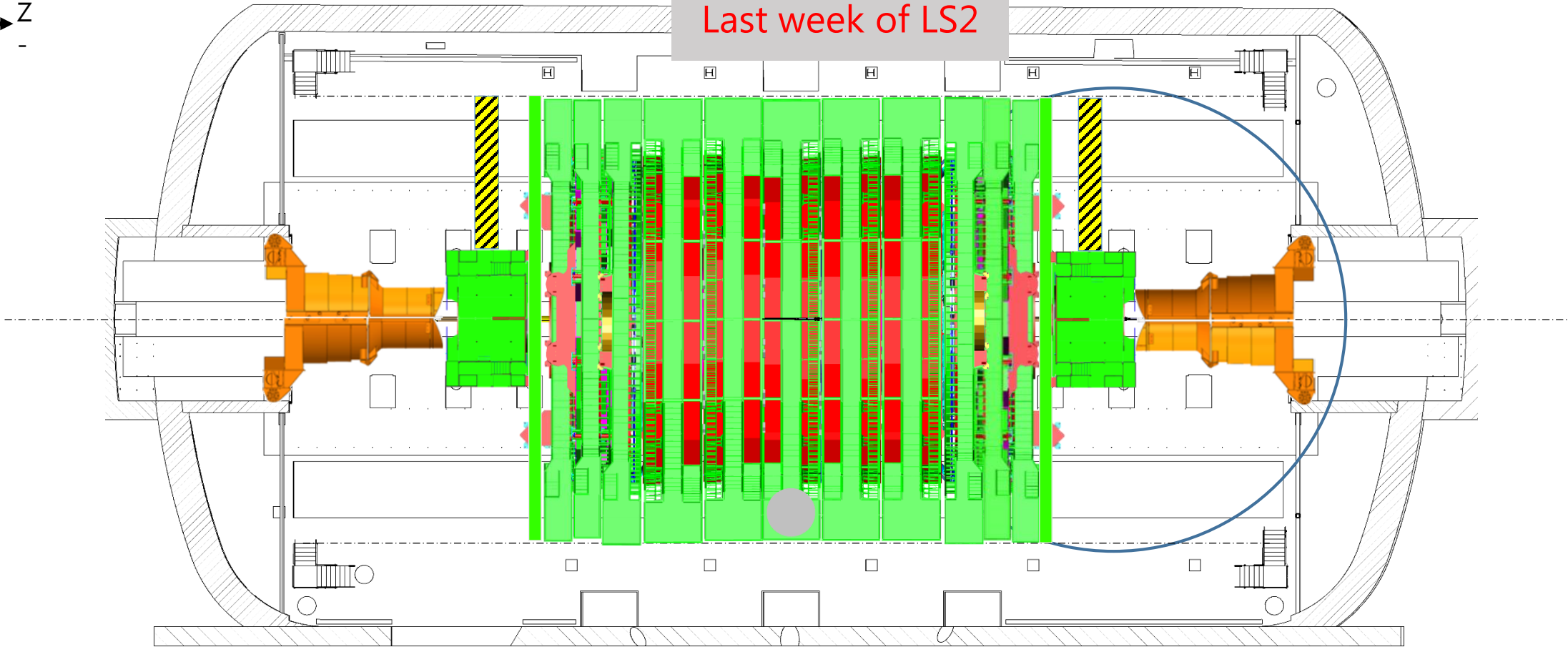

5m