

From The Industry Leader

Get peace of mind with protection against sophisticated attacks.
CrowdStrike®

email: tony@lathes.co.uk

[Home](#) [Machine Tool Archive](#) [Machine-tools Sale & Wanted](#)
[Machine Tool Manuals](#) [Catalogues](#) [Belts](#) [Books](#) [Accessories](#)

Graziano SAG 12 Lathe - Early, Middle and Late

[Graziano Home Page](#)

[Graziano SAG 12 Lathes](#) [Graziano SAG 508, SAG 230, SAG 22 and SAG 20 Lathes](#)

[Graziano SAG 14 & 180 Details](#) [Graziano SAG 22n, 22nr and 22nrf Lathes](#)

[Graziano SAG 17 Lathe](#)

**Instruction, Maintenance & Parts
Manuals for many SAG lathes [are available](#)**

Built from the 1950s until the early 1980s, all the Graziano SAG12 lathes had a centre height of 6 inches (152 mm) and a capacity between centres of 32 inches (812 mm). Both shared the same number of thread pitches, these being 30 Whitworth (inch) from 6 to 46 t.p.i and 60 metric from 0.75 to 5.75 mm and the same power sliding and surfacing feed rates, 60 from 0.002" to 0.0188" (0.05 to 0.5 mm) per spindle revolution and at half that rate for cross feed. The eight spindle speeds of 80 to 2000 r.p.m. were also common. Mechanically, the first two versions were almost identical, only the electrical controls undergoing a modest enhancement.

By the late 1970s, the last version - the SAG 12S - was in production. This model was heavily revised, though it did share all the dimensional and technical features of the earlier versions but was styled in an up-to-date angular form. One of the main changes was to the drive system, with the previous 3 h.p. motor replaced by a 4 h.p. one and the range of set speeds being replaced by the option of two continuously-variable low and high rates. The first option was 55 to 360 r.p.m. and 310 to 2000 r.p.m. and the second 80 to 470 r.p.m. and 470 to 2600 r.p.m. The drive system chosen was of the traditional expanding-and-contracting pulley type with changes in ratio made an electric motor causing the pulleys to open and close. Screwcutting and power sliding and surfacing feeds were also altered, the Whitworth pitches being reduced to 30 in number but spanning the same 6

to 46 t.p.i. The Metric pitches were likewise halved in number but still ran from 0.75 to 5.75 mm. Power sliding and surfacing feeds remained as before, being 60 in number and running from (a corrected) 0.0019 to 0.23 inches were spindle revolution with the cross feed at half those rates. The full specification for all models can be found below.



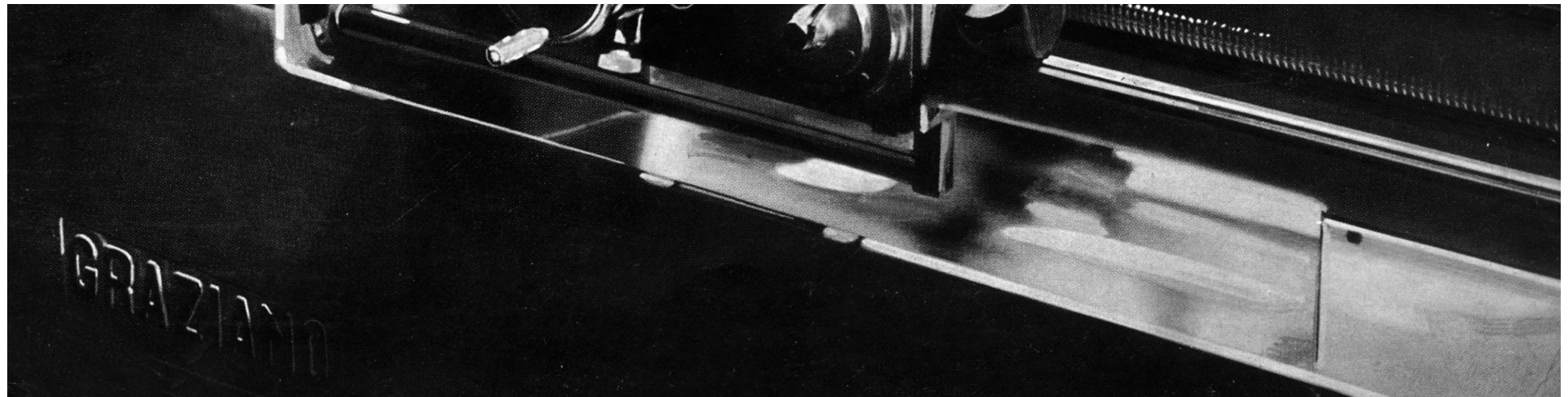

THE « SAG 12 », LATHE

...With a view to completing the range of their center lathes, which have met with considerable success on both the home and international markets, the SOC. GRAZIANO have designed the new « SAG 12 » model featuring all the requisites necessary to comply with the requirements of industry and, particularly, of **the vocational schools as anticipated in the new school regulations**. Actually the « SAG 12 » model meets the typical requirements of such schools owing to the changes made to the controls in order to simplify handling of the machine, whilst at the same time maintaining and increasing the universal efficiency of the lathe.

THE BASEMENT forms, with the headstock and feedbox, a monolithic unit designea to obtain damping of vibrations caused by the tools during operations.

THE BED, in Meehanite cast-iron and secured to the basement, maintains the same features as the SAG Lathes that constitute one of the most important innovations of all-g geared lathes, i. e. guides lowered in respect of the tailstock base and protected by two steel plates, a wide deep natural gap made

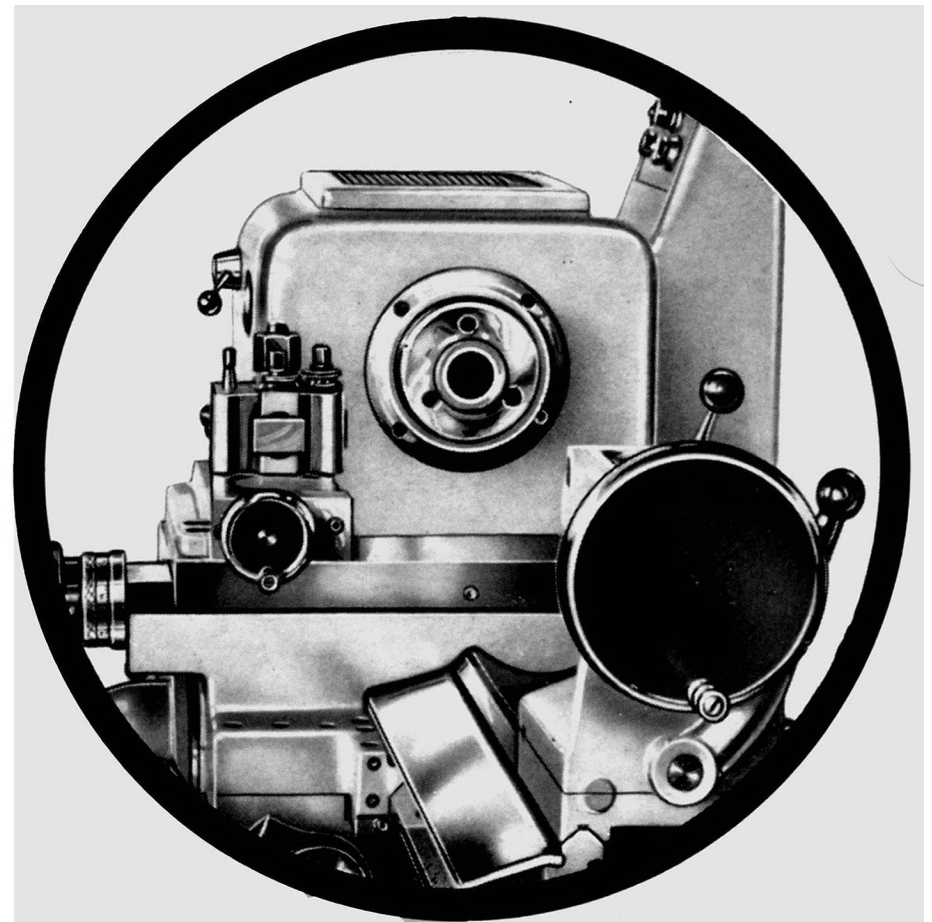

by the stop of the tailstock at some distance from the head.

SPINDLE: The special steel spindle is hardened and fitted on high precision tapered roller bearings. In the front part a special type bearing is fitted with a double row of opposed rollers, a single piece outer ring and inner cages adjustable for take-up of slack. In the rear part the outer ring is preloaded by a set of springs to compensate elongation due to heating. By this arrangement we can guarantee half of the usual Schlesingen tolerances and exceptional precision of work. Lubrication of the bearings is performed by an appropriate pump. The filter is easily disassembled from the outside for cleaning purposes and it prevents the entry of any swarf in the bearings. To insert the self-centering chuck into the spindle a CAM-LOCK D1-4" coupling has been applied. This ensures interchangeability on all lathes without special flanges and the utmost rapidity and safety in assembling and disassembling the self-centering chucks. Furthermore, a remarkable innovation concerning this part of the machine is represented by a **single selector located on the apron, by which reverse spindle rotation and speed control is obtained by inserting it into the electromagnetic friction change.**

The feed reverse unit is also fitted in the headstock.

THE FEED BOX is entirely enclosed. A handwheel controls a cam that affords ten positions. With two more levers 30 Whitworth and 30 Metric pitches are obtained without having to change any of the gears. All the gears are of treated steel and they rotate in an oil bath. They run on tempered shafts with splined and ground profiles.

THE APRON is box shaped and has an oil level providing a constant bath for the gears; all the components are splash lubricated. A clutch device disengages all feeds should excessive stress occur.

THE TAIL STOCK is well dimensioned and provided with

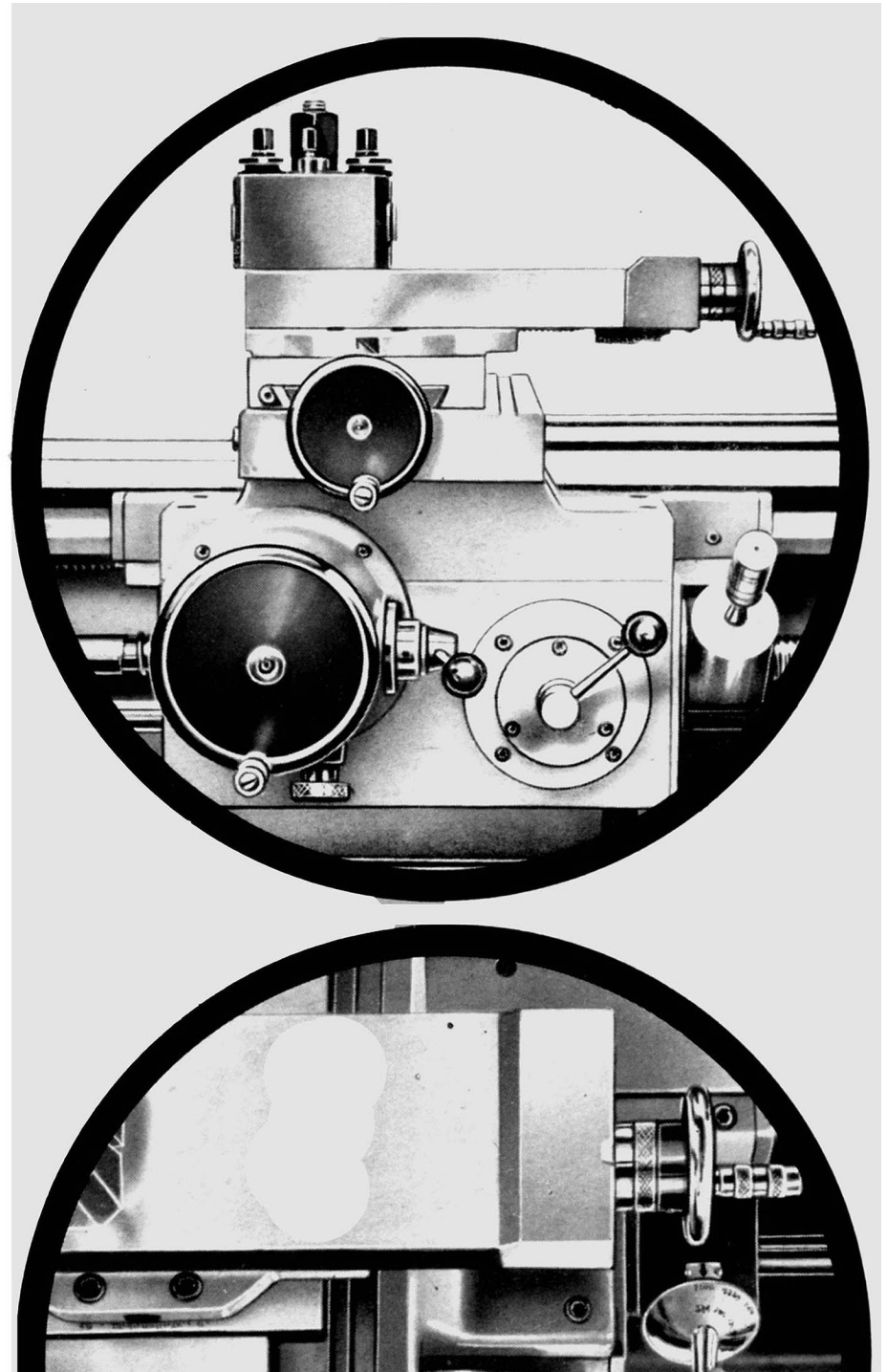

THE TAILSTOCK is well dimensioned and provided with an accurate hardened sleeve and quick lever locking. It protrudes considerably to enable the matching of short workpieces without excessive projecting of the sleeve.

It can be adjusted transversally for the machining of slightly tapered workpieces. A graduated ring is applied for depth gauging.

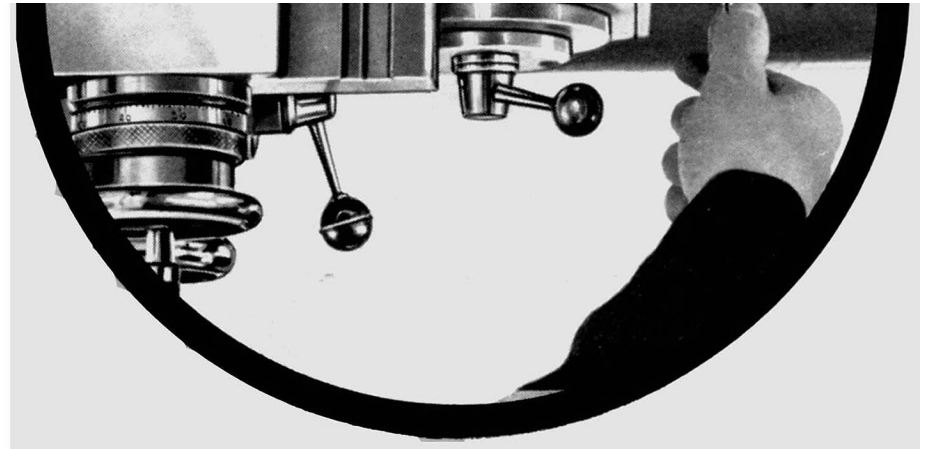

△ ×

07:02:09

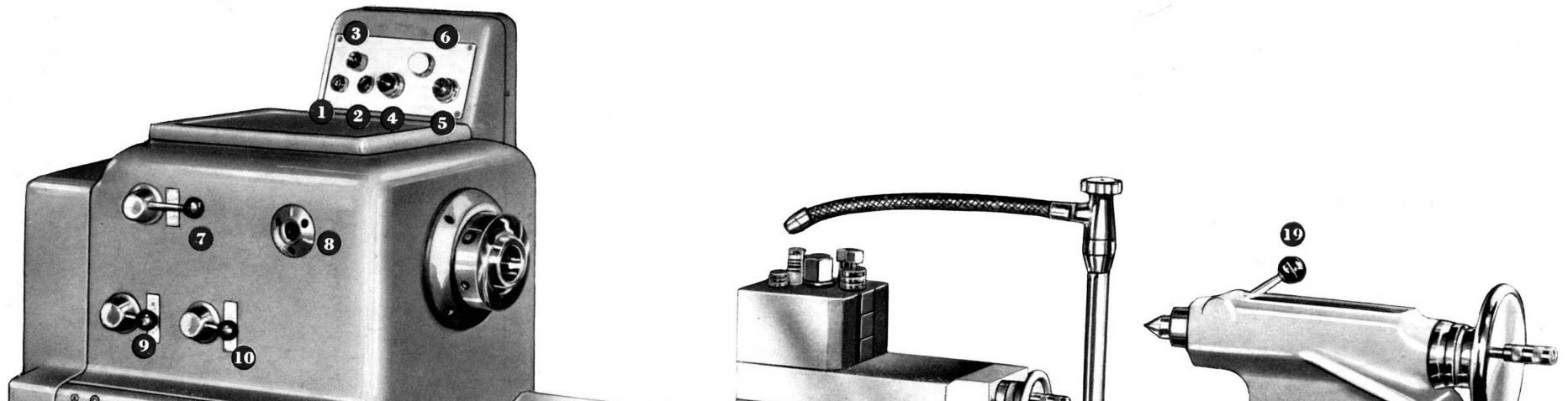

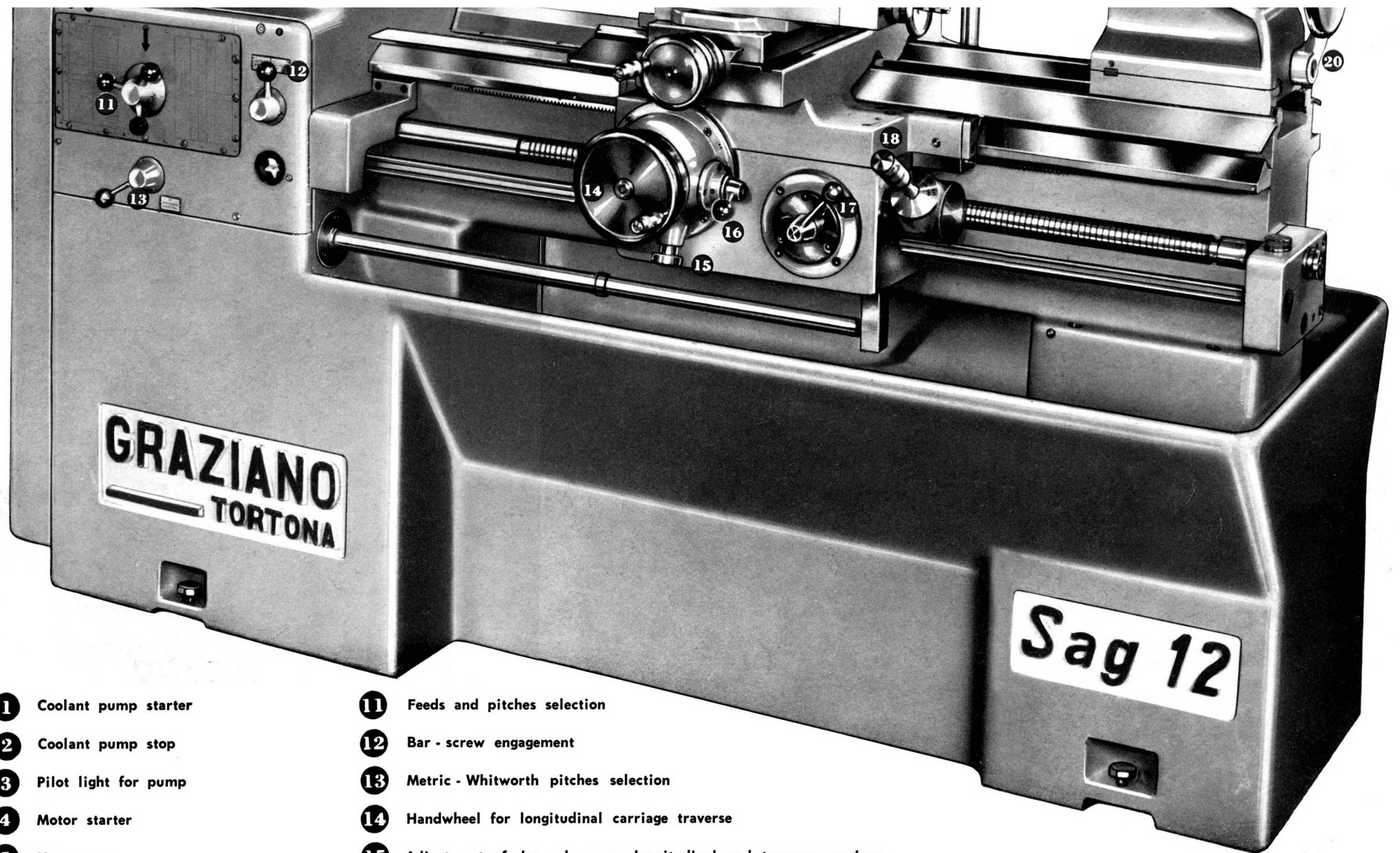

- | | | | |
|----|--|----|---|
| 1 | Coolant pump starter | 11 | Feeds and pitches selection |
| 2 | Coolant pump stop | 12 | Bar - screw engagement |
| 3 | Pilot light for pump | 13 | Metric - Whitworth pitches selection |
| 4 | Motor starter | 14 | Handwheel for longitudinal carriage traverse |
| 5 | Motor stop | 15 | Adjustment of dog release on longitudinal and traverse carriage |
| 6 | Pilot light for motor | 16 | Automatic longitudinal and traverse feeds selector |
| 7 | Quick - slow action | 17 | Lead screw engagement lever |
| 8 | Oil delivery pump and filter pilot light | 18 | Spindle rotation speed and reverse selector |
| 9 | Lead screw and bar rotation reverse | 19 | Tailstock sleeve clamping |
| 10 | Feed and pitch ratio selection | 20 | Tailstock to bed clamping |

SAG 12

GENERAL FEATURES

Height of centers over bed 6"
Distance between centers 32"
Swing over carriage 6 1/2"
Swing over natural gap 17 5/16"

B E D

Width of bed 9 5/8"

HEADSTOCK

Spindle bore 1 5/8"
Cone Morse N.° 5
Spindle nose CAM-LOCK D1-4"

S P E E D

Number of speeds 8
Range r.p.m. from 80 to 2000

FEEDS AND THREADS

60 longitudinal feeds from .0023 to .0188
60 traverse feeds » .0011 to .0094
30 Whitworth pitches » 46 to 6 thread/inch
30 Metric pitches » 0,75 to 5,75 mm
30 Modular pitches » 0,375 to 2,875 mm
30 Pitch » 93 to 12
Lead screw pitch 4 thread/inch

CROSS CARRIAGE

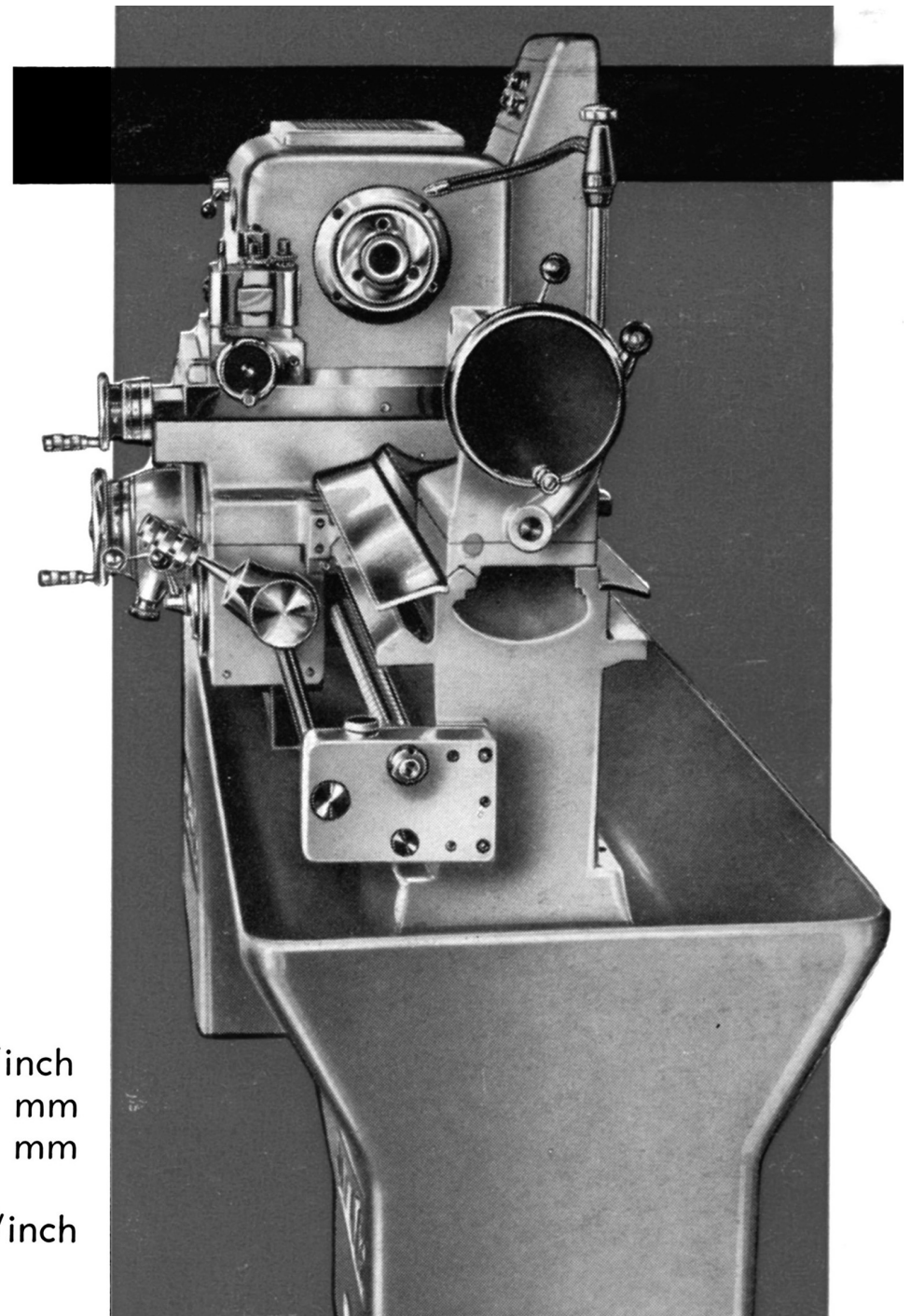

Length $1 \frac{3}{16}''$
Width $5 \frac{7}{8}''$
Maximum travel $6 \frac{5}{16}''$

TOOL POST SADDLE

Length $9 \frac{5}{8}''$
Width $3 \frac{15}{16}''$
Maximum total travel $4 \frac{5}{16}''$
Rotation angle 360°
Maximum tool section $\frac{3}{4}''$

TAILSTOCK

Sleeve bore 1.177
Length of sleeve $8 \frac{3}{4}''$
Maximum sleeve travel $5 \frac{11}{16}''$
Cone Morse N.° 3
Support length on bed $8 \frac{5}{8}''$

MOTOR

3 HP
Approximate net weight 2208 lbs

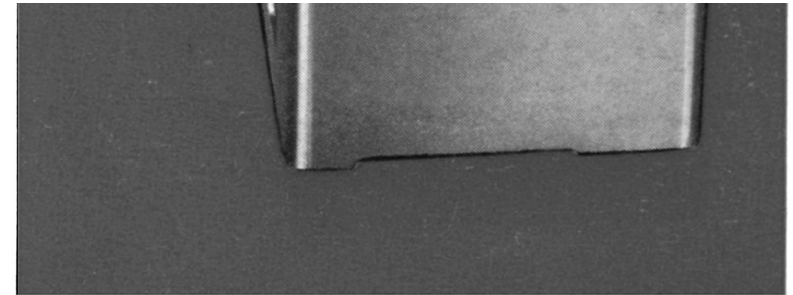

soc. GRAZIANO & C. TORTONA (Italia)

VIA BERTARINO, 8 - TEL. 81.267 - 83.064

graziano

SAG 12

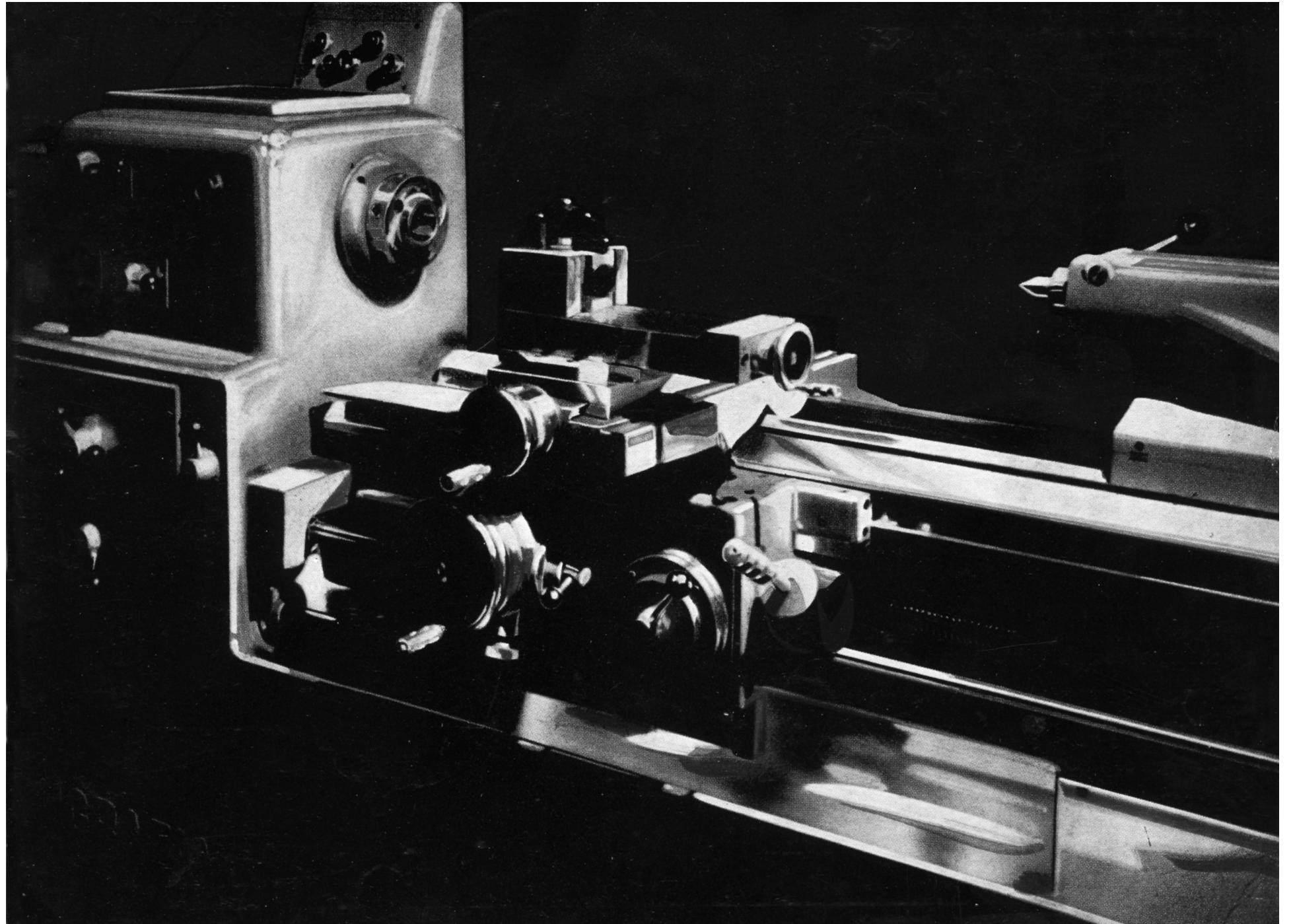

THE SAG 12 LATHE

... With a view to completing the range of their center lathes, which have met with considerable success on both the home and international markets, the SOC. GRAZIANO have designed the new «SAG 12» model featuring all the requisites necessary to comply with the requirements of industry and, particularly, of **the vocational schools as anticipated in the new school regulations**. Actually the «SAG 12» model meets the typical requirements of such schools owing to the changes made to the controls in order to simplify handling of the machine, whilst at the same time maintaining and increasing the universal efficiency of the lathe.

THE machine base forms, with the headstock and feedbox, a monolithic unit design to dampen of vibrations caused by the tools during operations.

THE BED, in Meehanite cast-iron and secured to the base maintains the same features as the other GRAZIANO Lathes, which constitutes one of the most important innovations of all-g geared lathes, i.e. guides lowered in respect of the tailstock base and protected by two steel

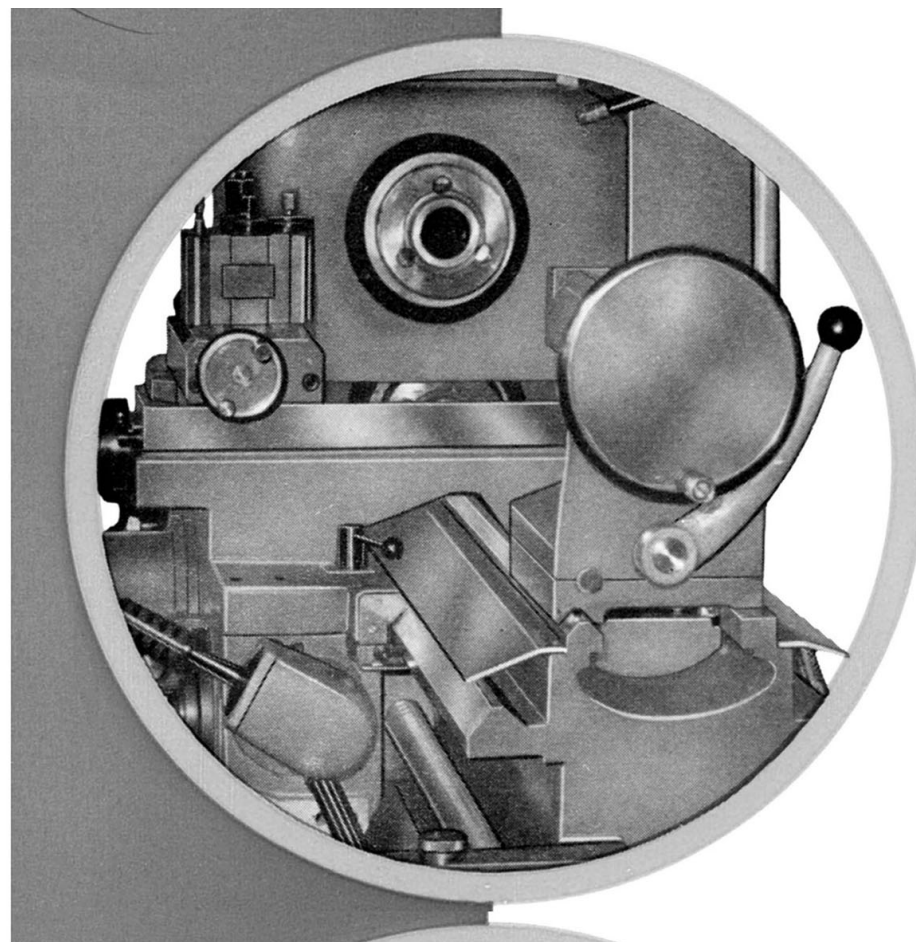

plates, a wide deep Natural gap made by the stop of the tailstock at some distance from the head.

SPINDLE: The special steel spindle is hardened and fitted on high precision tapered roller bearings. In the front part a special type bearing is fitted with a double row of opposed rollers, a single piece outer ring and inner cages adjustable for take-up of slack. In the rear part the outer ring is preloaded by a set of springs to compensate elongation due to heating. By this arrangement we can guarantee half of the usual Schlesinger tolerances and exceptional precision of work. Lubrication of the bearings is performed by an appropriate pump. The filter is easily disassembled from the outside for cleaning purposes and it prevents the entry of any swarf in the bearings. To insert the self-centering chuck into the spindle a CAM-LOCK D1-4" coupling has been applied. This ensures interchangeability on all lathes without special flanges and the utmost rapidity and safety in assembling and disassembling the self-centering chucks. Furthermore, a remarkable innovation concerning this part of the machine is represented by a **single selector located on the apron, by which reverse spindle rotation and speed control is obtained by inserting it into the electromagnetic friction change.**

The feed reverse unit is also fitted in the headstock.

THE FEED BOX is entirely enclosed. A handwheel controls a cam that affords ten positions. With two more levers 30 Whitworth and 30 Metric pitches are obtained without having to change any of the gears. All the gears are of treated steel and they rotate in an oil bath. They run on tempered shafts with splined and ground profiles.

THE APRON is box shaped and has an oil level providing a constant bath for the gears; all the components are splash lubricated. A clutch device disengages all feeds should excessive stress occur.

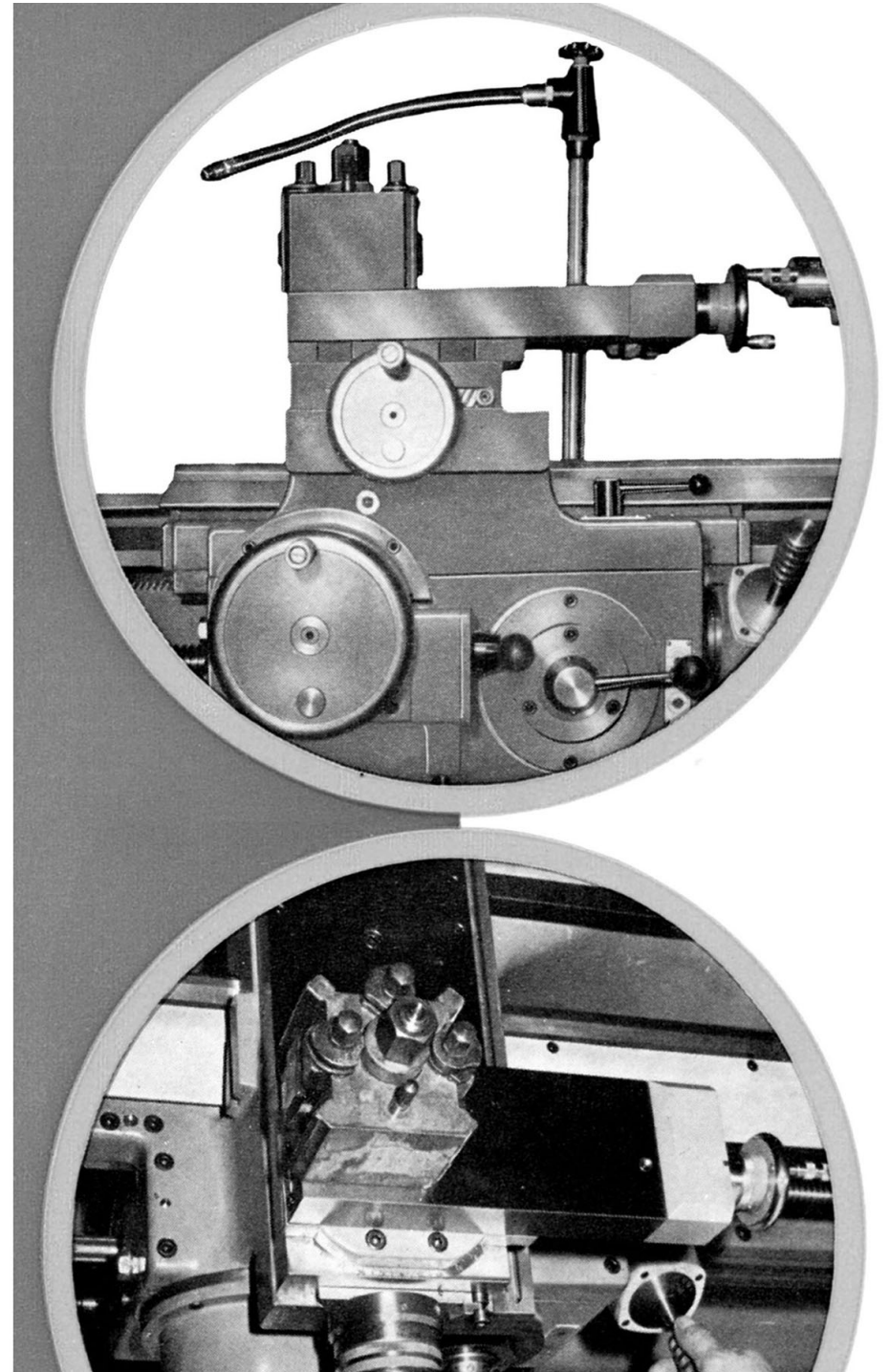

THE TAILSTOCK is well dimensioned and provided with an accurate hardened sleeve and quick lever locking. It protrudes considerably to enable the matching of short workpieces without excessive projecting of the sleeve.

It can be adjusted transversally for the machining of slightly tapered workpieces. A graduated ring is applied for depth gauging.

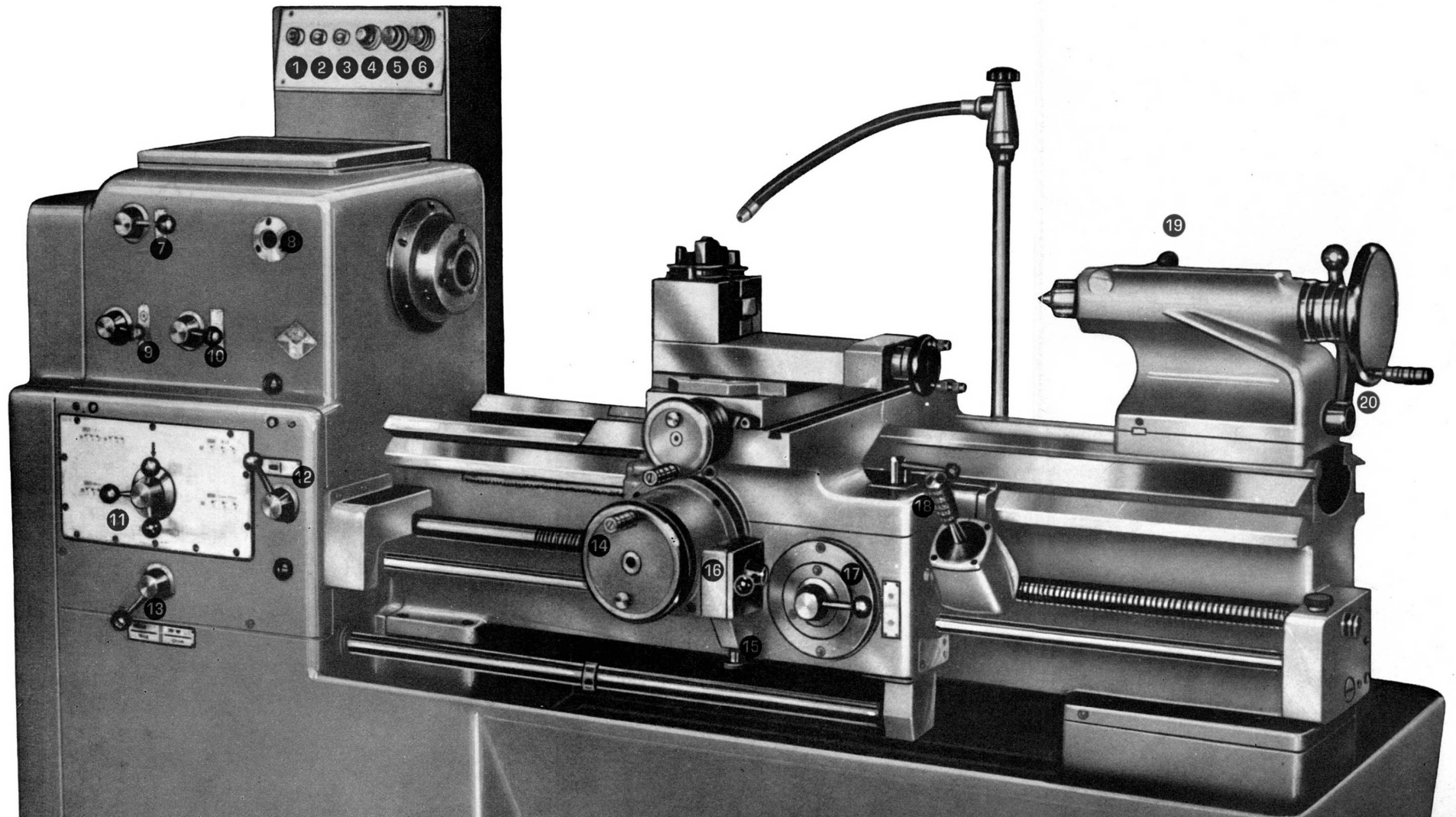
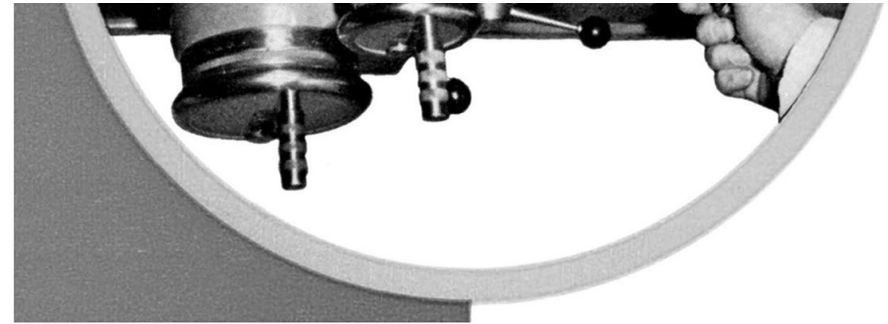

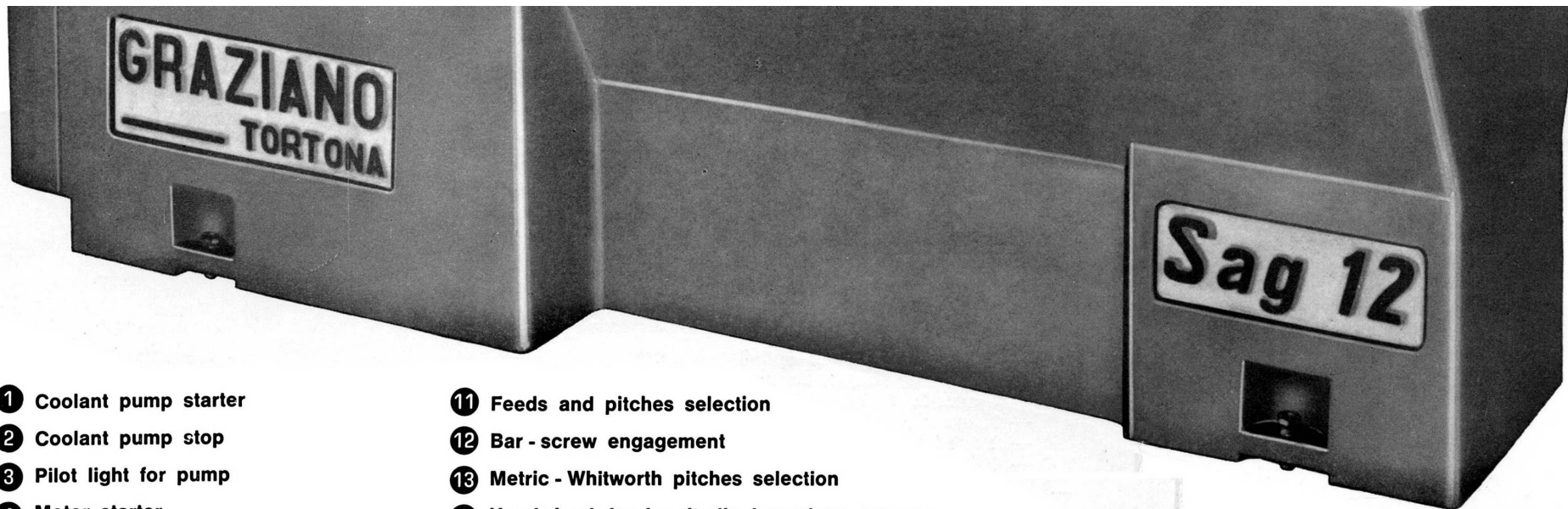

- | | |
|--|---|
| ① Coolant pump starter | ⑪ Feeds and pitches selection |
| ② Coolant pump stop | ⑫ Bar - screw engagement |
| ③ Pilot light for pump | ⑬ Metric - Whitworth pitches selection |
| ④ Motor starter | ⑭ Handwheel for longitudinal carriage traverse |
| ⑤ Motor stop | ⑮ Adjustment of dog release on longitudinal and traverse carriage |
| ⑥ Pilot light for motor | ⑯ Automatic longitudinal and traverse feeds selector |
| ⑦ Quick - slow action | ⑰ Lead screw engagement lever |
| ⑧ Oil delivery pump and filter pilot light | ⑱ Spindle rotation speed and reverse selector |
| ⑨ Lead screw and bar rotation reverse | ⑲ Tailstock sleeve clamping |
| ⑩ Feed and pitch ratio selection | ⑳ Tailstock to be clamping |

SAG 12

GENERAL FEATURES

Height of centers over bed

6"

Distance between centers

32"

Swing over carriage

6 1/2"

Swing over natural gap

17 5/16"

B E D

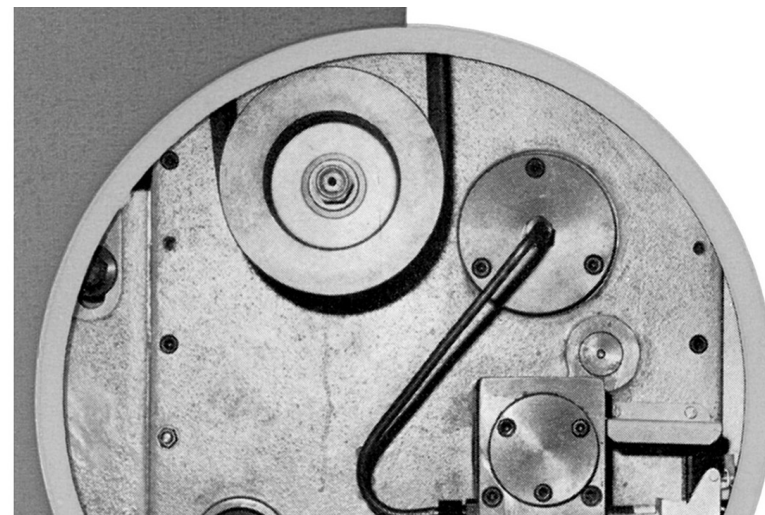

Width of bed

9 5/8"

HEADSTOCK

Spindle bore

1 5/8"

Cone Morse

N.º 5

Spindle nose

CAM-LOCK D1-4"

SPEED

Number of speeds

8

Range r.p.m. from

80 to 2000

FEEDS AND THREADS

60 longitudinal feeds

from .0023 to .0188

60 traverse feeds

» .0011 to .0094

30 Whitworth pitches

» 46 to 6 thread/incl

30 Metric pitches

» 0,75 to 5,75 mn

30 Modular pitches

» 0,375 to 2,875 mn

30 Pitch

» 93 to 12

Lead screw pitch

4 thread/incl

CROSS CARRIAGE

Length

17 5/16"

Width

5 7/8"

Maximum travel

6 5/16"

TOOL POST SADDLE

Length

9 5/8"

Width

3 15/16"

Maximum total travel

4 5/16"

Rotation angle

360°

Maximum tool section

3/4"

TAILSTOCK

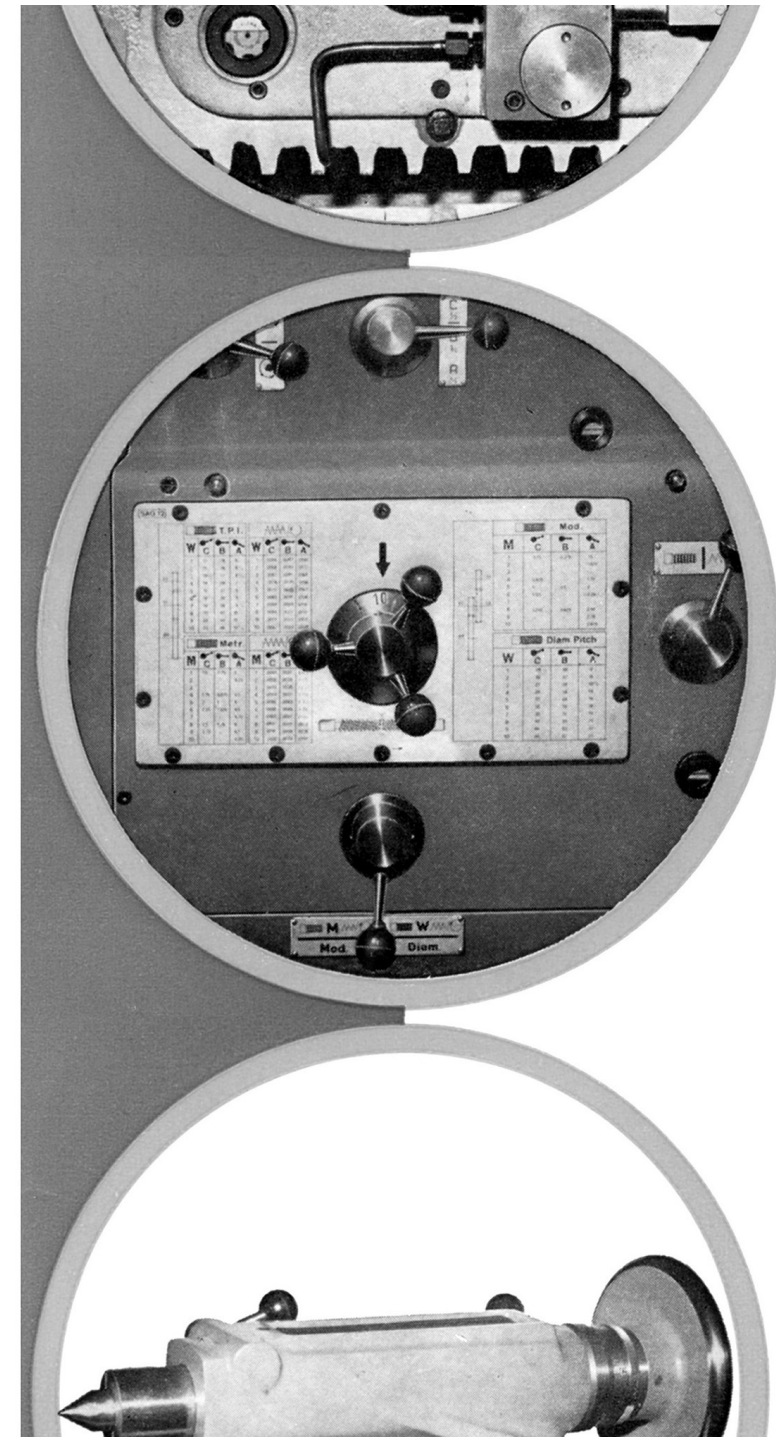

Sleeve bore
Length of sleeve
Maximum sleeve travel
Cone Morse
Support length on bed
MOTOR
Approximate net weight

1.177
8 ³/₄''
5 ¹¹/₁₆
N.º 3
8 ⁵/₈
3 HP
2208 lbs

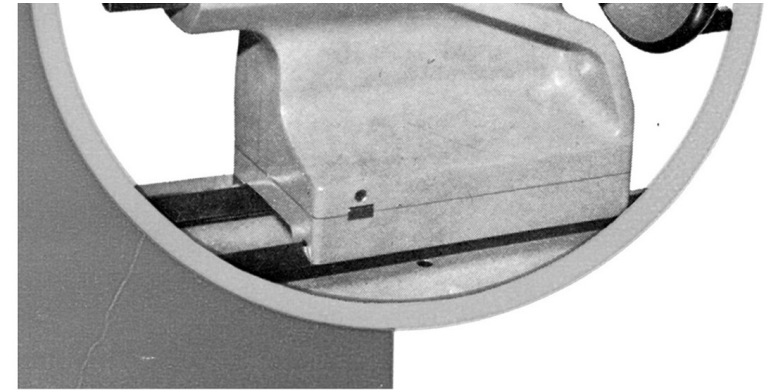

graziano

STC

SAG

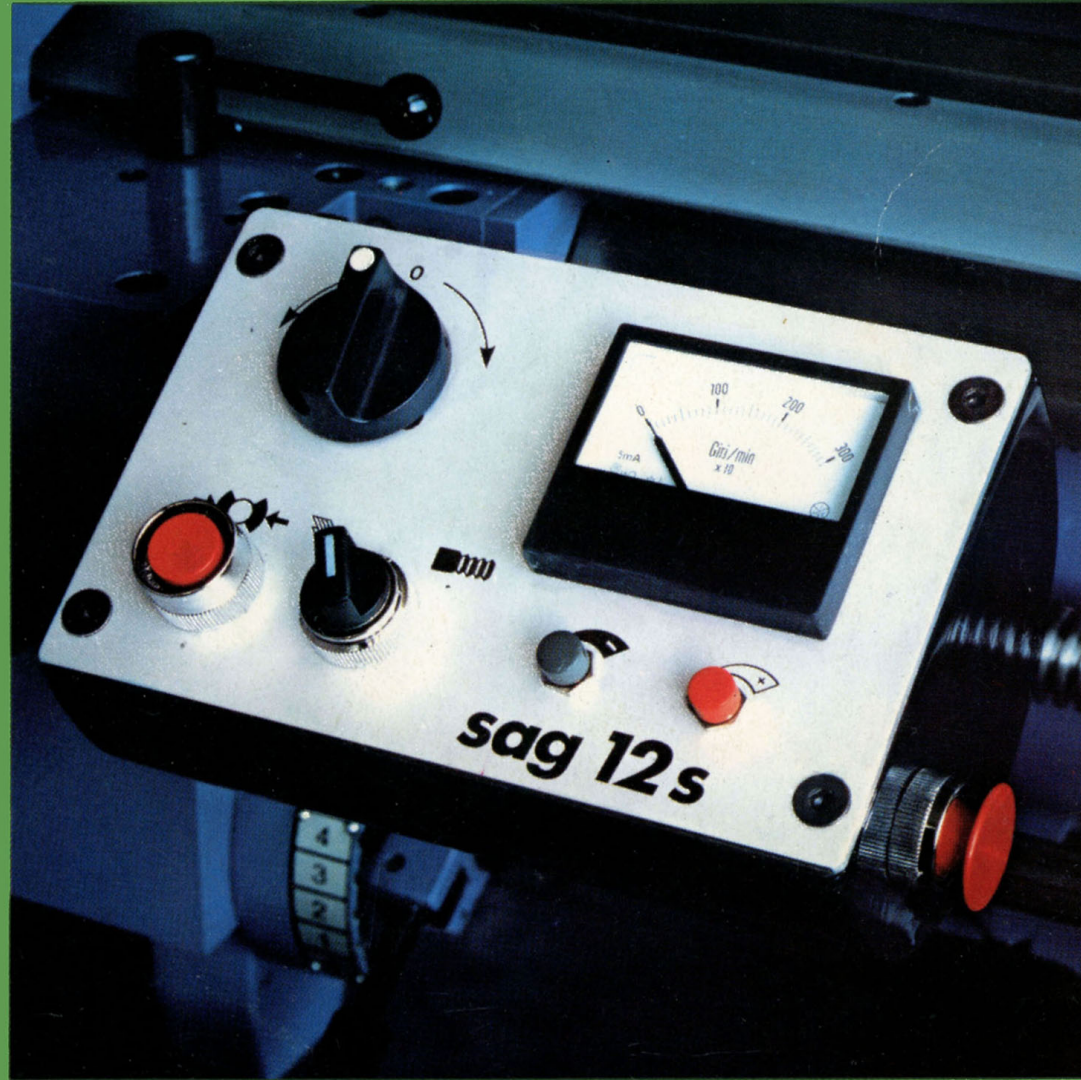

12S

SAG 12S

The Sag 12S has been planned, like all the Sag lathes, in order to get a performance of high efficiency and precision, but above all to allow the operator the easiest and quickest possibility of operating. Its production meets the needs of the industry and also of the vocational schools where the improvements of the controls can be better appreciated because of the simplicity of operation.

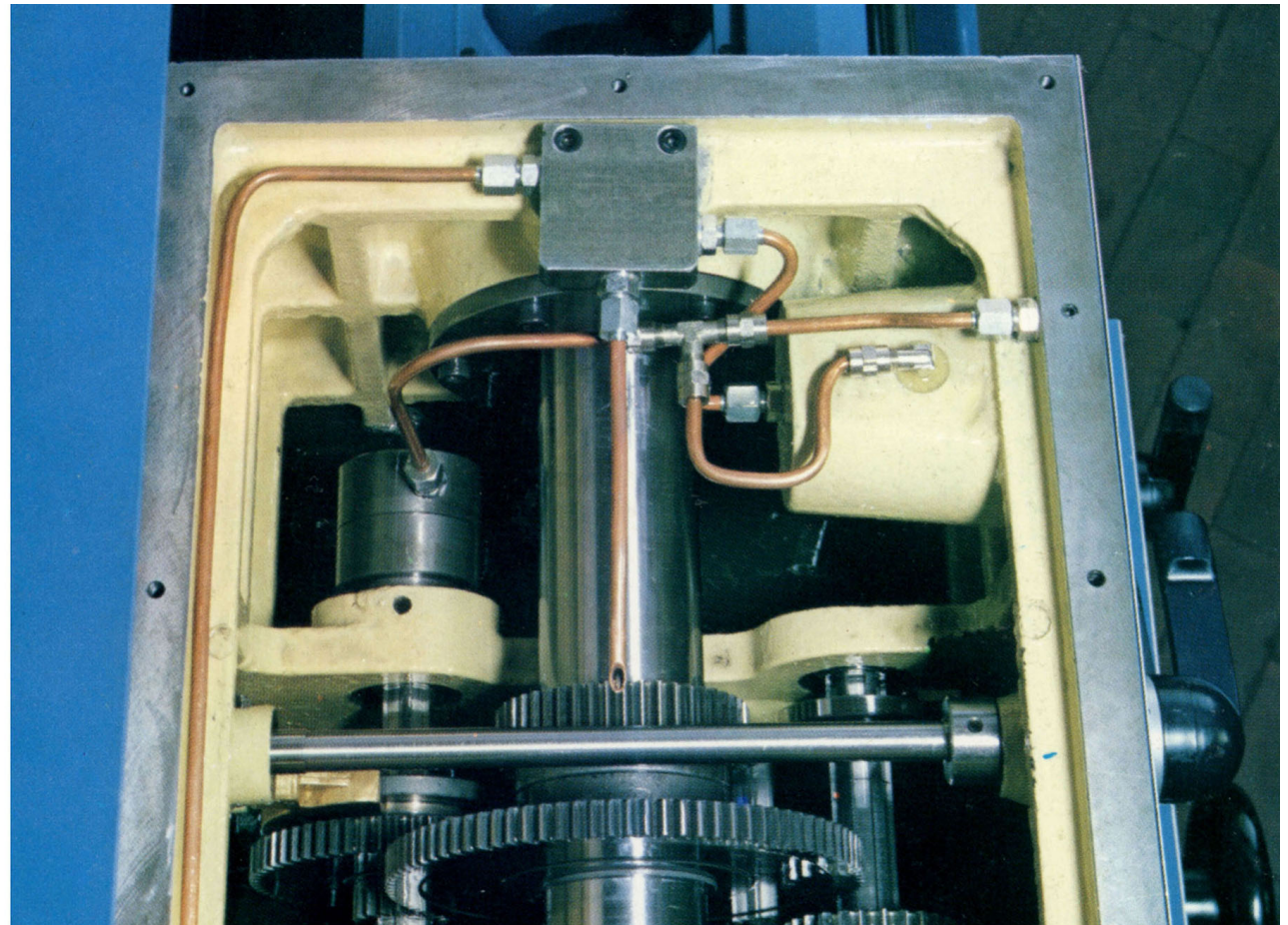

CONTROL CABINET

On one cabinet placed sideways the main carriage, there are the controls of the machine: spindle rotation direction selector, brake push-button, speed variation pushbuttons and the revolution counter.

HEADSTOCK AND CONTROLS

For the ultimate in simplicity, the headstock of the Sag 12 S has just three levers: one for backgears, one for reversing the lead screw and

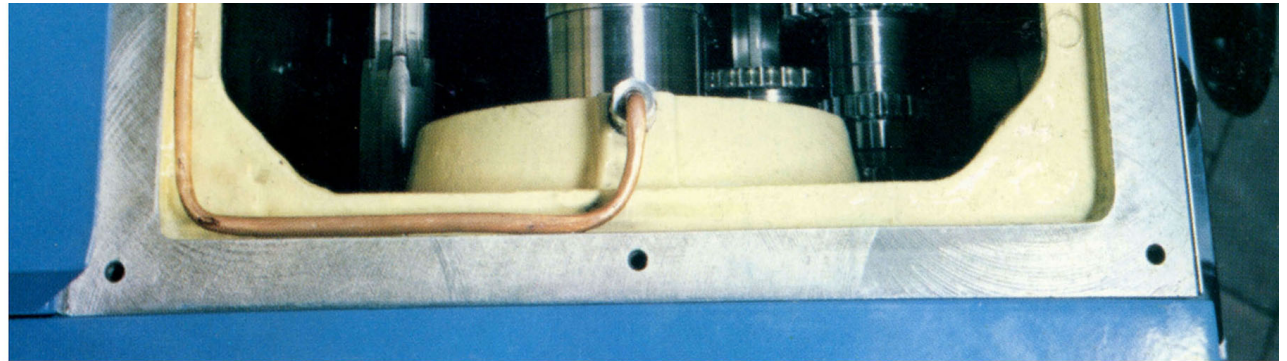

feed rod and the last one for feed and thread selection.

All splines and shafts are chrome-nickel steel, hardened and ground. The spindle in high quality steel is mounted on high precision tapered roller bearings, lubricated under pressure by a filter easily stripped from outside for cleaning.

All gears rotate in a constant oil bath.

The headstock, base and gear box are constructed as a single integral unit which helps to reduce tool vibration.

Cam-lock attack type D1-4''.

This feature insures the interchangeability on all lathes without special faceplates and guarantees the best quickness and reliability in mounting and dismantling the chucks.

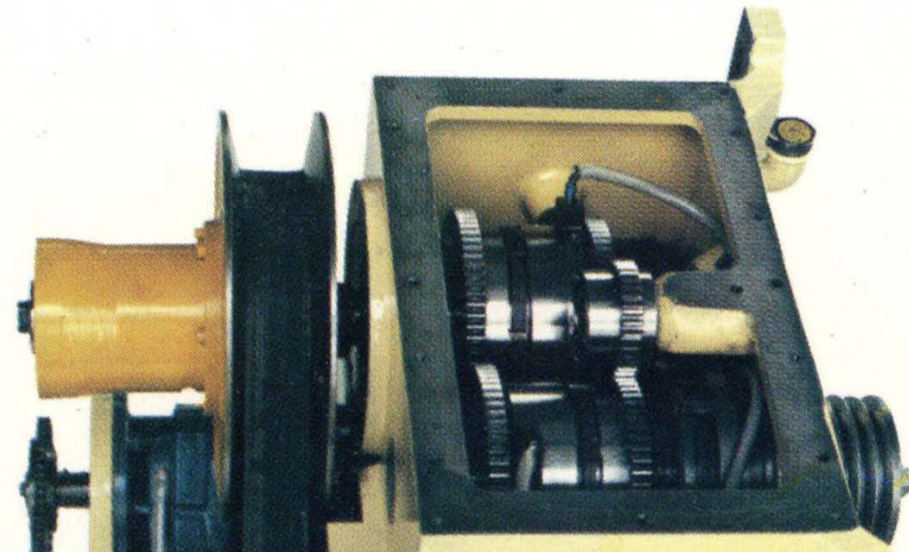

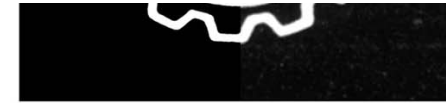
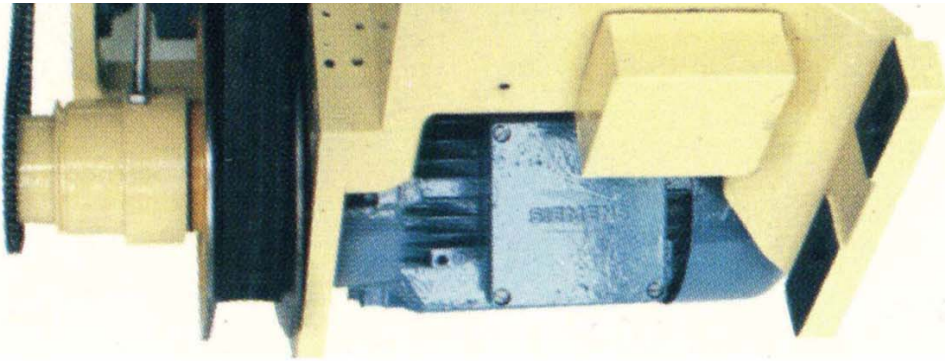

SPEED CONVERTER

It consists of: one driving pulley at mechanical control, one self-adjustable driven pulley and one toothed V-type belt.

The converter drive is controlled directly from the cabinet: one motoreducer controls the driving

pulley that drags in the movement the self-adjustable driven pulley to which is connected by means of the V-belts and determines the speed change.

THE GEAR BOX

The fully-enclosed gear box has a

simple 10-position handwheel. Two others levers provide 30 Whitworth and 30 Metric threads without a gear change. All gears in steel rotate in an oil bath and run on hardened and ground spline shafts.

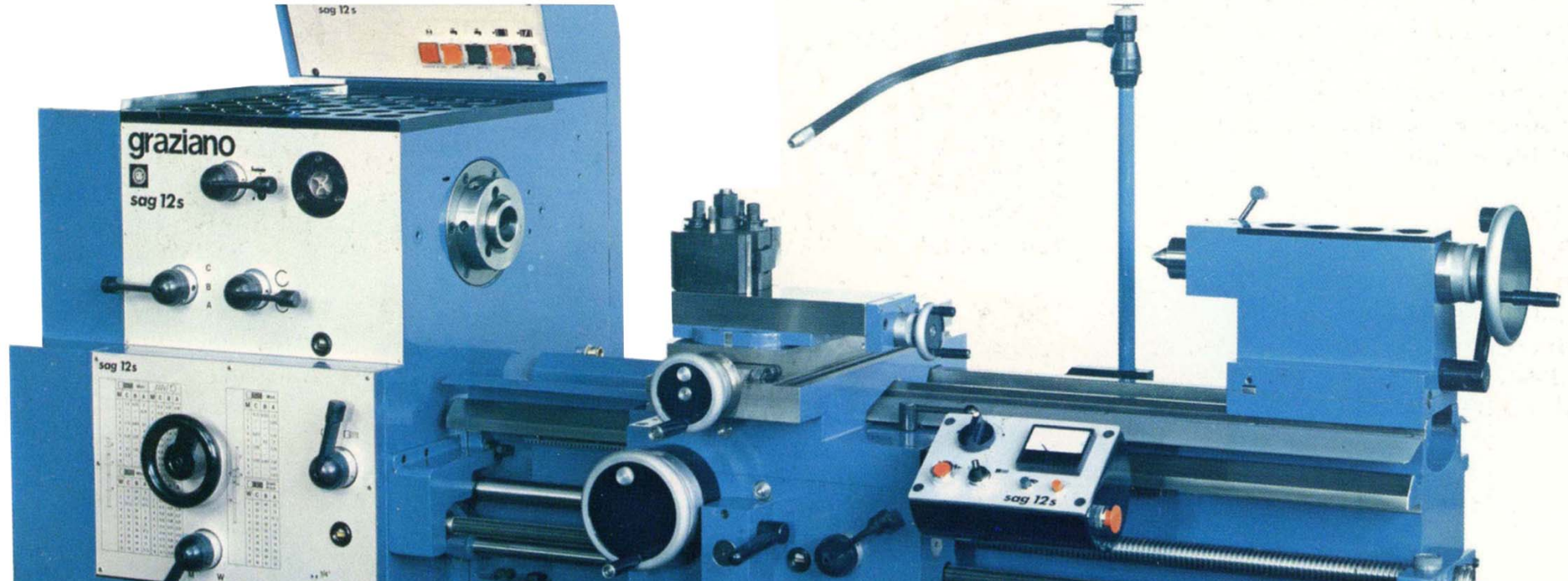

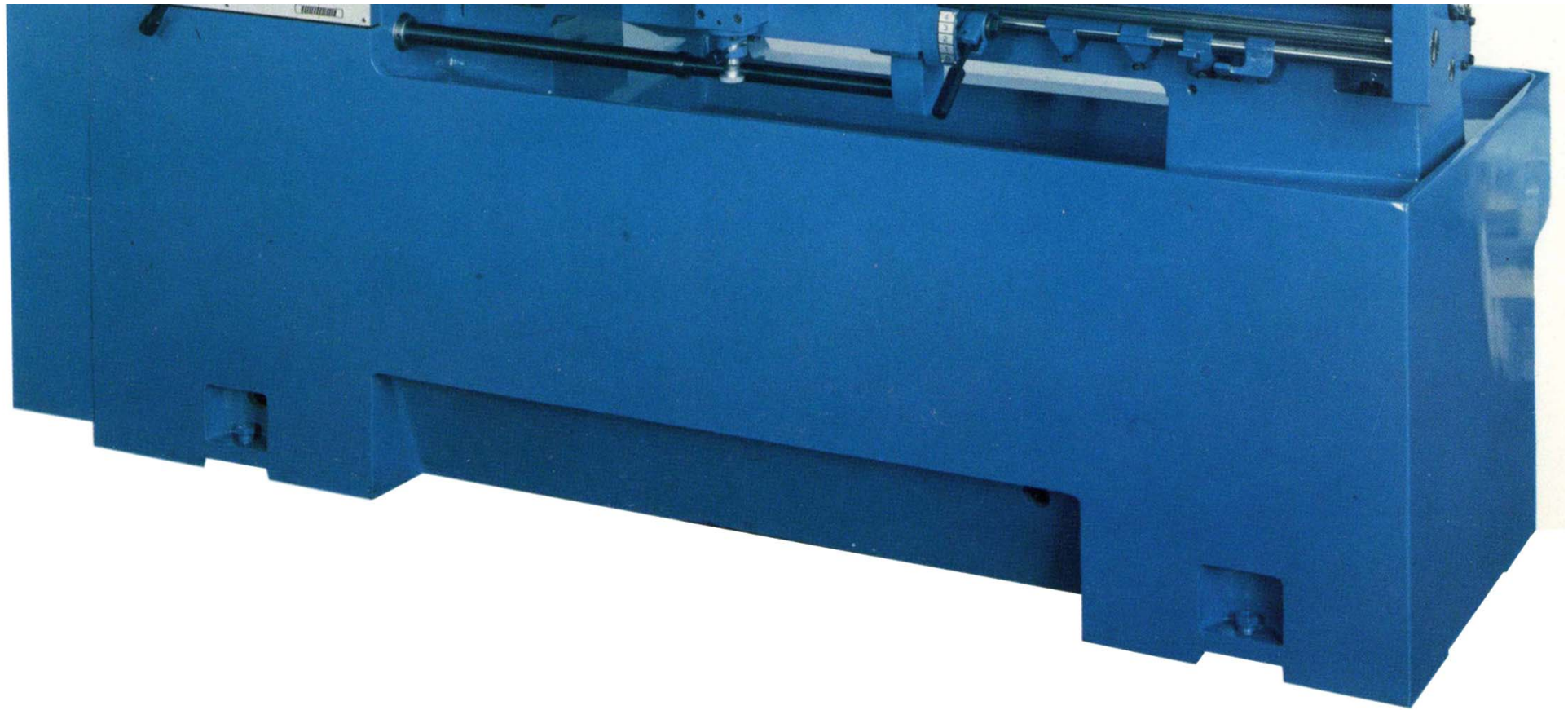

BED AND CARRIAGE

The bed, made of Meehanite and cast iron, maintains the same characteristics of the Sag lathes: carriage ways are lower than the tailstock ways and protected by two steel plates, a wide and deep

THE TAILSTOCK

The rugged tailstock has an hardened sleeve and a quick-acting lock by lever. The tailstock projects well over the ways so that short workpieces can be accommodated without excessive extension of the slide

two steel plates, a wide and deep natural gap produced by the tail-stock stop at a certain distance from the headstock.

The longitudinal slide slides on wide dimensioned ways which insures an uniform and accurate movement. The cross slide and compound are made in steel and fitted with tapered gibs for backlashes. Leadscrews have easy-reading graduate dials.

APRON

The box-shaped apron is totally enclosed with gears and shafts running in an oil bath. All components are lubricated at splash. A clutch device disengages all feeds in case of excessive stress.



extension of the sleeve.

It can be cross adjusted for the machining of taper workpieces. A graduated dial permits the measurement of cut depth.

COOLANT UNIT

The coolant unit includes: the selfpriming electropump, pipes, connections, cock, chip pan and a built-in tank with gauge for coolant.

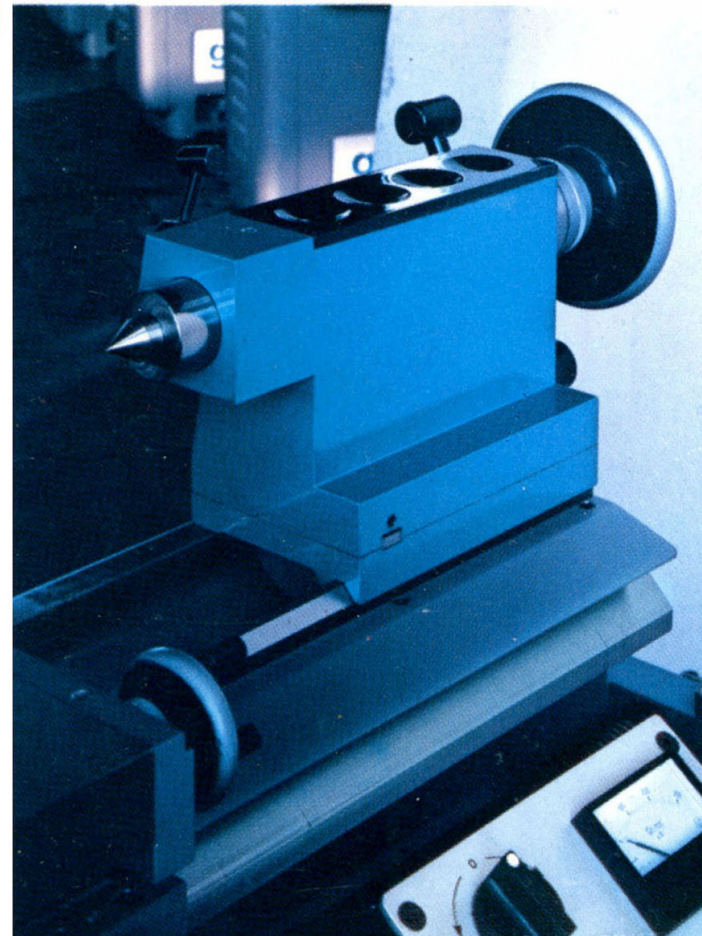

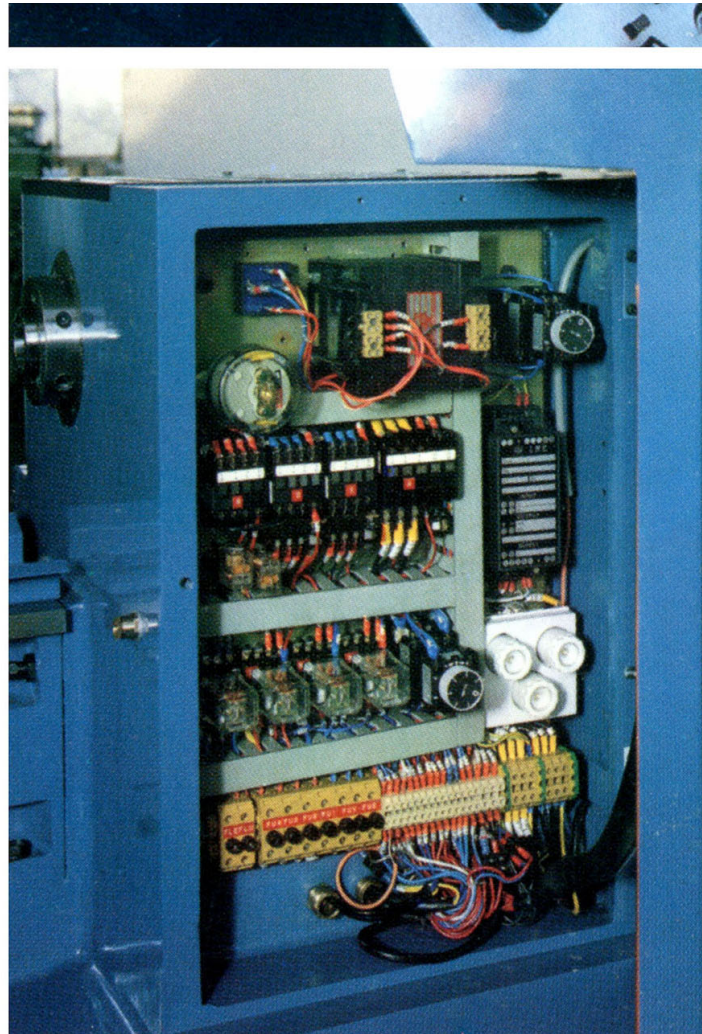
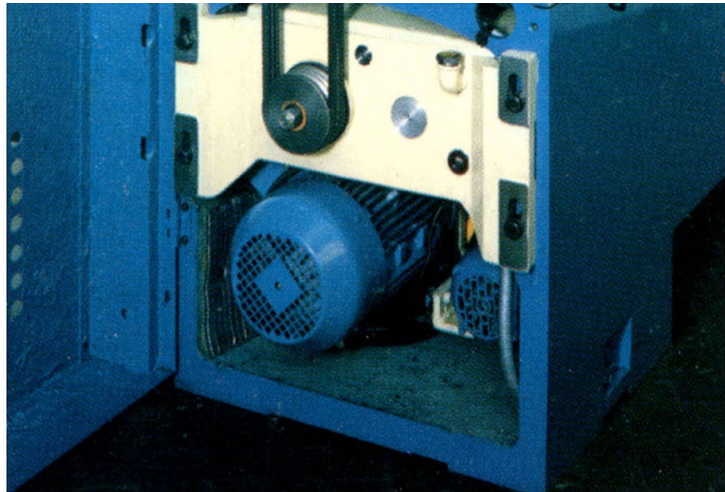

SAG12S

MAIN FEATURES
AND SPECIFICATIONS

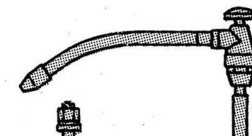
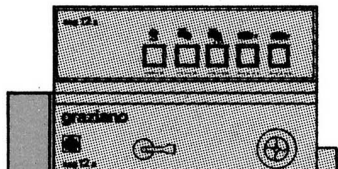
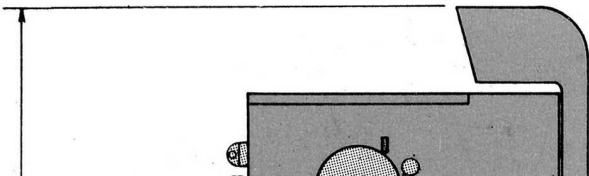

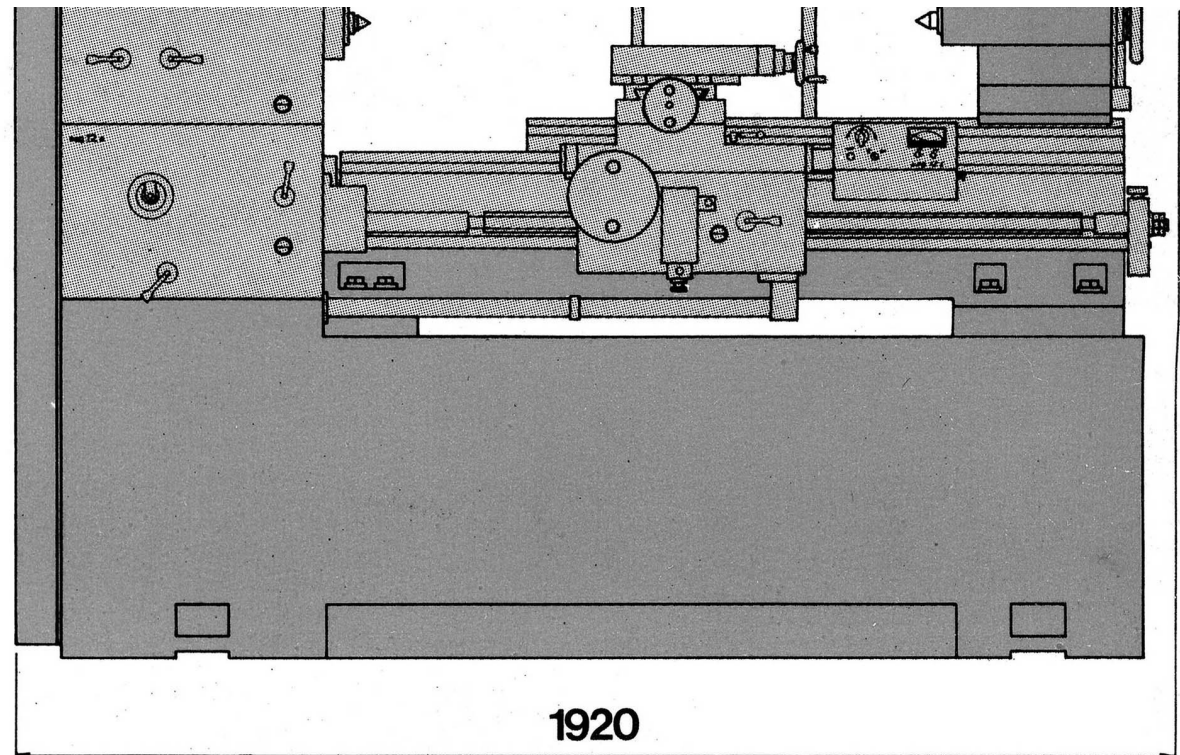
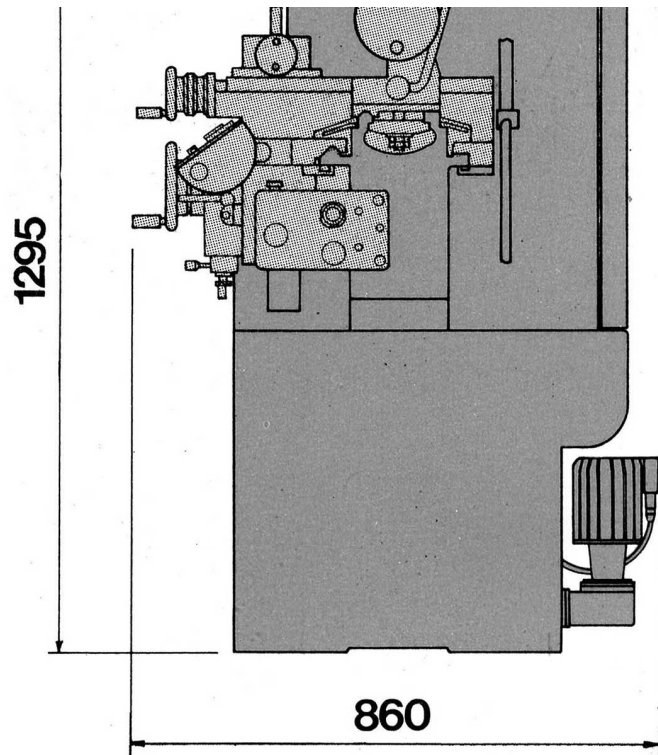

GENERAL FEATURES

Height of centers over bed	mm	153	6"
Distance between centers	mm	800	32"
Swing over carriage	mm	166	6 1/2"
Swing over natural gap	mm	440	17 5/16"
BED			
Width of bed	mm	245	9 5/8"
Length of the natural gap in front of the dog plate	mm	230	9 1/16"
HEADSTOCK			
Spindle bore	mm	41	1 5/8"
Cone Morse	N.	5	
Spindle nose	Cam-Lock	D1-4"	
SPINDLE SPEED			
Two available speed ranges: continuous variation	Rpm	55÷360	55 to 360
		310÷2000	310 to 2000

30 pitch	Pitch	92÷12	92 to 12
30 Modular pitches	Mod.	0.375÷2.875	0.375 to 2.875
Lead screw pitch	TPI	4	4

CROSS SLIDE			
Length	mm	459	18 1/16"
Width	mm	150	5 7/8"
Maximum travel	mm	180	7 1/8"

TOOLPOST SADDLE			
Length	mm	244	9 5/8"
Width	mm	100	3 15/16"
Maximum total travel	mm	110	4 5/16"
Rotation angle	°	360	360
Maximum tool section	mm	20 x 20	3/4"

TAILSTOCK			
Sleeve bore	mm	50	1.968
Max length of sleeve	mm	225	8 7/8"

continuous variation	kpm	80-470	80 to 470
		470÷2600	470 to 2600

FEEDS AND THREADS

60 longitudinal feeds.....	mm	0.05÷0.58	.0019 to .023
60 cross feeds.....	mm	0.02÷0.29	.0009 to .011
30 Whitworth pitches	TPI	46÷6	46 to 6
30 metric pitches	mm	0.75÷5.75	0.75 to 5.75

graziano &c. s.p.a.

15057 Tortona (Italy) - Via Bertarino, 15

Tel. (0131) 812081/2/3/4/5

Telex 210376 Graz i - Telex 210460 Sag cn i

Divisione Controllo Numerico

Via Bertarino, 4/a

Tel. (0131) 811204/5 - 812117

MAX LENGTH OF SLEEVE.....	mm	220	8 11/16"
Maximum sleeve travel	mm	145	5 11/16"
Cone Morse	N.	3	3
Support length on bed.....	mm	222	8 3/4
MOTOR.....	HP	4	4
Approximate weight.....	Kg.	1000	Lbs 2208

310.1100.079







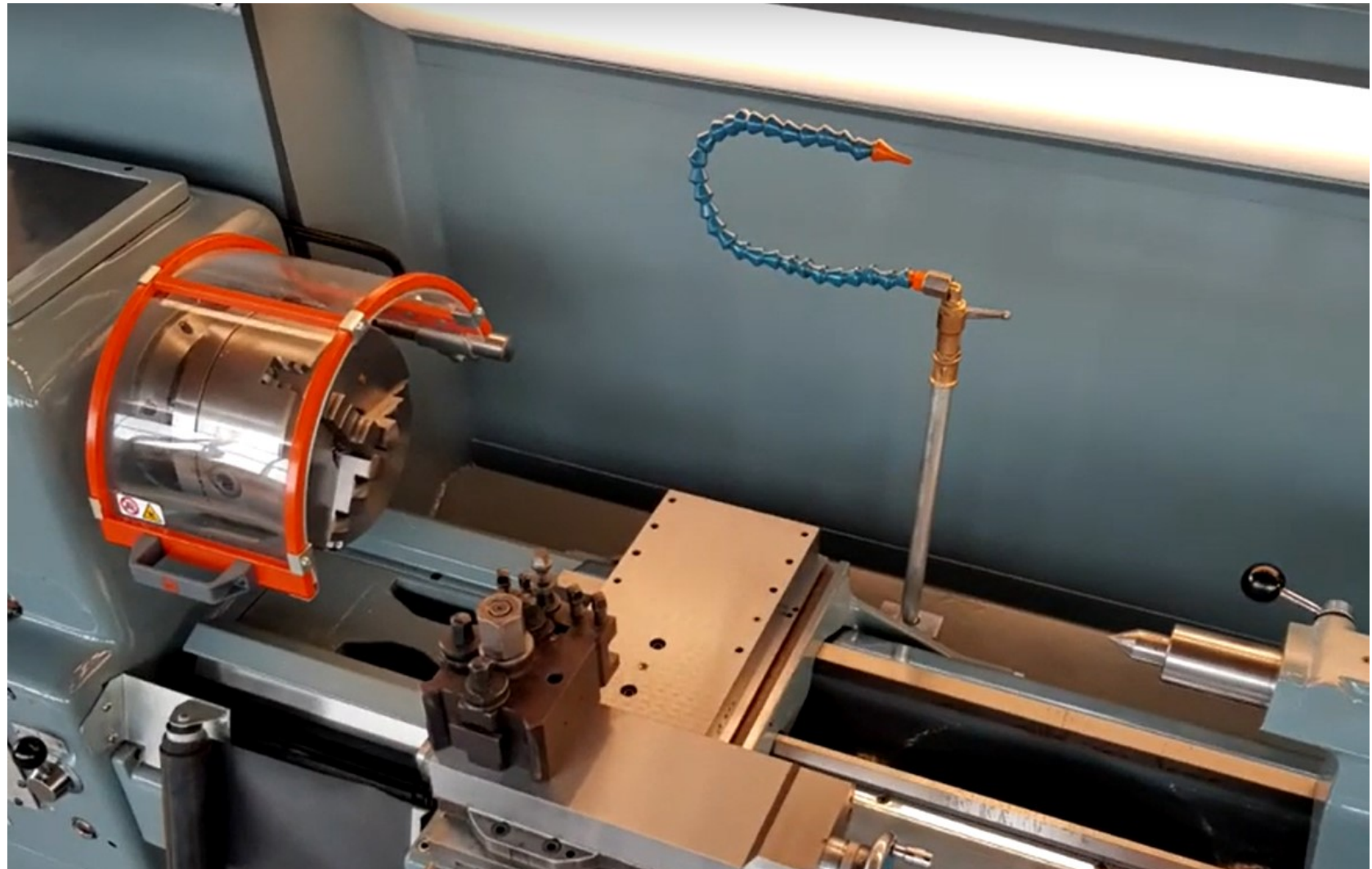

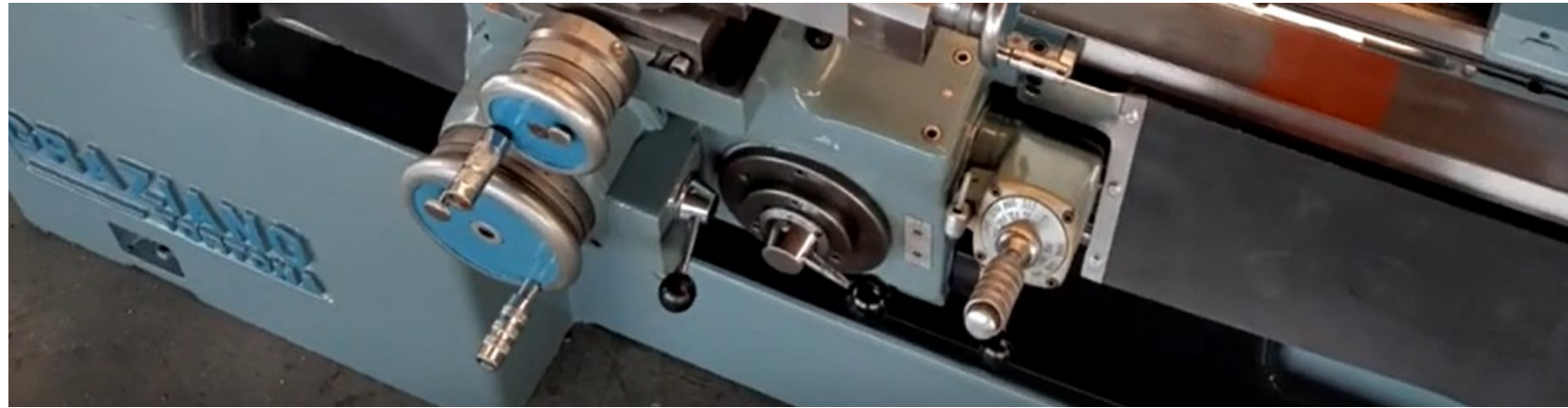

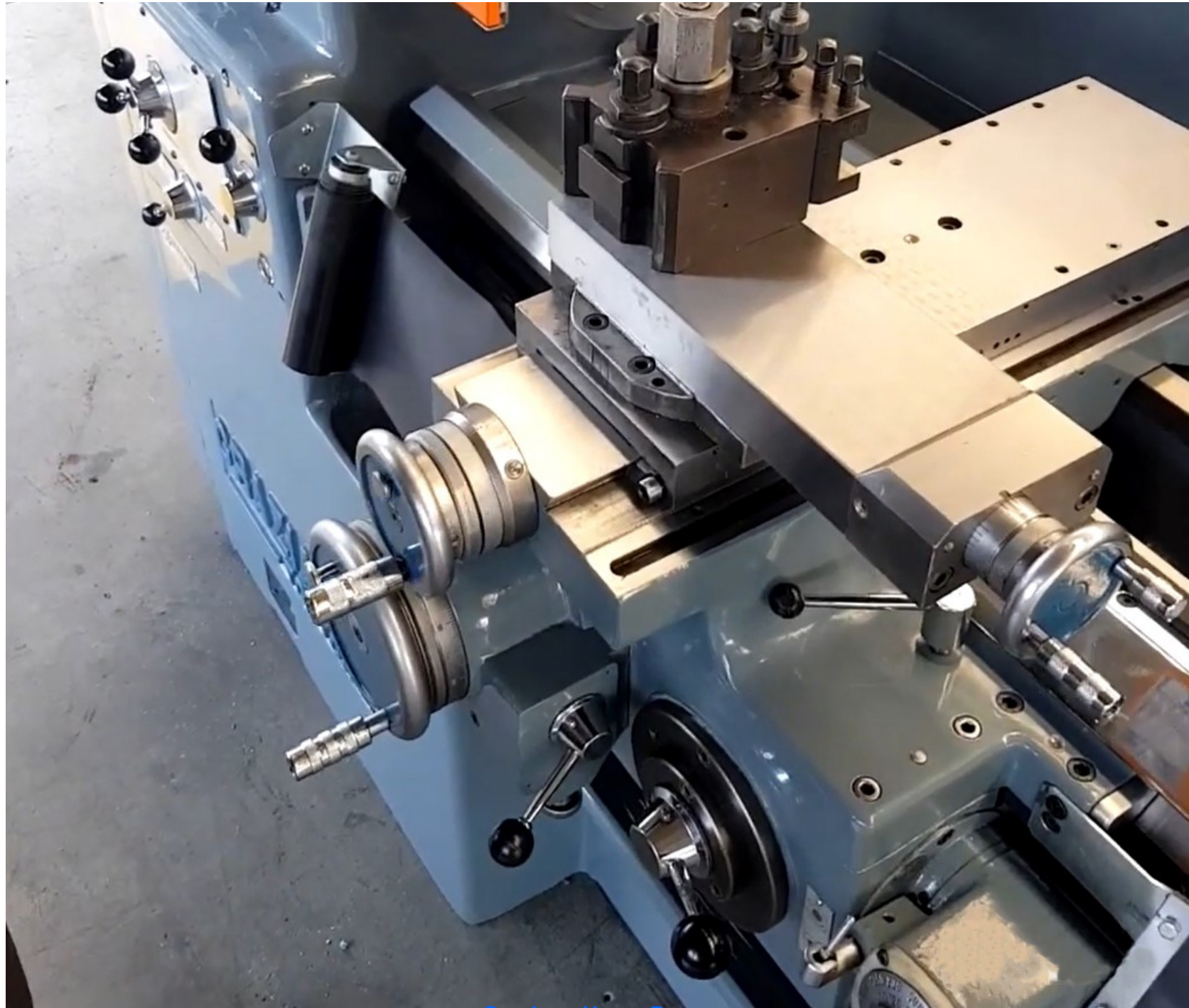

[Graziano Home Page](#)

[Graziano SAG 508, SAG 230, SAG 22 and SAG 20 Lathes](#)

[Graziano SAG 14 & 180 Details](#) [Graziano SAG 22n, 22nr and 22nrf Lathes](#)

[Graziano SAG 17 Lathe](#)

**Instruction, Maintenance & Parts
Manuals for many SAG lathes [are available](#)**

Graziano SAG 12 Lathe - Early and Late

email: tony@lathes.co.uk

[Home](#) [Machine Tool Archive](#) [Machine-tools Sale & Wanted](#)
[Machine Tool Manuals](#) [Catalogues](#) [Belts](#) [Books](#) [Accessories](#)